



FOOD WARMERS: MERCHANDISERS POUCHED PRODUCT, ADVANTAGE™

Model FSAF



BID DESCRIPTION

The Food Server Advantage™ is designed to dispense fudge and caramel from a specialized pouch with 16 mm fitment. Advantage™ units are constructed of a stainless steel enclosure with a brushed (#4) finish, ABS plastic lid and high-temperature molded top. Pump is stainless steel with welded construction. Includes Caramel and Fudge magnetic signs for merchandising. Note: Caramel and Fudge pouches are in limited distribution; contact Server Products for details.

Temperature settings are marked on the thermostat knob. Power is controlled with an ON/OFF rocker switch.

Capacity is (2) 96 oz (1.8 L) pouches with 16 mm fitment. Pump valve features captured stainless steel balls. Maximum stroke yields 1 ounce (30 mL) with gauging collars supplied to reduce yield in 1/8 ounce (3.7 mL) increments.

STANDARD FEATURES

- Closed, sanitary system dispenses from (1) pouch while warming a second pouch to serving temperature
- Outside of pump remains clean
- Evacuation*: 96% fudge, 97% caramel
- Pump design prevents loss of valve balls
- 1 oz (30 mL) maximum portion, now adjustable in 1/8 ounce (3.7 mL) increments — allows for Portion Optimization™
- Magnetic merchandising signs attract attention

ACCESSORY ITEMS

- Cylinder-side cleaning brush 82049
- Spout-side/cast valve cleaning brush 82526

FSAF 85070



ALSO AVAILABLE FOR EXPORT

TWO YEAR WARRANTY

Server Products equipment is backed by a two-year limited warranty against defects in materials and workmanship. For a copy of our complete warranty statement, please refer to server-products.com.

FOOD WARMERS: MERCHANDISERS POUCHED PRODUCT, ADVANTAGE™

Model FSAF

FOOD SERVER ADVANTAGE™

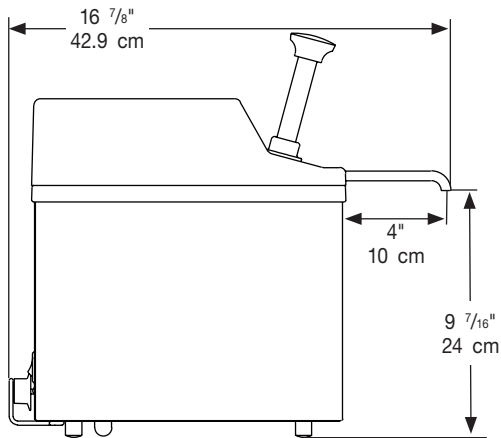
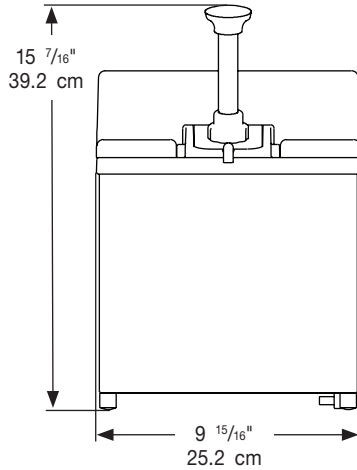

SPECIFICATIONS

Construction	Stainless steel enclosure, ABS plastic lid, and high-temperature molded top. Stainless steel pump with welded construction.		
Certifications	NSF, C UL US		
Capacity	(2) 96 oz (1.8 L) pouches		
Dimensions	<u>Height</u>	<u>Width</u>	<u>Depth</u>
	15 ⁷ / ₁₆ " 39.2 cm	9 ¹⁵ / ₁₆ " 25.2 cm	16 ⁷ / ₈ " 39.4 cm
Electrical	120V, 60Hz, 350W, 2.9A, 72 in (183 cm) cord set NEMA 5-15P, 15A, 125V PLUG 28 lb (12.7 kg)		

FOB RICHFIELD, WISCONSIN 53076

CAD LIBRARY

Individual CAD images can be downloaded from our website. We are also a member of The KCL CADalog with more than 100 other manufacturers. Our complete collection of CAD files can be purchased through Kochman Consultants, Ltd. at kclcad.com.

* Test results on file