



STAINLESS STEEL MOBILE MIXER & EQUIPMENT TABLES



MOBILE
MIXER TABLE



MIXER
EQUIPMENT
TABLE

Drawer Optional

Item #: _____ **Qty #:** _____

Model #: _____

Project #: _____

MOBILE MIXER TABLES

O.A. W x L	Model #	Style	Weight
30" x 30"	MT-MS-300	Stainless Steel	85 lbs.
30" x 36"	MT-MS-303	Stainless Steel	95 lbs.
30" x 30"	MT-MG-300	Galvanized	85 lbs.
30" x 36"	MT-MG-303	Galvanized	95 lbs.

MIXER EQUIPMENT TABLES

O.A. W x L	Model #	Style	Weight
24" x 30"	AG-MP-30	Stainless Steel	65 lbs.

MOBILE MIXER TABLE with Tray Slides

FEATURES:

TOP is furnished with a 2" x 1" square die embossed NO-DRIP countertop offset edge with a 1/2" return on 4 sides.

Cross Bracing welded to front legs. Cross Bracing on sides is bolted to legs and requires assembly.

Pan Rack Slides sized for (6) 18" x 26" pans.

MATERIAL:

MT-MS SERIES - Stainless Steel Base

TOP is 14 gauge stainless steel type "304" series with galvanized understructure.

LEGS are 1 5/8" diameter, stainless steel. Gussets are stainless steel. (4) 5" swivel casters with rubber wheels. (2) with brakes

PAN RACK is aluminum with 2" tray slide spacing.

MT-MG SERIES - Galvanized Base

TOP is 14 gauge stainless steel type "304" series with galvanized understructure.

LEGS are 1 5/8" diameter, galvanized steel. Gussets are galvanized steel.

(4) 5" swivel casters with rubber tires. (2) with brakes.

PAN RACK is aluminum with 2" tray slide spacing.

MIXER EQUIPMENT TABLE

FEATURES:

TOP is furnished with a 2" x 1" square die embossed NO-DRIP countertop offset edge with a 1/2" return on 4 sides.

Aluminum die cast "leg to shelf" clamp secures shelf to leg eliminating unsightly nuts and bolts. Undersshelf is adjustable.

Pre-engineered angle adapters insure ease of future drawer installation (Mixer Equipment Table Only).

Stainless steel handle and two rubber bumpers secured to table top.

MATERIAL:

AG-MP-30

TOP is heavy gauge stainless steel type "430" series with galvanized understructure.

UNDERSHELF is galvanized steel.

LEGS are 1 5/8" dia. tubular galvanized steel with galvanized steel gussets and (2) 1" adjustable plastic bullet feet.

(2) 5" swivel casters with brakes supplied.

CONSTRUCTION:

Roll formed embossed galvanized hat channels are secured to top by means of structural adhesive and weld studs.

Gussets welded to support hat sections.

All TIG welded. Exposed weld areas finished to match adjacent surfaces.

Entire Top is mechanically polished to a satin finish and is sound deadened.



Customer Service Available To Assist You **1-800-645-3166** 8:30 am - 8:00 pm E.S.T.

Email Orders To: customer@advancetabco.com. For Smart Fabrication™ Quotes, Email To: smartfab@advancetabco.com or Fax To: 631-586-2933

NEW YORK
Fax: (631) 242-6900

GEORGIA
Fax: (770) 775-5625

TEXAS
Fax: (972) 932-4795

NEVADA
Fax: (775) 972-1578

DETAILS and SPECIFICATIONS

TOL ± .500"

ALL DIMENSIONS ARE TYPICAL

MOBILE MIXER TABLE with Tray Slides

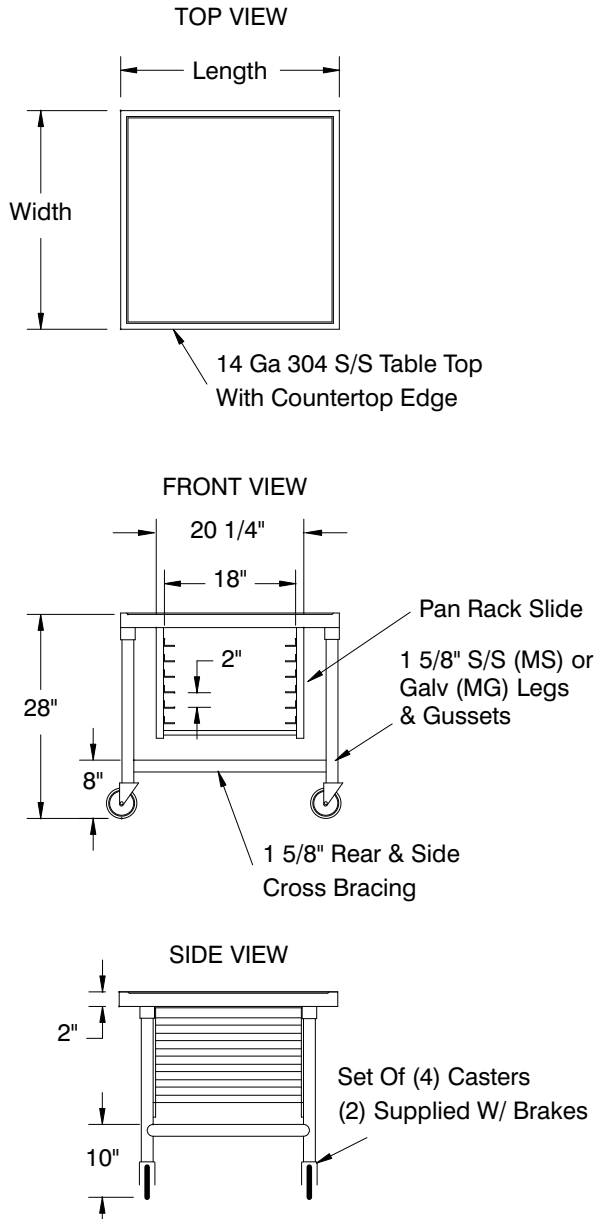

MIXER EQUIPMENT TABLE

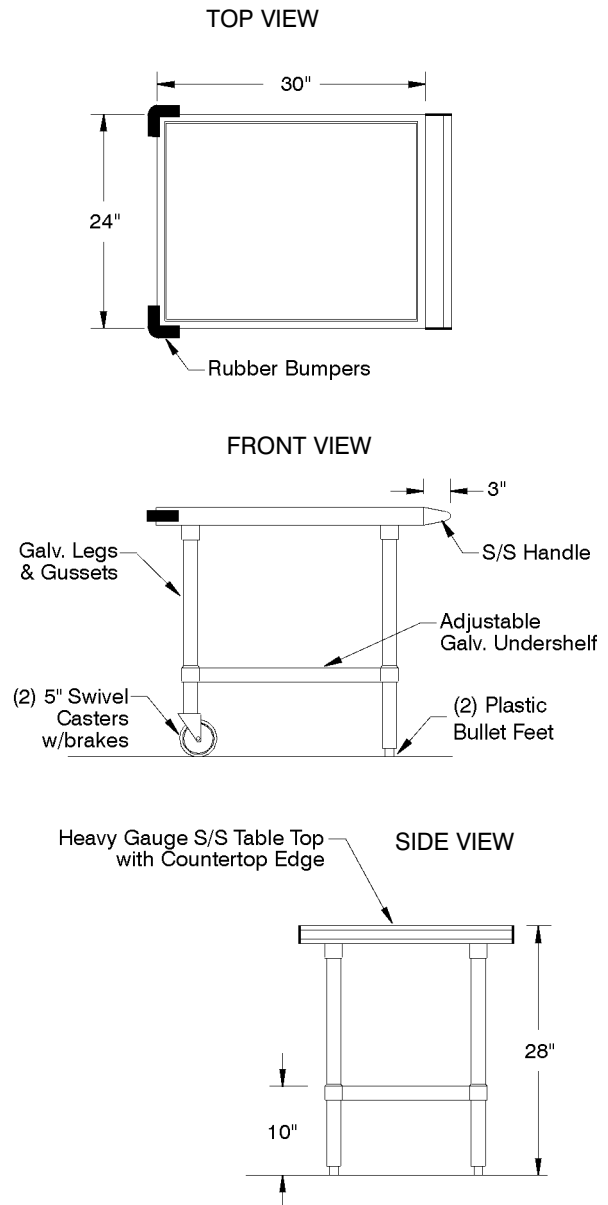

Countertop Edge Detail

