



# Insulated Hot Food Wells

## Bottom Mount Series

Models:  BM-80  BM-80D  BM-80-UL  BM-80D-UL ("D" designates drain)

PRODUCT:

QUANTITY:

ITEM #:

### Designed Smart

#### Greatest Selection of Hot Food Wells!

- Heavy-duty bottom mount, insulated rectangular drop-in hot food well is designed for installation in metal countertop.
- Available with Round Corners or Square Corner (add a "C" to model number) designs.
- Units available in a UL recognized component construction with open wires and increase-decrease plate or complete UL listed construction including electrical conduit, bezel and control box.
- Available in a variety of wattage power to accommodate your needs, whether it is for High Performance, Fast Recovery power or Energy Efficient, Lower wattage (750 watts) power.
- Available with Welded Drain Design or no drain.

#### Most Effective Heat System!

- All Bottom Mounted Food Wells are heated by tubular calrod heat element shaped in serpentine fashion for even heat distribution to pan base.
- Element is mounted under well and secured by an aluminized reflector shield for maximum efficiency.
- Thermostatically controlled for fast heat recovery.

### Built Solid

- Constructed of deep-drawn 20 ga. type 304 stainless steel.
- Units with drain are provided with stainless steel 1/2 NPT drain welded to bottom of pan and provided with removable screen.
- Entire heat assembly covered with inspection housing with layer of 1 1/2" thick compressed fiberglass insulation.

#### Reliability backed by APW Wyott's Warranty

- All APW Wyott food wells are backed by a 1-year parts and labor warranty, including on-site service calls within 50 miles of authorized service technicians.
- Certified by the following agencies:

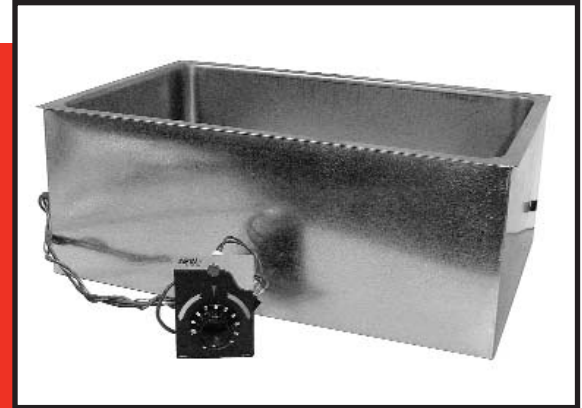

Insulated Bottom Mount Hot Food Well BM-80

### APW Wyott Design Features

- 20 ga. deep-drawn stainless steel well pans.
- Available with or without drain.
- Unit may be used wet or dry (wet use offers best results).
- Easy access to heating elements.
- Thermostatic control with 36" capillary (effective length 26").
- Large indicating pilot light.
- Multiple units can be installed in same table or counter.
- Multiple wattages and voltage choices

### Options

- Thermostat with 72" capillary (effective length 62")
- Recessed bezel (56360)
- Drain kit (56420)
- Lever operated shut off valve (56360)
- Infinite Controls
- Square corners - BM-80C

See reverse side for product specifications.



APW Wyott Foodservice Equipment Company · 729 Third Ave., Dallas, TX 75226  
(800) 527-2100 · (214) 421-7366 · Fax (214) 565-0976 · www.apwwyott.com · info@apwwyott.com

Rev. 5/22/2005



# Insulated Hot Food Wells Bottom Mount Series

Models:  BM-80  BM-80D  BM-80-UL  BM-80D-UL ("D" designates drain)

PRODUCT:

QUANTITY:

ITEM #:

## Bottom Mount Hot Food Wells

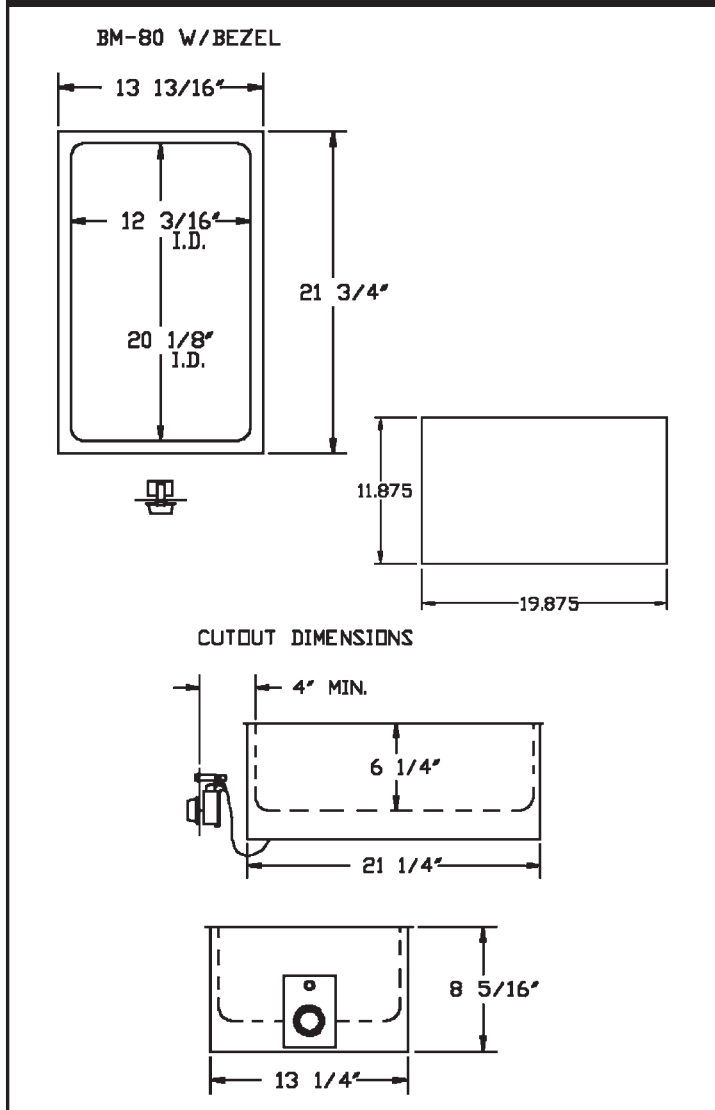

## PRODUCT SPECIFICATIONS

### Construction:

Well is constructed of deep-drawn 20 ga. type 304 stainless steel, with 28 ga., fully insulated aluminized steel outer housing. Units shipped with drain are provided with stainless steel 1/2" NPT drain welded to bottom of pan provided with removable screen. Unit is heated by a tubular calrod heat element shaped in serpentine fashion for even heat distribution to pan base. Element is mounted under well and secured by aluminized reflector shield for maximum efficiency. Top edge of unit has a 13/16" flange. Recommended flange turndown 3/4". BM-80 Round Corner versions are made with a 1" radiused. Thermostatic control has 36" capillary (effective length 26")

### Electrical Specifications:

120V, 750W, 6.25 Amps  
 120V, 1200W, 10 Amps  
 208V, 1600W, 7.7 Amps  
 208/240V, 1200/1600W, 5.8/6.7 Amps  
 208/240/277V, 900/1200/1600W, 4.3/5.0/5.8 Amps

### Overall Dimensions:

Outside: 8 5/16"H x 13 13/16"W x 21 3/4"L  
 (21.1cm x 35.1cm x 55.2cm)

Inside: 6 1/4"H x 12 3/16"W x 20 1/8"L  
 (15.9cm x 30.9cm x 51.1cm)

Cutout: 11 7/8"W x 19 7/8"L  
 (30.2cm x 50.5cm)

UL Models: Control size: 5 15/16"W x 6 7/16"H  
 Control cutout: 5 3/4"W x 6 1/4"H  
 If UL kit added, 6" clearance necessary for thermostat box.

### Shipping Information:

Weight: 20 lbs. (9.1kg), UL models: 24 lbs. (10.9kg)  
 Freight Class: 92 1/2  
 FOB: Dallas, TX 75226

\*APW Wyott reserves the right to modify specifications or discontinue models without incurring obligation.



APW Wyott Foodservice Equipment Company · 729 Third Ave., Dallas, TX 75226  
 (800) 527-2100 · (214) 421-7366 · Fax (214) 565-0976 · www.apwwyott.com · info@apwwyott.com

Rev. 5/22/2005  
 # 1401