

PRODUCT:

QUANTITY:

ITEM #:

Designed Smart

Maximum Overhead Heat for Warming Areas

- Delivers over 22% more heat to your prepared food than competitive models
- Unique heating system provides the highest wattage in the category. High watt version has 15% more power than competition.
- Aluminized steel reflectors behind heating elements radiate more heat toward food.

Easy to Install & Customize to Current Systems

- All units come standard with sturdy stainless steel mounting brackets.
- A wide option of lengths and mounting accessories let you customize the overhead warming system that is perfect for your operation. (Stands to hold up to 48")
 - T Leg Stands
 - Tubular post mount stand
 - Chain Suspension
- Extra electrical conduit knockout locations allow flexibility in installation
- Available with either an infinite or toggle control that can be supplied within the unit or in a "remote" control box. (Remote is recommended). Installer provides wiring between "remote" control box and unit. (Remote is recommended).

Easy to Use

- Pilot lights are standard features that keep your employees aware of the unit's operations.

Built Solid

Most Durable Overhead Warmer in the industry!

- Stainless steel construction resists corrosion, is easy to clean, and presents an attractive appearance
- Control components are insulated in a ventilated box construction for increased reliability and longevity
- APW Wyott overhead warming equipment is backed by a 2-year warranty on heating elements and a 1-year parts and labor warranty



Overhead Warmer Accessories

- Remote Control Box (shown below) Pilot light switch box, control and cover with single, dual, or triple controls 1lbs (.5kg)
- Tubular Stand Kit (76180) 1 pair legs for permanent mounting (48" or smaller units only) 5lbs (2.3kg)
- Portable Leg Kit (76200) 1 pair legs and accessories for freestanding operation 5lbs (2.3kg)
- Cord & Plug set (75906) For portability, includes adapter bushing. (120V units, 48" and smaller only) 7lbs (3kg)
- Chain Supports (75901) For overhead suspension without flush mount 1lb (.5kg)

Certified by the following agencies:



Remote Control Box



PRODUCT:

QUANTITY:

ITEM #:

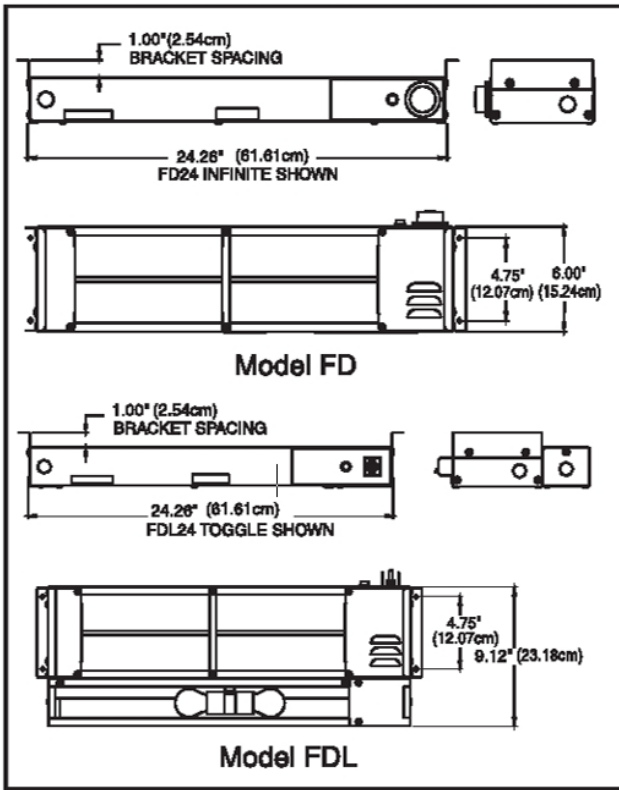

Overall Dimensions:

FDD and FDDL models are 15" wide

FD-18 & FDL-18: 18.26" (46.3 cm)	FD-54 & FL-54: 54.26" (137.8 cm)
FD-24 & FDL-24: 24.26" (61.6 cm)	FD-60 & FDL-60: 60.26" (153.0 cm)
FD-30 & FDL-30: 30.26" (76.8 cm)	FD-66 & FDL-66: 66.26" (168.2 cm)
FD-36 & FDL-36: 36.26" (92.0 cm)	FD-72 & FDL-72: 72.26" (183.5 cm)
FD-42 & FDL-42: 42.26" (107.3 cm)	
FD-48 & FDL-48: 48.26" (122.5 cm)	

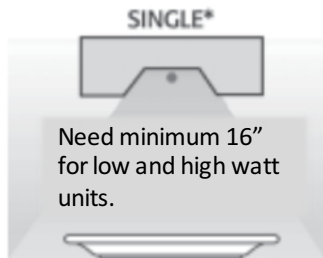

Product Specifications

Construction:

Stainless steel housing and aluminized steel radiant reflector, metal-sheathed heating element and angle brackets "L" indicated built-on illumination box, which uses incandescent safety lights

Electrical Information:

Specify voltage and wattage; also, infinite control or toggle switch (remote control units that are operated by optional remote control kits). Remote control units use separate/optional remote control kits to allow for maximum installation flexibility. Up to 3 remote units can be controlled by a single triple remote control kit. Sizes above 60" are only available in 208/240V versions.

FOB: Allen, TX 75013

Sizes 60" and above ship LTL only

Freight Class: 100

	Size	Single		Single Lighted			
		Watts	lbs	kg	Watts	lbs	kg
High Wattage	18"	400	7	3.2	480	7	3.2
	24"	575	7	3.2	655	8	3.6
	30"	760	8	3.6	840	9	4.1
	36"	920	9	4.1	1080	11	5
	42"	1100	12	5.4	1260	12	5.4
	48"	1265	12	5.4	1425	12	5.4
	54"	1425	13	5.9	1585	14	6.4
	60"	1610	14	6.4	1850	15	6.8
Low Wattage	66"	1800 (208/240v)	16	7.3	2040 (208/240v)	17	7.7
	72"	1980 (208/240v)	17	7.7	2220 (208/240v)	18	8.2
	18"	250	5	2.3	330	6	2.7
	24"	350	7	3.2	430	8	3.6
	30"	450	8	3.6	530	9	4.1
	36"	575	9	4.1	735	11	5
	42"	675	11	5	835	12	5.4
	48"	800	12	5.4	960	12	5.4
	54"	925	13	5.9	1085	14	6.4
	60"	1050	14	6.4	1290	15	6.8
	66"	1160 (240v)	16	7.3	1400 (240v)	17	7.7
	72"	1275 (208/240v)	17	7.7	1515 (208/240v)	18	8.2

APW Wyott reserves the right to modify specifications or discontinue models without incurring obligation