

PRODUCT:

QUANTITY:

Models  GCB-18i  GCB-24i  GCB-36i  GCB-48i  
ITEM:

## Designed Smart

### Increased Performance

- Increased performance in cooking
- One of the highest BTU ratings in its cooking class
- Reduces amount of labor time to cook a ¼ pound hamburger by 20%
- Fast start-up and recovery to prime cooking temperatures.
- Versatile grate system can be adjusted in height to give maximum control
- Special high temperature stainless steel radiants provides even heat across the cooking area
- Openings in the front allow the pilot light to be easily lit and adjusted without removing the front panel
- Infinite adjustable gas valves turn 180 degrees, giving the operator ultimate control

### Safety Features

- Bull-nose front extension protects employees from burns

### Saves Time and Clean-up Labor Cost

- Maintenance is easier with bottom-mount grease collection pan and removable top grates
- Self-cleaning radiants
- Field convertible and adjustable gas regulator

## APW Wyott Design Features

- ¾" (1.9cm) cast iron "steak char" grate
- Fish Grate (#3102202) and flat griddle play overlay (#21813095)
- Special high temperature stainless steel radiants
- Field convertible and adjustable gas regulator
- 3" (7.6) stainless steel backsplash; sloped side splashers
- Front access panels for easy adjustment
- Extended bull-nose front
- Heavy-duty 4" (10.2cm) heat-resistant, adjustable legs.
- Viewable standing pilot. Safety pilot available
- Pilot can be lit without removing front panel
- Gas connections use ¾" NPT pipe
- 4" x 1" (10.2 cm x 2.5 cm) grease chute drains into grease drawer
- Stainless steel grease collector drawer



Model GCB-24i Gas Radiant CharBroiler

## Options & Accessories

- High altitude versions are available (contact factory)
- Fish grate only versions available
- Safety pilot
- Griddle Plate

## Reliability backed by APW Wyott's Warranty

All APW Wyott Heavy Duty Cookline Equipment is backed by our 2-year parts and labor warranty .

•Certified by the following agencies:



\*Warranty does not include rock grates, cooking grates, burners shields or fireboxes.

See reverse side for product specifications.

PRODUCT:

QUANTITY:

Models  GCB-18i  GCB-24i  GCB-36i  GCB-48i  
ITEM:

GCB-24i

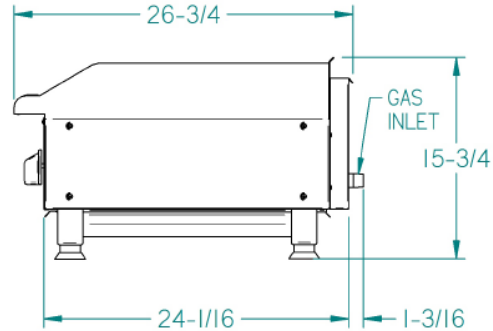
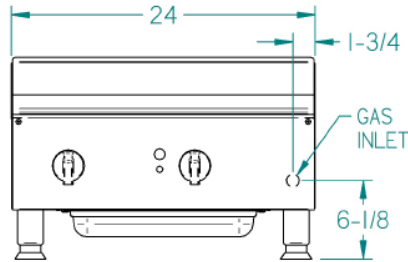

## PRODUCT SPECIFICATION

### Construction:

Stainless steel top skirt, grease trough, grease collector drawer, and front panel. Stainless steel radiant. Aluminized steel sides and back panel. 4" adjustable legs. Welded construction. Field convertible and adjustable gas regulator.

### Gas Specifications:

- GCB-18i: 1 "S" burner, total 60,000 BTU/hr. One manual control. (Propane is 54,300 BTU/hr.)
- GCB-24i: 2 "U" burners, 40,000 BTU/hr. each. Total 80,000 BTU/Hr. input. Two manual high-low controls. (Propane is 72,500 BTU/hr.)
- GCB-36i: 3 "U" burners, 40,000 BTU/hr. each. Total 120,000 BTU/Hr. input. Two manual high-low controls. (Propane is 108,750 BTU/hr.)
- GCB-48i: 4 "U" burners, 40,000 BTU/hr. each. Total 160,000 BTU/Hr. input. Two manual high-low controls. (Propane is 145,000 BTU/hr.)

### Cooking Surface:

- GCB-18i: 17 1/2" D x 17 1/8"D
- GCB-24i: 23 1/2" D x 17 1/8"D
- GCB-36i: 35 1/2" D x 17 1/8"D
- GCB-48i: 47 1/2" D x 17 1/8"D

### Overall Dimensions:

- GCB-18i: 15 3/4" H x 18" W x 26 3/4"D
- GCB-24i: 15 3/4" H x 24" W x 26 3/4"D
- GCB-36i: 15 3/4" H x 36" W x 26 3/4"D
- GCB-48i: 15 3/4" H x 48" W x 26 3/4"D

**\*NOTE: Regulator and pipe add 4 1/4" to the rear of the unit.**

### Shipping:

- GCB18i: 96 lbs (43.5kg)
- GCB24i: 122 lbs (55.3kg)
- GCB-36i: 173 lbs (78.5kg)
- GCB-48i: 226lbs (102.5kg)

**Freight Class: 70**

**FOB: Allen, TX 75013**

\*APW Wyott reserves the right to modify specifications or discontinue models without incurring obligation.