



# Champion Gas Hot Plate Stepped Series

Models  GHPS-2i  GHPS-4i  GHPS-6i

PRODUCT:

QUANTITY:

ITEM:

## Designed Smart

### Increased Performance

- Champion high output gas burners generate 28,000 BTU's per burner
- Reduces amount of labor time to boil water by 50%
- Fast start-up to prime cooking temperatures
- Openings in the front allow the pilot light to be easily lit and adjusted without removing the front panel
- Thick, stainless steel construction on front panel and top skirt protects against kitchen "wear and tear" and rust
- Thick cast iron grates stand up to years of high output use
- Welded construction
- Curved bull-nose front extension protects employees from burns

### Saves Time and Clean-up Labor Cost

- Maintenance is easier with bottom-mount grease collection pan and removable top grates
- Self-cleaning radiants
- Field convertible gas regulator

## APW Wyott Design Features

- Heavy-duty stainless steel and aluminized steel construction
- 28,000 BTU/hr per cast iron burner
- Smooth action, infinitely adjustable gas valves turn 180 degrees, giving the operator ultimate control
- Field convertible gas regulator
- Removable cast-iron grate
- Stainless steel collection pans
- Adjustable viewable pilot
- 4" (10.2cm) heat-resistant, adjustable legs
- Front or top-serving

\*Warranty does not include cooking grates or fireboxes.



Model GHPS-6i Standard Gas Hot Plate

## Options & Accessories

- WOK Ring Accessory – Part # 21815507
- High altitude versions available (contact factory)

## Reliability backed by APW Wyott's Warranty

All APW Wyott Heavy Duty Cookline Equipment is backed by a 2-year limited warranty and a 2-year on-site labor warrant. \*

•Certified by the following agencies:



See reverse side for product specifications.



APW Wyott Foodservice Equipment Company \* 1307 N. Watters Rd Suite 180, Allen TX 75013  
(800) 527-2100 \* (972) 908-6100 \* Fax (214) 565-0976 \* [www.apwwyott.com](http://www.apwwyott.com)

Rev091616cp

PRODUCT:

QUANTITY:

ITEM:

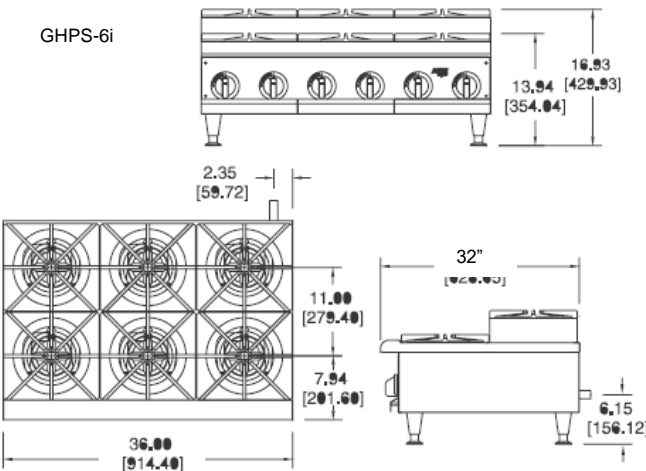
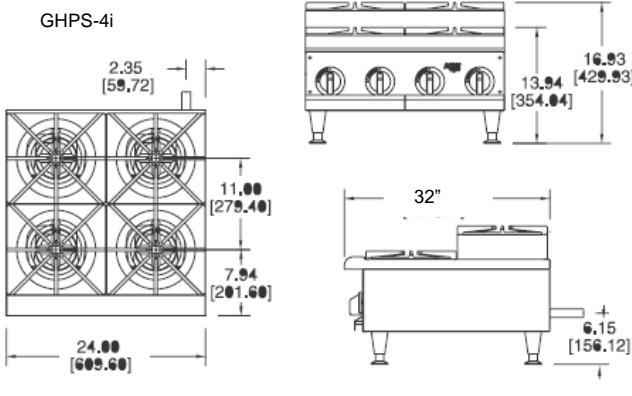
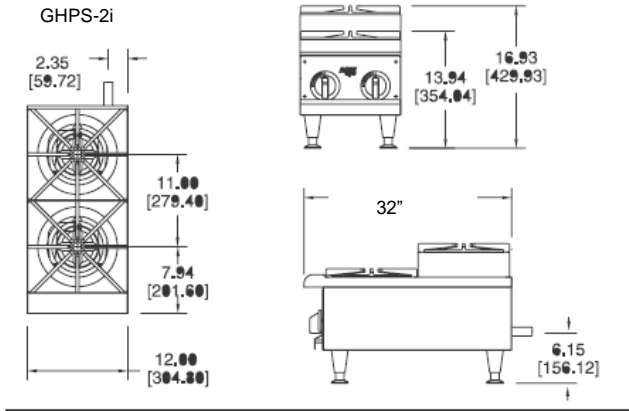

## PRODUCT SPECIFICATIONS

### CONSTRUCTION:

Stainless steel top skirt, crumb tray and front panel. Aluminized steel sides and back panel. Welded construction. Field convertible gas regulator. 4" adjustable legs.

### Gas Specifications:

- GHPS-2i: 2 burners, 28,000 BTU/Hr. each, total 56,000 BTU/Hr. input 2 manual infinitely adjustable controls (Propane is 56,000 BTU/Hr.)
- GHPS-4i: 4 burners, 28,000 BTU/Hr. each, total 112,000 BTU/Hr. input 4 manual infinitely adjustable controls (Propane is 112,000 BTU/Hr.)
- GHPS-6i: 6 burners, 28,000 BTU/Hr. each, total 168,000 BTU/Hr. input 6 manual infinitely adjustable controls (Propane is 168,000 BTU/Hr.)

### Overall Dimensions:

- GHPS-2i: 16 3/4"H x 12"W x 32"D (42.5cm x 30.5cm x 63cm)
- GHPS-4i: 16 3/4"H x 24"W x 32"D (42.5cm x 61cm x 63cm)
- GHPS-6i: 16 3/4"H x 36"W x 32"D (42.5cm x 91.4cm x 63cm)

NOTE: Regulator and pipe add 1 1/4" to the rear of the unit.

### Shipping:

- GHPS-2i: 82 lbs (37 kg)  
 GHPS-4i: 146 lbs (66 kg)  
 GHPS-6i: 216 lbs (98 kg)

Freight Class: 70  
 FOB: Allen, TX 75013

\*APW Wyott reserves the right to modify specifications or discontinue models without incurring obligation.