



Slimline Insulated Multiple Hot Food Well

Models: HFWS-2 HFWS-3 HFWS-4 ("D" after model # designates drain)

PRODUCT:

QUANTITY:

ITEM #:

Bid Specifications

Heavy-duty Top mount insulated Rectangular Drop-In Food The Slim line Top Mount Food well is designed for installation in metal or wood countertop. The well is designed to accommodate standard size steam table pans. The well is constructed of deep drawn 20 ga. Type 304 stainless steel above countertop with 20 ga. aluminized outer housing with sides bottom fully insulated. Units shipped with drain are provided with stainless steel 1/2" NPT drain welded to bottom of pan provided with removable screen. The well is heated by tubular heating element shaped in serpentine fashion for even heat distribution to pan base. The element is mounted under well and secured by aluminized deflector, shield for maximum efficiency. The unit is standard with APW Wyott EZ Locks on all four exterior sides for easy installation. The units feature complete UL construction including electrical conduit, bezel and control box.



Top Mount Hot Food Well

Standard Features

- 20 ga. Deep-drawn stainless steel well pans
- Factory assembled 3/4 manifold drains- screens provided
- Units may be used WET or DRY (Wet use offers best results)
- Easy access to heating elements
- Compact housing- overall depth 8-11/16" and 11-1/2" over drain manifold
- Large indicating pilot light
- Multiple units can be installed in same table or counter
- Simplified construction reduces installation time and significantly reduces on-site electrical and plumbing cost.
- Unitized electrical wiring for single power hookup
- Individual infinite controls

Reliability Backed by APW Wyott's Warranty

- Backed by a 1 year parts & labor warranty.
- Food Wells are Certified by the following agencies:



SANITATION

HFWS-6 not CSA approved

See reverse side for product specifications.



APW Wyott Foodservice Equipment Company · 729 Third Ave., Dallas, TX 75226
(800) 527-2100 · (214) 421-7366 · Fax (214) 565-0976 · www.apwwyott.com · info@apwwyott.com

Rev. 5/01/2008



limline Insulated Multiple Hot Food Well

Models: HFWS-2 HFWS-3 HFWS-4 ("D" after model # designates drain)

PRODUCT: _____ QUANTITY: _____ ITEM #: _____

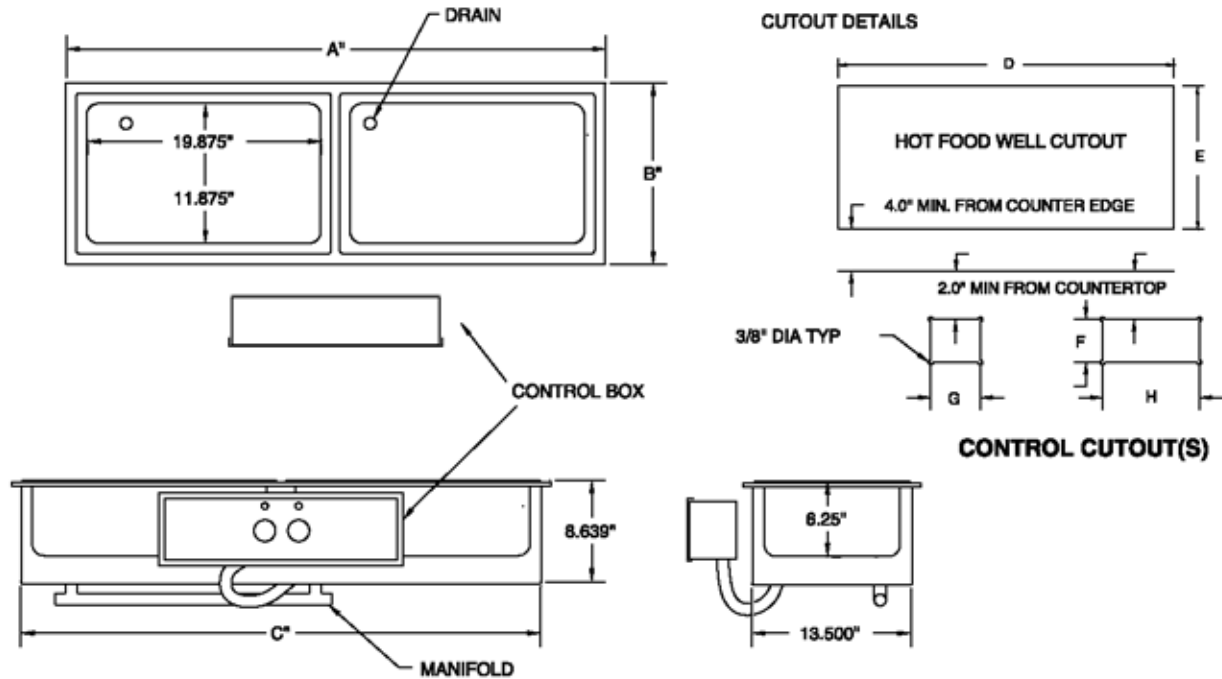

MODEL	OUTSIDE DIMENSIONS			WELL CUT-OUT		CONTROL CUT-OUT			SHIP WT.
	A	B	C	D	E	F	G	H	
HFWS-2	45.409"	15.055"	43.781"	44.500"	14.125"	5.62"	9.81"	NA	89 lbs/40.4 Kg
HFWS-3	67.451"	15.055"	65.823"	66.500"	14.125"	5.62"	NA	19.87"	120 lbs/54.4 Kg
HFWS-4	89.493"	15.055"	87.865"	88.500"	14.125"	5.62"	NA	19.87"	159 lbs/72 Kg

MODEL	ELECTRICAL RATINGS 1200 EA. @ 208 1600 EA. @ 240				ELECTRICAL RATINGS 1600 EA. @ 208			
	VOLTS	WATTS	AMPS	MAX AMPS 3-PHASE	VOLTS	WATTS	AMPS 1-PHASE	MAX AMPS 3-PHASE
HFWS-2	208/240	2400/3200	11.5/13.3	10.0/11.6	208	3200	15.4	13.4
HFWS-3	208/240	3600/4800	17.3/20	10.0/11.6	208	4800	23	13.4
HFWS-4	208/240	4800/6400	23.1/26.7	15.3/17.7	208	6400	30.8	20.4

*APW Wyott reserves the right to modify specifications or discontinue models without incurring obligation.



APW Wyott Foodservice Equipment Company · 729 Third Ave., Dallas, TX 75226
(800) 527-2100 · (214) 421-7366 · Fax (214) 565-0976 · www.apwwyott.com · info@apwwyott.com

Rev. 5/01/2008
1404