



Lowerator® Drop-In Dish Dispensers

PRODUCT:

QUANTITY:

Models: L SL HL

ITEM#:

Bid Specifications

Tube construction is stainless steel with polished flange and dispensing head. Easy drop-in insulation. The dispensing mechanism in APW Wyott's Lowerators® uses springs attached to a sliding support bar that rides both inside and outside the tube. This design feature prevents a stack of dishware from sticking in the down position, and releasing unexpectedly. Flange supports unit on countertop after simple cutout is made. Shielded unheated tubes are available. Heated tubes are provided with 5-foot length of flexible metal conduit with standard 1/2" fitting and 6" wire leads for easy connection to junction box for 120V service.

Applications

Models L, SL and HL Adjustube® Dispensers are used to dispense dishes, cups, glasses, bowls, plate covers and other round dinnerware. This tube-type, self-leveling dispenser is easily installed in serving counters, back bars, and other service points.

Standard Features

- Samples are not needed. Just select the tube for the diameter of dinnerware to be used from the table on the reverse side of this sheet.
- Spring rate adjustments can be easily made in the field without tools.
- Non-marking, stylized guideposts protect china from chipping.
- Stabilizing mechanism insures that contents remain level at all times.
- Samples are not needed. Just select the tube for the diameter of dinnerware to be used from the table on the reverse side of this sheet.

Reliability Backed by APW Wyott's Warranty

- APW Wyott's Dispensers are backed by a 1 year parts & labor warranty, including On-Site Service calls within 50 miles of authorized service technicians.
- Dispensers are Certified by the following agencies:



All Units



Heated Units only



Lowerator® Drop-In Dish Dispensers

Options:

- 208/240V service for HL models
 - T-L12 Cup/glass tray for -12 model tubes
- | | | | | |
|-------------------------------|--------------------------------|---------------------------------|--------------------------------|-------------------------------|
| <input type="checkbox"/> L-5 | <input type="checkbox"/> L-6 | <input type="checkbox"/> L-6.5 | <input type="checkbox"/> L-7 | <input type="checkbox"/> L-8 |
| <input type="checkbox"/> L-9 | <input type="checkbox"/> L-10 | <input type="checkbox"/> L-12 | <input type="checkbox"/> L-13 | |
| <input type="checkbox"/> SL-5 | <input type="checkbox"/> SL-6 | <input type="checkbox"/> SL-6.5 | <input type="checkbox"/> SL-7 | <input type="checkbox"/> SL-8 |
| <input type="checkbox"/> SL-9 | <input type="checkbox"/> SL-10 | <input type="checkbox"/> SL-12 | <input type="checkbox"/> SL-13 | |
| <input type="checkbox"/> HL-5 | <input type="checkbox"/> HL-6 | <input type="checkbox"/> HL-6.5 | <input type="checkbox"/> HL-7 | <input type="checkbox"/> HL-8 |
| <input type="checkbox"/> HL-9 | <input type="checkbox"/> HL-10 | <input type="checkbox"/> HL-12 | <input type="checkbox"/> HL-13 | |

See reverse side for product specifications.



APW Wyott Foodservice Equipment Company

729 Third Avenue • Dallas, TX 75226 • 800-527-2100 • 1-214-421-7366 • Fax 1-214-565-0976

For more information e-mail us at: Info@APWwyott.com

Rev. 1/1/2003

PRODUCT:

QUANTITY:

ITEM#:

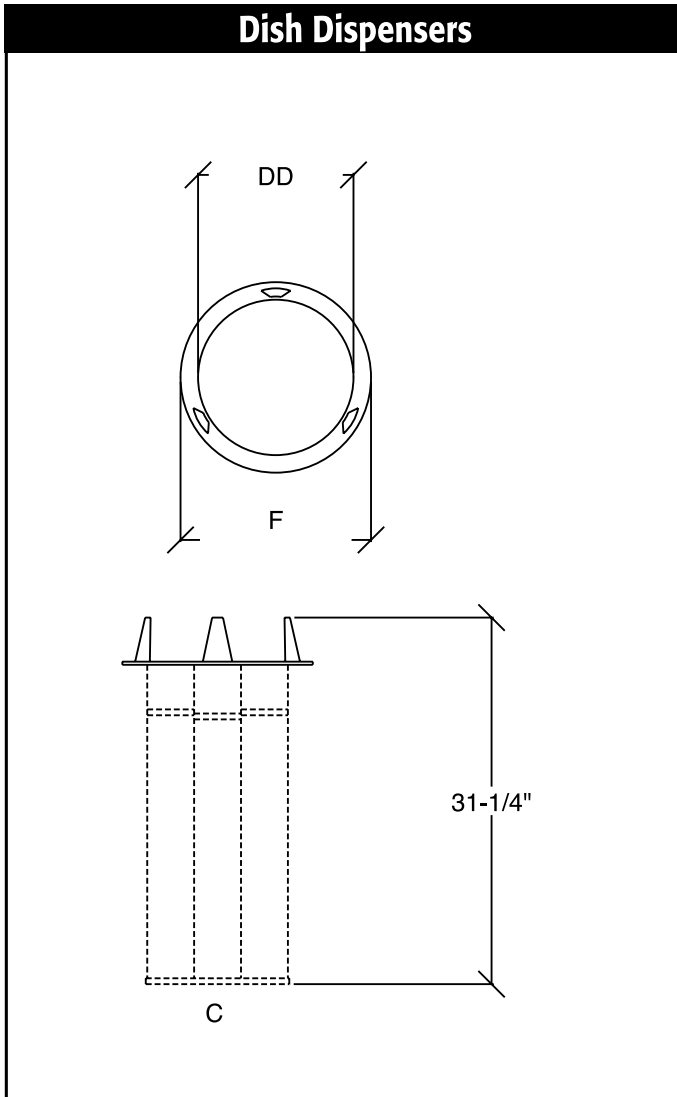

Dish Dispensers

PRODUCT SPECIFICATIONS

Construction:

Stainless Steel/Aluminum

Support Flange:

Stainless Steel

See chart below for measurements.

Adjustable Springs:

Stainless Steel

Spring Rate:

Adjustable to 5lbs./in. (See chart below.)

Temperature Range:

Plates after one hour in heated tube, depending on temperature of plates when placed in tube: Minimum setting: 80°–100°F Maximum Setting: 110°–160°F.

Capacities:

1. Maximum loads for all units are listed below.
2. Maximum capacity for all units is to six dozen dishes or to three dozen bowls.
3. Optional cup/glass tray holds approximately six pieces each.
4. 25-1/2" of vertical storage in each dispenser. (22" inside and 3-1/2" to top of guide posts.)

F.O.B. Cheyenne, WY

MODEL NUMBER	DINNERWARE DIA. (DD)	HOLE CUTOUT DIA. (C)	SUPPORTING FLANGE DIA. (F)	HEATED TUBE WATTAGE	AMPS @ 120V	MAX CAPACITY	SHIP WEIGHT (lbs)
L-5 / SL-5 / HL-5	up to 5	7-7/16	8-1/4	210	1.8	56 lbs.	10/15/18
L-6 / SL-6 / HL-6	5-1/8 to 5-3/4	8-3/16	9	240	2.0	75 lbs.	11/16/20
L-6.5 / SL-6.5 / HL-6.5	5-7/8 to 6-1/2	8-15/16	9-3/4	270	2.3	94 lbs.	12/17/26
L-7 / SL-7 / HL-7	6-5/8 to 7-1/4	9-11/16	10-1/2	300	2.5	131 lbs.	13/18/26
L-8 / SL-8 / HL-8	7-3/8 to 8-1/8	10-9/16	11-3/8	330	2.8	94 lbs.	15/24/27
L-9 / SL-9 / HL-9	8-1/4 to 9-1/8	11-9/16	12-3/8	380	3.2	131 lbs.	17/25/28
L-10 / SL-10 / HL-10	9-1/4 to 10-1/8	12-9/16	13-3/8	420	3.5	150 lbs.	20/25/30
L-12 / SL-12 / HL-12	10-1/4 to 11-7/8	14-5/16	15-1/8	500	4.2	175 lbs.	21/22/34
L-13 / SL-13 / HL-13	11-7/8 to 13	15-7/16	16-1/4	550	4.6	175 lbs.	22/22/22