



Synergy Steam

E-KLS Electric Stationary Floor Kettle



OPTIONS AND ACCESSORIES

(AT ADDITIONAL CHARGE)

- Etched markings
Gallons
Litres
Strainer
1/8" perforated disc strainer
1/4" perforated disk strainer
Solid disc strainer
Basket inserts
Swing faucets
Automatic water filler
3" tangent drawoff
Kettle brush kit
Contour measuring strip

Project _____

Item No. _____

Quantity _____

- Model 20E-KLS - 20 gallon (76 litres) electric stationary floor kettle
Model 40E-KLS - 40 gallon (151 litres) electric stationary floor kettle
Model 60E-KLS - 60 gallon (227 litres) electric stationary floor kettle
Model 80E-KLS - 80 gallon (303 litres) electric stationary floor kettle

CONSTRUCTION

- 316 stainless steel, one-piece welded construction
2/3 jacketed kettle
All exposed surfaces shall be stainless steel
Kettle body is sheathed in stainless steel and air gap insulated.
ASME shop inspected, stamped and registered with the National Board for operation up to a maximum working pressure of 30 PSI.
Outer sheathing and air insulating gap retains heat and keeps kettle exterior cooler to the touch.

OPERATION

- Kettle shall have an electric, self-contained steam source to provide kettle temperatures from 150 to approximately 270°F
Thermostatically controlled to shut off automatically when desired temperature is reached or on when temperature falls below desired setting
Factory charged with chemically-pure water and rust inhibitors to ensure long life and minimum maintenance
All controls shall be contained in a stainless steel enclosure within easy reach of the operator
Thermostat
Pilot light
Pressure/vacuum gauge
Contactor
Water level sight glass
Safety valve
Low water cut-off

STANDARD FEATURES

- One-piece, hinged design dome cover on 20 and 40 gallon units.
One-piece domed cover with counter balanced spring-assist on 60 and 80 gallon units
Faucet bracket
2" sanitary tangent drawoff
Removable 1/4" perforated stainless steel strainer
Standard voltage options
208 VAC, 3 phase, 60 Hz
240 VAC, 3 phase, 60 Hz
480 VAC, 3 phase, 60 Hz
One year parts and labor warranty*

* For all international markets, contact your local distributor.



BLODGETT

www.blodgett.com

44 Lakeside Avenue, Burlington, VT 05401 • Phone: (802) 658-6600 • Fax: (802) 864-0183



E-KLS STATIONARY FLOOR KETTLE



APPROVAL/STAMP

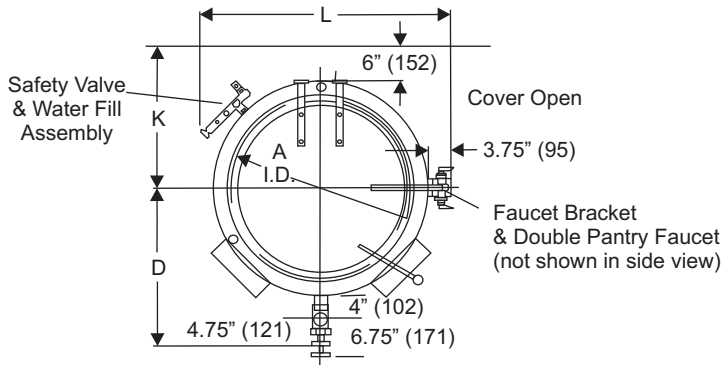

TOP VIEW

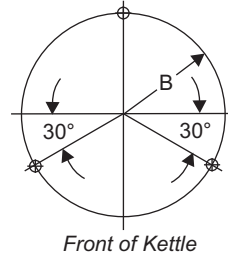

TOP VIEW OF LEGS

NOTES:

1. Hinged cover (shown) standard on 20 and 40 gallon kettle.
2. Power aid cover standard on 60-100 gallon kettles.
3. Single or double pantry faucets are optional.
4. 3" tangent drawoff is optional.
5. Dimensions are in inches (mm).

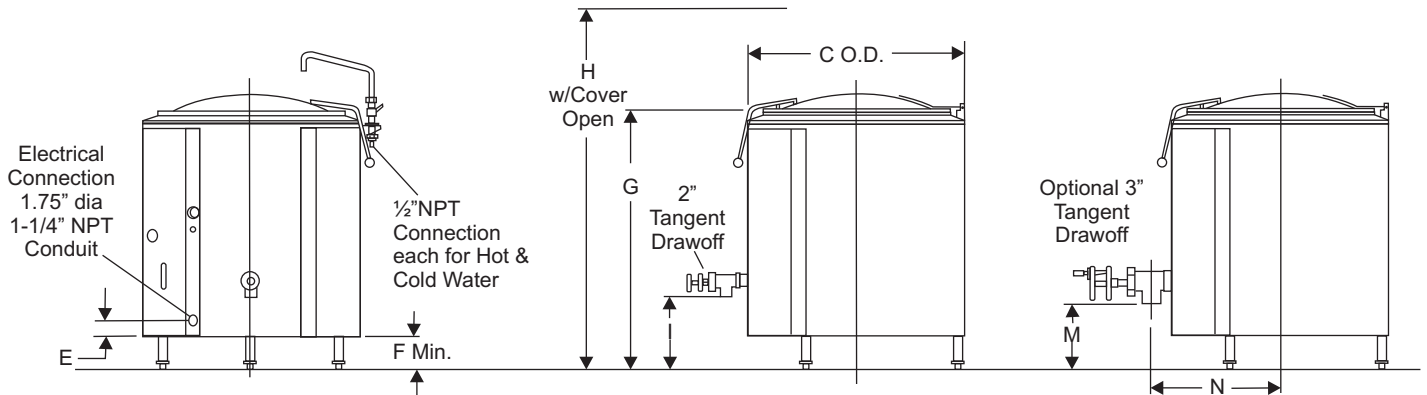

FRONT VIEW

SIDE VIEWS

SHORT FORM SPECIFICATIONS

Provide Blodgett model 20E-KLS (20 gallon), 40E-KLS (40 gallon), 60E-KLS (60 gallon) or 80E-KLS (80 gallon) electric heated, stainless steel, steam jacketed kettle. Unit shall include automatic thermostat control and pressure gauge mounted in convenient stainless steel control housing. Insulation outer sheathing, 2" tangent drawoff and hinged cover standard. Provide options and accessories as indicated.

Model	208V / 3 PH		240V / 3 PH		480V / 3 PH	
	kW	Amps	kW	Amps	kW	Amps
20E-KLS	10.8	30	12	29	12	14
40E-KLS	21.6	60	24	58	24	28
60E-KLS	32.4	90	36	87	36	44
80E-KLS	32.4	90	36	87	36	44
100E-KLS	32.4	90	36	87	36	44

	20E-KLS	40E-KLS	60E-KLS	80E-KLS
A	20 (508)	26 (660)	30 (762)	32 (813)
B	24 (610)	30 (762)	34 (864)	36 (914)
C	26 (660)	32 (813)	36 (914)	38 (965)
D	21.75 (552)	24.75 (629)	26.75 (679)	27.75 (705)
E	13 (330)	10 (254)	10 (254)	10 (254)
F	9 (229)	6 (152)	6 (152)	6 (152)
G	37 (940)	37 (940)	40 (1016)	44 (1118)
H	60 (1524)	66 (1676)	68 (1727)	74 (1879)
J	16 (406)	12 (305)	12 (305)	12 (305)
K	18 (432)	25 (508)	22 (559)	23 (584)
L	32.13 (816)	38.13 (968)	42.13 (1070)	44.13 (1121)
M	15 (381)	11 (279)	11 (279)	11 (279)
N	17.75 (451)	20.75 (527)	22.75 (578)	23.75 (603)

SHIPPING INFORMATION:

Approx. Weight:

- 20E-KLS 410 lbs. (186 kg)
- 40E-KLS 548 lbs. (249 kg)
- 60E-KLS 640 lbs. (290 kg)
- 80E-KLS 860 lbs. (390 kg)

NOTE: The company reserves the right to make substitutions of components without prior notice.

BLODGETT

www.blodgett.com

44 Lakeside Avenue, Burlington, VT 05401 • Phone: (802) 658-6600 • Fax: (802) 864-0183