

CWTF20-TC

18.2" x 21.4" x 9.0"
(46.2cm x 54.4cm x 22.9cm)



- Models are space saving 9" wide (22.9cm)
- Accepts thermal carafe up to 8.5" (21.6 cm) tall
- All stainless steel construction
- Hot water faucet (requires active plumbing connection)
- Pourover feature
- SplashGard® funnel deflects hot liquids away from the hand
- Use in quick turn environments where high quality coffee is continuously refreshed
- PROP 65 Warning Decal included in packaging with equipment
- Servers not included unless otherwise noted

Agency:

 Server(s) sold separately

Specifications

Product #: 12950.0380

Water Access: Plumbed

Finish: Stainless

Funnel: Black Plastic

Faucet: Upper

Additional Features

Electrical & Capacity

| Volts | Amps | Watts | Cord Attached | Plug Type | 8oz cups/hr 236ml cups/hr | Input H ₂ O Temp. | Phase | # Wires plus Ground | Hertz |
|-------|------|-------|---------------|-----------|------------------------------|------------------------------|-------|---------------------|-------|
| 120 | 15.4 | 1850 | No | - | 85 | 60°F (15.5°C) | 1 | 2 | 60 |

Plumbing Requirements

| PSI | kPa | Fitting Supplied | Water Flow Required (GPM) |
|-------|---------|-------------------------|---------------------------|
| 20-90 | 138-621 | 1/4" Male Flare Fitting | - |

CAD Drawings

| 2D | Revit | KLC |
|----|-------|-----|
| ● | | |



BUNN® reserves the right to change specifications and product design without notice. Such revisions do not entitle the buyer to corresponding changes, improvements, additions or replacements for previously purchased equipment. For most current specifications and other info visit bunn.com.

Created on:
07/18/2019

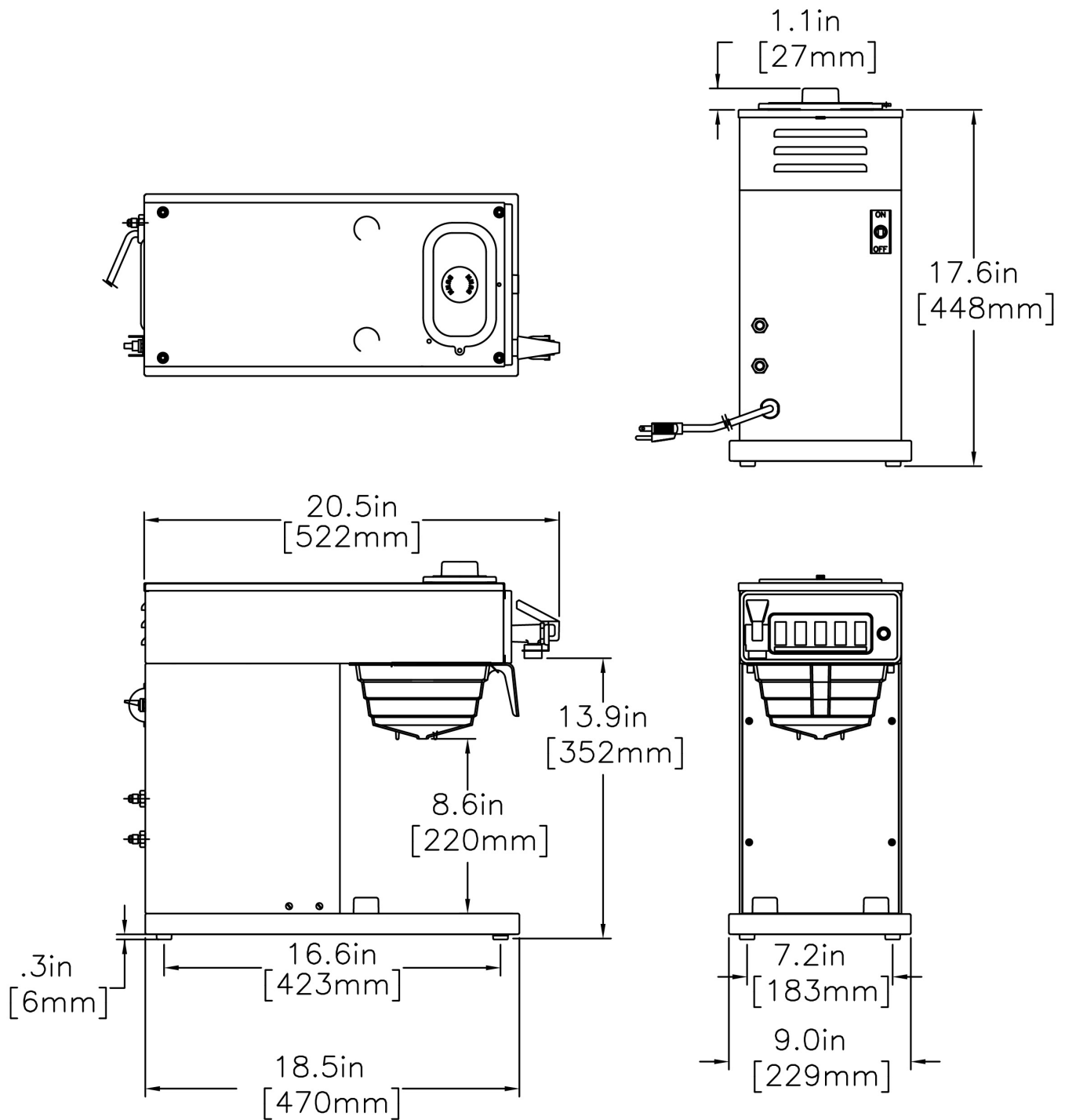

| | Unit | | | Shipping | | | | |
|---------|---------|----------|----------|----------|----------|----------|------------|-----------------------|
| | Width | Height | Depth | Width | Height | Depth | Weight | Volume |
| English | 9.0 in. | 18.2 in. | 21.4 in. | 11.9 in. | 24.8 in. | 25.9 in. | 32.500 lbs | 3.807 ft ³ |
| Metric | 22.9 cm | 46.2 cm | 54.4 cm | 30.2 cm | 63.0 cm | 65.8 cm | 14.742 kgs | 0.108 m ³ |



BUNN® reserves the right to change specifications and product design without notice. Such revisions do not entitle the buyer to corresponding changes, improvements, additions or replacements for previously purchased equipment. For most current specifications and other info visit bunn.com.

Created on:
07/18/2019

Related Products & Accessories: CWTF20-TC(12950.0380)



FILTERS,REGULAR1M
500/2 50/CL

Product #: 20115.0000



FUNNEL W/DECALS,
BLACK PLASTIC

Product #: 20583.0003



WATER FILTER
SYSTEM,EQ-17-TL

Product #: 30200.1000



BUNN® reserves the right to change specifications and product design without notice. Such revisions do not entitle the buyer to corresponding changes, improvements, additions or replacements for previously purchased equipment. For most current specifications and other info visit bunn.com.

Created on:
07/18/2019

Serving & Holding Options: CWTF20-TC(12950.0380)



THERMAL CARAFE, BLK
1.9L 12PK

Product #:36029.0000



THERMAL CARAFE, BLK
1.9L 1PK

Product #:36029.0001



THERMAL CARAFE, ORN
1.9L 12PK

Product #:36252.0000



THERMAL CARAFE, ORN
1.9L 1PK

Product #:36252.0001



CARAFE, SST 1.9L SHRT
BLK 1

Product #:40163.0000



CARAFE, SST 1.9L SHRT
ORN 1/

Product #:40163.0001



CARAFE, SST 1.9L SHRT
BLK 12/

Product #:40163.0100



CARAFE, SST 1.9L SHRT
ORN 12/

Product #:40163.0101



BUNN® reserves the right to change specifications and product design without notice. Such revisions do not entitle the buyer to corresponding changes, improvements, additions or replacements for previously purchased equipment. For most current specifications and other info visit bunn.com.

Created on:
07/18/2019