

# Ultra-2 HP BLK Liquid Autofill

32.0" x 24.5" x 16.0"  
(81.3cm x 62.2cm x 40.6cm)



- Patented beverage monitoring technology and reversing auger design ensure consistent, great tasting frozen beverages
- Two large product hoppers hold 3 gallons (11.4L) each to maximize serving capacity
- User interface communicates need for cleaning and maintenance, and provides simple programming, cleaning and preventive maintenance guides to ensure reliable operation and performance – minimizing down time and maximizing serving capacity and profits
- Liquid auto-fill interface with brix pumps reduces labor, and ensures your products are ready to serve at peak demand
- LED lighted merchandisers in hopper lids bring high visibility to front- of-house applications
- Extended Dispense Handle
- Sanitation listings NSF 18 and NSF 6 (Dairy)

Agency:



## Specifications

**Product #:** 34000.0515

**Autofill:** Liquid

**Water Access:** Plumbed

**Finish:** Black

**Hoppers:** Two

**Refrigerant:** R404A

**Handle:** Extended Handle

**Legs:** 4" Black Legs

## Additional Features

## Electrical & Capacity

Volts	Amps	Watts	Cord Attached	Plug Type	8oz cups/hr 236ml cups/hr	Input H <sup>2</sup> O Temp.	Phase	# Wires plus Ground	Hertz
120	12	1440	Yes	NEMA 5-15P	-	60°F (15.5°C)	1	2	50/60

## Plumbing Requirements

PSI	kPa	Fitting Supplied	Water Flow Required (GPM)
20-90	138-621	1/4" Male Flare Fitting	-

## CAD Drawings

2D	Revit	KLC
●		



BUNN® reserves the right to change specifications and product design without notice. Such revisions do not entitle the buyer to corresponding changes, improvements, additions or replacements for previously purchased equipment. For most current specifications and other info visit [bunn.com](http://bunn.com).

Created on:  
05/16/2019

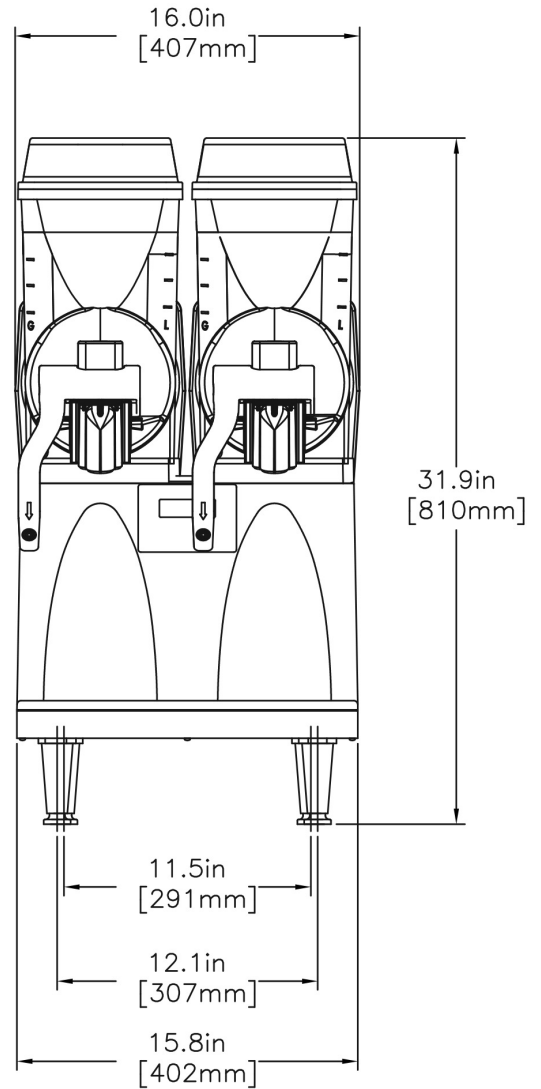
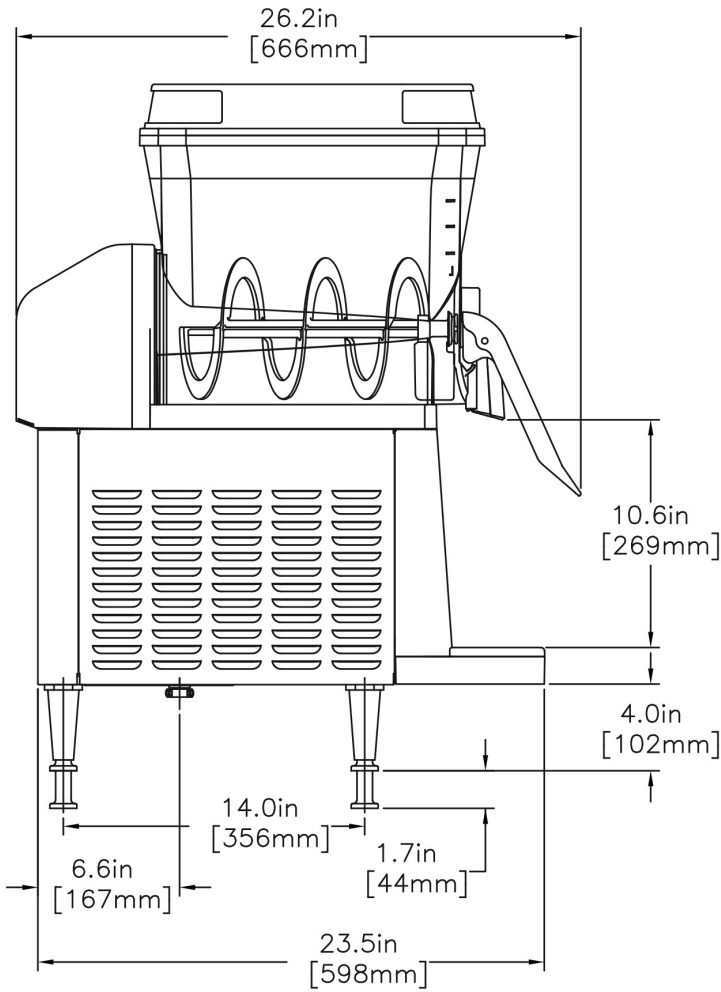
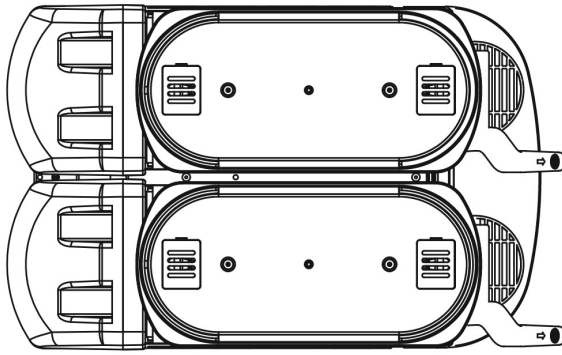

Unit			Shipping					
	Width	Height	Depth	Width	Height	Depth	Weight	Volume
English	16.0 in.	32.0 in.	24.5 in.	-	-	-	138.670 lbs	-
Metric	40.6 cm	81.3 cm	62.2 cm	-	-	-	62.901 kgs	-



BUNN® reserves the right to change specifications and product design without notice. Such revisions do not entitle the buyer to corresponding changes, improvements, additions or replacements for previously purchased equipment. For most current specifications and other info visit [bunn.com](http://bunn.com).

Created on:  
05/16/2019

Related Products & Accessories: Ultra-2 HP BLK Liquid Autofill(34000.0515)



DRIP TRAY ASSY,  
LOWER-BLK

Product #: 28086.0001

COVER, DRIP TRAY  
ULTRA 2 BLK

Product #: 32068.0001



BUNN® reserves the right to change specifications and product design without notice. Such revisions do not entitle the buyer to corresponding changes, improvements, additions or replacements for previously purchased equipment. For most current specifications and other info visit [bunn.com](http://bunn.com).

Created on:  
05/16/2019

## Serving & Holding Options: Ultra-2 HP BLK Liquid Autofill(34000.0515)

\*Serving and Holding selections are currently unavailable. Please contact your sales representative to find out more information.\*



BUNN® reserves the right to change specifications and product design without notice. Such revisions do not entitle the buyer to corresponding changes, improvements, additions or replacements for previously purchased equipment. For most current specifications and other info visit [bunn.com](http://bunn.com).

Created on:  
05/16/2019