

ITEM# _____

PROJECT _____

DATE _____

High Volume Water Quality Systems



Model EQHP-25L or EQHP-25
Water Quality System

Features

Easy Clear High Performance 25,000 Gallon Water Quality Systems

- Consistent great-tasting brewed coffee and tea from water with reduced sediment and chlorine taste and odor.
- Incorporates multi-zone pharmaceutical grade pleated nylon pre-filter.
- Pre-filter offers exceptional sediment holding capacity and particle reduction to 0.2 microns.
- Equipment protection from reduced sediment particles that can clog the sprayhead.
- NSF Standard 42 and/or FDA CFR-21 compliance provides assurance of safety.
- Certified by NSF to Standard 53 for cyst reduction.
- Reduced scale formation by the controlled release of proprietary scale inhibitors with “L” model.
- System includes a head assembly, integral mounting bracket, and single cartridge filter.
- Quick Connect valve-in-head design simultaneously shuts off and vents water with 1/4 turn, allowing for simple and trouble-free cartridge change-outs.
- Optional pressure gauge allows monitoring of downstream water pressure.
- Filter cartridges incorporate carbon block media and require no pre-activation
- 3/8” FNPT horizontal inlet and outlet ports allow direct or easily adaptable connections to existing plumbing lines.
- System maximum operating pressure is 100 psi (862 kPa) and operating temperature 100°F (38°C).

For current specification sheets and other information, go to www.bunn.com.

Related Products

Replacement Cartridge
EQHP-25LCRTG
Product No.: 39000.1002

Valve In-Head Assembly
EQHP-VHD
Product No.: 39000.1000

Replacement Cartridge
EQHP-25CRTG
Product No.: 39000.1005

Gauge
Product No.: 39000.0100



Model	Agency Listing
EQHP-25L	
EQHP-25	

Dimensions & Specifications

Product#	Model	Service Flow Rate & Capacity	Micron Rating	BUNN Applications	Other Applications
High Volume					
EQHP-25L	39000.0002	2.1 gpm/25,000 Gallons	0.2	Dual, Dual TF, Dual SH, LCR-2, LCA-2, Urns, 3-Gallon Systems, H10X. For Example (6 month period): 345 Cups of Coffee, 110 Glasses of Ice Tea and 200 Cups of Cappucino per day* <u>and</u> 1200lb. Flaker Ice Machine. Combinations totalling 25,000 gallon usage per 6 months.	ICE MAKERS: Cubers to 1000lbs. Flakers to 1800lbs. Summary, for use in high volume applications where scale inhibitor is needed.
EQHP-25	39000.0005	2.1 gpm/25,000 Gallons	0.2	TCD, LCA-2 IC, Granita Auto-Fill Systems. In hard water situations combine with Scale-PRO to reduce scale build up in hot beverage and ice applications.	Single High Flow Carbonator Dispenser. 200,000 16oz Soft Drinks* before change out. (1092 drinks per day) Summary, for use in high volume applications where scale inhibitor is not needed. Any beverage or application using ambient water.

Note: Inlet and outlet plumbing connections are 3/8" FNPT.

**16oz. drinks with location operating 365 days/year.
Assumption includes no ice in beverage.*

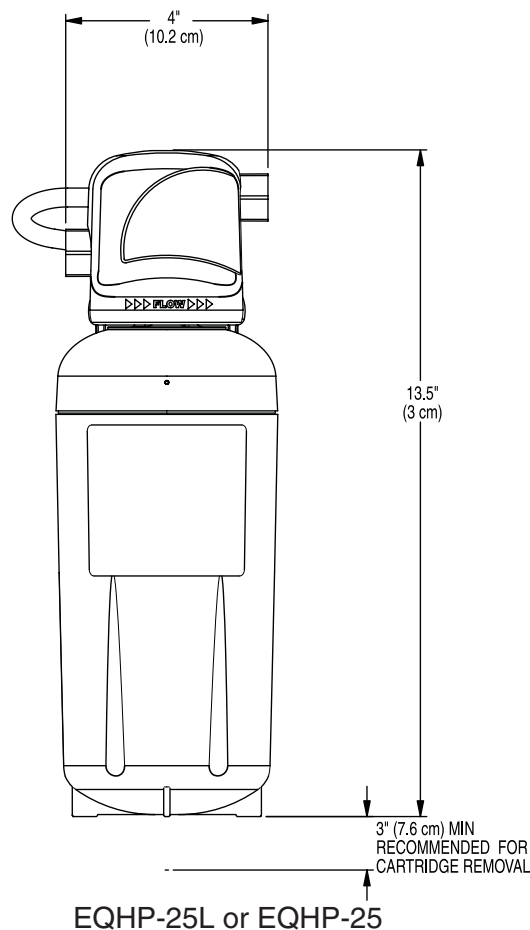

Bunn-O-matic® Corporation - 1400 Stevenson Drive Springfield, Illinois 62703 • 800-637-8606 • 217-529-6601 • Fax 217-529-6644 • www.bunn.com

BUNN® practices continuous product research and improvement. We reserve the right to change specifications and product design without notice. Such revisions do not entitle the buyer to corresponding changes, improvements, additions or replacements for previously purchased equipment.

All dimensions shown in inches.

7/10 © Bunn-O-Matic Corporation