

ITEM# _____

PROJECT _____

DATE _____

Ultra-High Volume Water Quality Systems



Model EQHP-54L or EQHP-54
Water Quality System

Features

Easy Clear High Performance 54,000 Gallon Water Quality Systems

- Consistent great-tasting brewed coffee and tea from water with reduced sediment and chlorine taste and odor.
- Incorporates multi-zone pharmaceutical grade pleated nylon pre-filter.
- Pre-filter offers exceptional sediment holding capacity and particle reduction to 0.2 microns.
- Equipment protection from reduced sediment particles that can clog the sprayhead.
- Reduced scale formation by the controlled release of proprietary scale inhibitors with "L" model.
- System includes a head assembly, integral mounting bracket, and single cartridge filter.
- Quick Connect valve-in-head design simultaneously shuts off and vents water with 1/4 turn, allowing for simple and trouble-free cartridge change-outs.
- Optional pressure gauge allows monitoring of downstream water pressure.
- Filter cartridges incorporate carbon block media and require no pre-activation.
- NSF Standard 42 and/or FDA CFR-21 compliance provides assurance of safety.
- Certified by NSF to Standard 53 for cyst reduction.
- 3/8" FNPT horizontal inlet and outlet ports allow direct or easily adaptable connections to existing plumbing lines.
- System maximum operating pressure is 100 psi (862 kPa) and operating temperature 100°F (38°C).

For current specification sheets and other information, go to www.bunn.com.

Related Products



Replacement Cartridge
EQHP-54LCRTG
Product No.: 39000.1003

Valve In-Head Assembly
EQHP-VHD
Product No.: 39000.1000

Replacement Cartridge
EQHP-54CRTG
Product No.: 39000.1006

Gauge
Product No.: 39000.0100



Model	Agency Listing
EQHP-54L	
EQHP-54	

Dimensions & Specifications

Model	Product #	Service Flow Rate & Capacity	Micron Rating	BUNN Applications	Other Applications
Ultra High Volume					
39000.0003	EQHP-54L	5.0 gpm/54,000 Gallons	0.2	<p><i>For Example (6 month period):</i> Serving up to 550 cups of coffee, 200 glasses of iced tea and 300 cups of cappucino per day* <u>and</u> location containing three 1200 lb. Flakers.</p> <p>Combinations totalling 54,000 gallon usage per 6 months.</p>	<p>ICE MAKERS: Cubers to 1450lbs+. Flakers to 2400lbs+.</p> <p>Summary, for use in super capacity applications where scale inhibitor is needed.</p>
39000.0006	EQHP-54	5.0 gpm/54,000 Gallons	0.2	In hard water situations combine with Scale-PRO to reduce scale build up in hot beverage and ice applications.	<p>Two high-flow carbonaters, 432,000 16oz. Soft drinks before changeout* (2360 Drinks per day).</p> <p>Summary, for use in Ultra-high volume applications where scale inhibitor is not needed. Any beverage or application using ambient water.</p>

Note: Inlet and outlet plumbing connections are 3/8" FNPT.

*16oz drinks with location operating 365 days/year.
Assumption includes no ice in beverage.

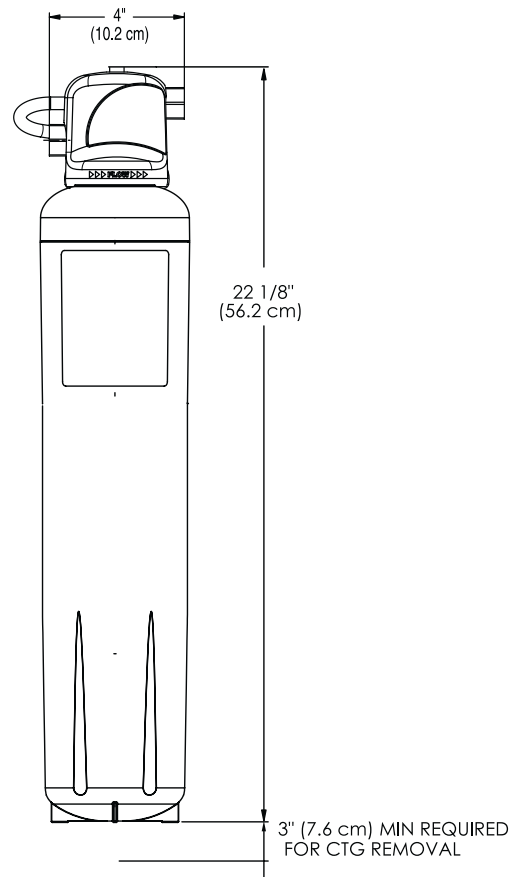

EQHP-54L or EQHP-54

Bunn-O-Matic® Corporation - 1400 Stevenson Drive Springfield, Illinois 62703 • 800-637-8606 • 217-529-6601 • Fax 217-529-6644 • www.bunn.com

BUNN® practices continuous product research and improvement. We reserve the right to change specifications and product design without notice. Such revisions do not entitle the buyer to corresponding changes, improvements, additions or replacements for previously purchased equipment.

All dimensions shown in inches.