

Medium/High Volume Water Quality Systems



Model EQHP-10L or EQHP-10
Water Quality System

Features

Easy Clear High Performance 10,000 Gallon Water Quality Systems

- Consistent great-tasting brewed coffee and tea from water with reduced sediment and chlorine taste and odor.
- Equipment protection from reduced sediment particles that can clog the sprayhead.
- Reduced scale formation by the controlled release of proprietary scale inhibitors with “L” model.
- System includes a head assembly, integral mounting bracket, and single cartridge filter.
- Quick Connect valve-in-head design simultaneously shuts off and vents water with 1/4 turn, allowing for simple and trouble-free cartridge change-outs.
- Filter cartridges incorporate carbon block media and require no pre-activation.
- Optional pressure gauge allows monitoring of downstream water pressure.
- NSF Standard 42 and/or FDA CFR-21 compliance provides assurance of safety.
- 3/8” FNPT horizontal inlet and outlet ports allow direct or easily adaptable connections to existing plumbing lines.
- System maximum operating pressure is 125 psi (862 kPa) and operating temperature 100°F (38°C).

For current specification sheets and other information, go to www.bunn.com.

Related Products



Replacement Cartridge
EQHP-10LCRTG
Product No.: 39000.1001

Valve In-Head Assembly
EQHP-VHD
Product No.: 39000.1000

Replacement Cartridge
EQHP-10CRTG
Product No.: 39000.1004

Gauge
Product No.: 39000.0100



| Model | Agency Listing |
|----------|---|
| EQHP-10L |  |
| EQHP-10 |  |

Dimensions & Specifications

| Model | Product # | Service Flow Rate & Capacity | Micron Rating | Bunn Applications | Other Applications |
|------------|-----------|------------------------------|---------------|--|---|
| | | | | Medium to High Volume | |
| 39000.0001 | EQHP-10L | 1.5 gpm/10,000 Gallons | 1.0 | CWT(F), CDBC(F), AXIOM Series, Infusion Series, Liquid Coffee, TB3(Q), TU5Q, iMIX, Dual, Dual TF, Dual SH, LCR-2, LCA-2, Urns, 3-Gallon Systems, HW2, H5E/X, H10X. <i>For Example (6 month period):</i> 195 Cups of Coffee, 80 Glasses of Ice Tea and 160 Cups of Cappucino per day* Combinations totalling 10,000 gallon usage per 6 months. | ICE MAKERS: Cubers to 750lbs. Flakers to 1200lbs. Summary, for use in medium/high volume applications where scale inhibitor is needed. |
| 39000.0004 | EQHP-10 | 1.5 gpm/10,000 Gallons | 1.0 | TCD-1/2, LCA-2 IC, Granita Auto-Fill Systems. In hard water situations combine with Scale-PRO to reduce scale build up in hot beverage and ice applications. | Single Low Flow Carbonater: 80,000 16oz Soft Drinks before change out. (437 Drinks per day)*. Summary, for use in medium volume applications where scale inhibitor is not needed. Any beverage or application using ambient water. |

Note: Inlet and outlet plumbing connections are 3/8" FNPT.

Do not use with water that is microbiologically unsafe or of unknown quality without adequate disinfection before or after the system. Systems certified for cyst reduction may be used on disinfected water that may contain filterable cysts. EPA Establishment Number 070595-CT-001.

BUNN recommends regularly scheduled maintenance and replacement of the filter cartridge(s) in order for the product to perform as advertised/sold. Change the filter cartridge at least every 6 months. BUNN shall not be liable for system failures due to improper maintenance.

*16oz. drinks with location operating 365 days/year. Assumption includes no ice in beverage.

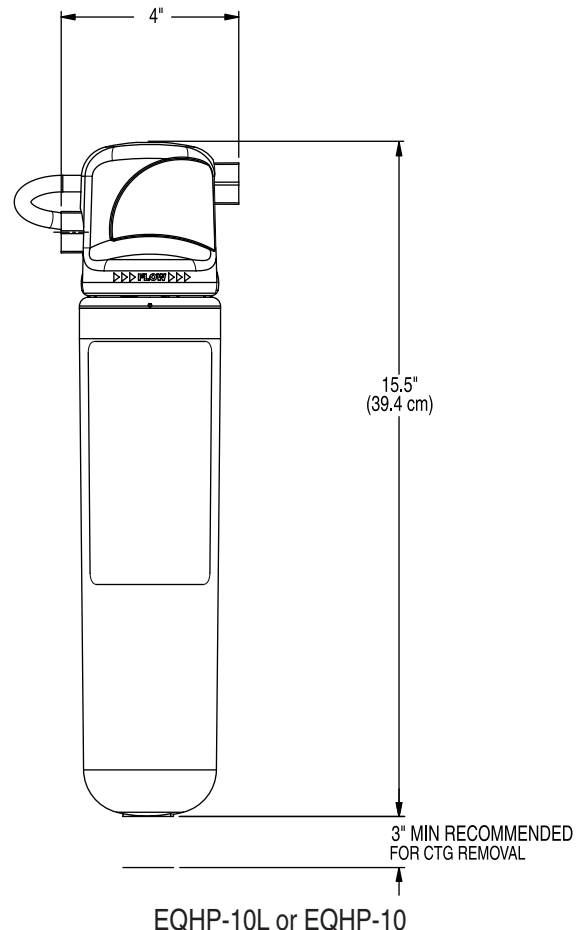

Bunn-O-Matic® Corporation - 1400 Stevenson Drive Springfield, Illinois 62703 • 800-637-8606 • 217-529-6601 • Fax 217-529-6644 • www.bunn.com

BUNN® practices continuous product research and improvement. We reserve the right to change specifications and product design without notice. Such revisions do not entitle the buyer to corresponding changes, improvements, additions or replacements for previously purchased equipment.

All dimensions shown in inches.