



FROST TOP DROP-IN

Models FTB-1, -2, -3 FTB-S2, -S3

Hatco Drop-in Frost Tops keep prechilled beverages, snacks, hors d'oeuvres and side dishes cool and ready to serve

FLEXIBILITY

The Hatco Frost Top units hold full-size sheet pans and other flat-bottom serving containers, helping to keep food products cool and fresh. Available in one-, two- and three-pan models as well as two- and three-pan slim configurations to best fit any buffet line.

For easy and flexible installation, the condensing unit may be rotated 90° or 180° (movable in some models). The electronic adjustable temperature control can be mounted to either side of the condensing unit or remotely up to four feet (1219 mm) from the unit.

QUALITY

The following features assure the finest performance for years to come:

- Accommodates full-size and half-size sheet pans.
- Units include a 1" (25 mm) NPT drain (excluding FTB-1) and refrigeration system.
- The condensing unit, mounted on the center of the unit, rotates 180° (movable in some models).
- Electronic adjustable temperature control available to mount on either side of the condensing unit or remotely mounted up to 4 feet from the unit (cannot be mounted over the condensing coil).
- Mobile condensing unit can be movable 3" (76 mm) increments in the FTB-2 and 6.5" (165 mm) increments in the S2, -3, S3 (see drawing on back).
- Long, flexible refrigerant line (ability to pullout condensing unit) for service.
- Lighted On/Off rocker switch.



Model FTBR-2 with accessory full-size sheet pans



Model FTB-2



Model FTB-S2 with accessory sheet pans

Ordering Instructions

Please specify the following with each order:

1. Number of Full-Size Sheet Pans

Accommodated:

1-, 2-, or 3-pan as rectangular sheet pans with a Slim or Standard configuration

2. Drain: 1" NPT drain for FTB-2, FTB-3, FTB-S2, FTB-S3 only (drain plumbing to be installed per local codes)

3. Agency: UL, C-UL, NSF 7 Component

4. Electronic Control Assembly: can be mounted on either side of the condensing unit or remotely mounted up to 4' from the unit (cannot be mounted over the condensing unit)

Countertop Cutout Dimensions

Model	Minimum Width	Maximum Width	Minimum Depth	Maximum Depth	Below Counter
FTB-1	19.44" (494 mm)	20.125" (511 mm)	27.44" (697 mm)	28" (711 mm)	16.75" (426 mm)
FTB-2	37.375" (949 mm)	38" (965 mm)	27.31" (694 mm)	28" (711 mm)	16.75" (426 mm)
FTB-3	55.375" (1407 mm)	56" (1422 mm)	27.31" (694 mm)	28" (711 mm)	16.75" (426 mm)
FTB-S2	53.31" (1354 mm)	54" (1372 mm)	19.44" (494 mm)	20.125" (511 mm)	16.75" (426 mm)
FTB-S3	79.19" (2011 mm)	79.875" (2029 mm)	19.44" (494 mm)	20.125" (511 mm)	16.75" (426 mm)



ONE YEAR ON-SITE PARTS AND LABOR WARRANTY. AN ADDITIONAL FOUR-YEAR PARTS ONLY WARRANTY ON THE COMPRESSOR IS AVAILABLE AT TIME OF UNIT PURCHASE.



HATCO CORPORATION P.O. Box 340500 Milwaukee, WI 53234-0500 U.S.A.
 (800) 558-0607 • (414) 671-6350 • Fax (800) 543-7521 • Int'l. Fax (414) 671-3976
 www.hatcocorp.com • E-mail: equipsales@hatcocorp.com

Form No. FTB Spec Sheet

Printed in U.S.A.
 October 2013



FROST TOP DROP-IN

Models FTB-1, -2, -3 FTB-S2, -S3

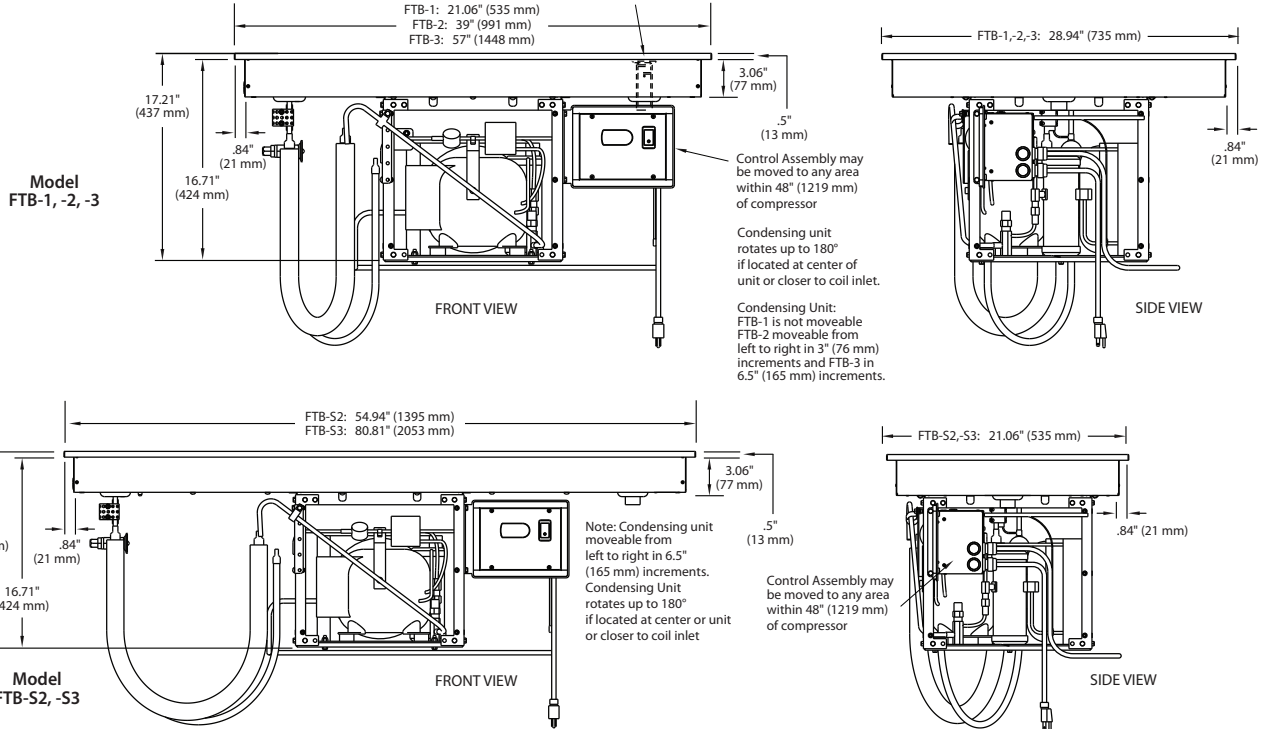

SPECIFICATIONS

Frost Top Drop-In

Model*	HP	Volts	Watts	Amps	Shipping Weight†
FTB-1	1/4	120	804	6.7	132 lbs.(60 kg)
FTB-2	1/4	120	804	6.7	180 lbs.(82 kg)
FTB-3	1/4	120	804	6.7	213 lbs.(97 kg)

Frost Top Drop-In Slim

Model*	HP	Volts	Watts	Amps	Shipping Weight†
FTB-S2	1/4	120	804	6.7	182 lbs.(83 kg)
FTB-S3	1/4	120	804	6.7	239 lbs.(108 kg)

* Model number indicates number of full-size food pans unit will accommodate.
 All units: R-404A refrigerant.
 † Shipping weights are approximate.

DIMENSIONS

FTB-1: 21.06"W x 28.94"D x 17.21"H (535 x 735 x 437 mm).
 FTB-2: 39"W x 28.94"D x 17.21"H (991 x 735 x 437 mm).
 FTB-3: 57"W x 28.94"D x 17.21"H (1448 x 735 x 437 mm).
 FTB-S2: 54.94"W x 21.06"D x 17.21"H (1395 x 535 x 437 mm).
 FTB-S3: 80.81"W x 21.06"D x 17.21"H (2053 x 535 x 437 mm).

Condensing Unit:

FTB-1, -2: Rotatable up to 180°
 FTB-3, -S2, -S3: Rotatable up to 180° if located at center of unit or closer to coil inlet.
 FTB-2: Moveable from left to right in increments of 3" (76 mm).
 FTB-3, -S2, -S3: Moveable from left to right in increments of 6.5" (165 mm).

Electronic Control:

May be field mounted on either side of the condensing unit or remote mounted up to 4' (1219 mm) from unit. May not be mounted over the condensing coil

VOLTAGE

120V, single phase (uses NEMA 5-15P)

PLUG CONFIGURATIONS

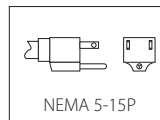

OPTIONS (NOT FOR RETROFIT)

- Additional Four-Year Parts Only Warranty on Compressor Available at Time of Unit Purchase

ACCESSORIES

- Full-size sheet pan
- Half-size sheet pan

PRODUCT SPECS

Drop-in Frost Top

The Drop-In Frost Top shall be a Model ... as manufactured by the Hatco Corporation, Milwaukee, WI 53234 U.S.A. With 24/7 parts and service assistance (U.S. and Canada only), the Frost Top shall be rated at ... watts, ... volts and be ... inches (millimeters) in overall width. It shall utilize R-404A refrigerant and consist

of aluminized steel housing, electronic temperature control, condensing unit, compressor, and flexible refrigerant lines. Accessories may include sheet pans.

HATCO CORPORATION P.O. Box 340500 Milwaukee, WI 53234-0500 U.S.A. • (800) 558-0607 • (414) 671-6350
 Fax (800) 543-7521 • Int'l. Fax (414) 671-3976 • www.hatcocorp.com • E-mail: equipsales@hatcocorp.com