



C0530 - 500lb Cube Ice Machine

Prodigy Plus® Modular Cube Ice Machine

The world's smartest cuber.

As the world's only self-monitoring cuber, the new Scotsman Prodigy Plus® cube ice machines make it easier than ever to maintain your equipment and save money. Whether it's the advanced ice level control or an optional feature board for quick diagnostics, this is ice-making re-imagined. And with intuitive technology like AutoAlert™ indicator lights, a reduced operational footprint and easy-access service from the front panel, Prodigy Plus® cubers are simply the smartest, most reliable way to create fresh-tasting ice — every time.



The Prodigy Plus® difference.

- AutoAlert™ indicator lights for better visibility
- Operational footprint among the industry's smallest
- Industry-exclusive QR code instantly connects users to service information and warranty history
- One-touch cleaning reduces labor costs and saves time
- Front-located air filter for more efficient operation
- Self-aligning front panel for easy access to key components
- Patented WaterSense purge control automatically reduces scale buildup
- Patented Harvest Assist efficiently moves cube ice to the bin
- Smart-Board™ advanced feature module available for additional diagnostic capabilities
- Optional Vari-Smart™ ice level control allows operators to customize ice levels
- Antimicrobial protection guards internal surfaces between cleanings
- A full range of water- and energy-saving features

C0530 - 500lb Cube Ice Machine



24 Hour Volume Production

Air Cooled		Remote			Water Cooled			
70°F/21°C 50°F/10°C	Air Water	90°F/32°C 70°F/21°C	70°F/21°C 50°F/10°C	Air Water	90°F/32°C 70°F/21°C	70°F/21°C 50°F/10°C	Air Water	90°F/32°C 70°F/21°C
525/238 lb/kg		380/172 lb/kg	500/227 lb/kg		400/181 lb/kg	500/227 lb/kg		410/186 lb/kg



Modular Bin Options

Model Number*	Dimensions W" x D" x H"	Bin Application Capacity		Finish	Ship Weight lb/kg
		lb/kg			
B330P	30 x 34 x 30**	344/156		Poly	130/59
B530S or P	30 x 34 x 44**	536/244		Metallic or Poly	150/68

* Contact Scotsman for bin top requirements. ** Add 6" Height for bin legs.



B330P



B530P



Cube Ice

Common ice form, ideal for mixed drinks.



Small Cube
7/8" x 7/8" x 3/8"
(2.22 x 2.22 x .95 cm)



Medium Cube
7/8" x 7/8" x 7/8"
(2.22 x 2.22 x 2.22 cm)



Certification



Warranty

- 3 years parts and labor on all components.
- 5 years parts and labor on the evaporator.
- 5 years parts on the compressor and condenser.
- Warranty valid in North, South & Central America for commercial installations.
- Contact factory for warranty in other regions.
- Residential Applications: 1 year parts and labor



C0530 - 500lb Cube Ice Machine

Prodigy Plus® Modular Cube Ice Machine

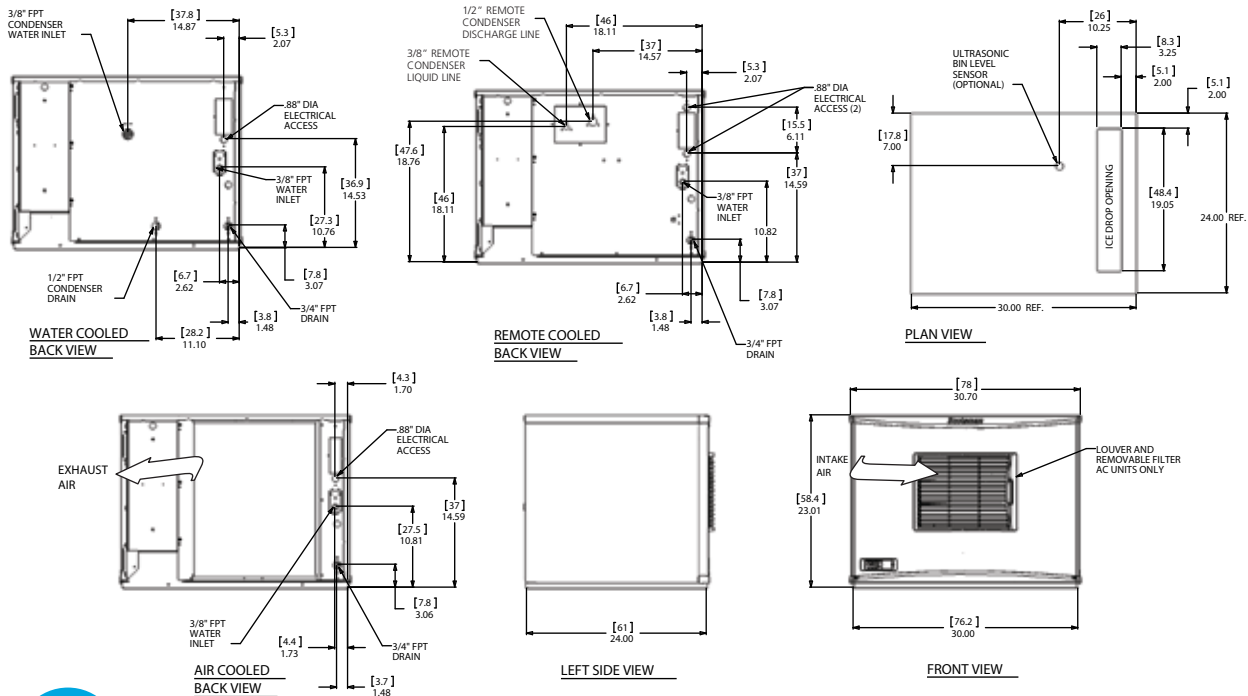

Specifications

Model Number	Condenser Unit	Basic Electrical Volts/Hz/Phase	Max. Fuse Size or HACR Circuit Breaker (amps)	Circuit Wires	Min. Circuit Ampacity	Energy Consumption kWh/100 lb (45.4 kg) 90°F(32°C)/70°F(21°C)	Water Usage Gallons/100 lb (liters/45.4 kg)		
							Potable 90°F(32°C)/70°F(21°C)	Condenser 90°F(32°C)/70°F(21°C)	
Cube Size: medium or small									
med.	C0530MA-1	Air	115/60/1	20	2	15.2	5.80	18.0/68.1	-
	C0530MR-1	Remote	115/60/1	20	2	16.2	6.50	18.0/68.1	-
	C0530MW-1	Water	115/60/1	15	2	13.5	5.00	18.0/68.1	160.0/606.7
	C0530MA-32	Air	208-230/60/1	15	2	7.8	5.80	18.0/68.1	-
sm.	C0530SA-1	Air	115/60/1	20	2	15.2	5.80	18.0/68.1	-
	C0530SR-1	Remote	115/60/1	20	2	16.2	6.50	18.0/68.1	-
	C0530SW-1	Water	115/60/1	15	2	13.5	5.00	18.0/68.1	160.0/606.7
	C0530SA-32	Air	208-230/60/1	15	2	7.8	5.80	18.0/68.1	-



All Models

Dimensions (W x D x H):

Unit: 30" x 24" x 23"
(76.2 x 61.0 x 58.4 cm)

Shipping Carton: 33.5" x 27.5" x 28"
(85.1 x 69.9 x 71.1 cm)

Shipping Weight: 175 lb / 80 kg

BTUs per hour: 7,900

Refrigerant: R-404A



Accessories

Model Number	Description
KVS	Vari-Smart™ Ice Level Control - Program ice bin levels to match ice needs.
KSBU	Smart-Board™ Advanced Control - Use additional operational data for fast diagnosis.
KSBU-N	Smart-Board™ Advanced Control with Network - Network capable.
ERC111-1	Remote condenser for C0530xR, 115/60/1- Consult remote condenser spec sheet for details
BRTE10	10ft (3.0 m) line set, brazing required
BRTE25	25ft (7.6 m) line set, brazing required
BRTE40	40ft (12.2 m) line set, brazing required
BRTE75	75ft (22.9 m) line set, brazing required
KPAS	Prodigy Advanced Sustainability Kit - Includes KVS and KSBU - N
KPPSA323	Prodigy Plus® Side Air Flow Kit for C0330, C0530 and C0630

Scotsman recommends all ice machines have water filtration. See Scotsman water filter specification sheet for details.



Operating Requirements

	Minimum	Maximum
Air Temperatures	50°F (10°C)	100°F (38°C)
Water Temperatures	40°F (4.4°C)	100°F (38°C)
Remote Cond. Temps	-20°F (-29°C)	120°F (49°C)
Water Pressures	20 PSIG (1.4 bar)	80 PSIG (5.5 bar)
Electrical Voltage	-5%	+10%

Specifications and design are subject to change without notice.

C0530 - 500lb Cube Ice Machine

• 101 Corporate Woods Parkway, Vernon Hills, IL 60061 •

• 1-800-SCOTSMAN • Fax: 847-913-9844 • www.scotsman-ice.com • customer.relations@scotsman-ice.com •

© 2018 Scotsman Ice Systems.

Scotsman®

SIS-SS-PP-C0530 02-18

Scotsman®

B322S, B330P, B530P/S, B842S, B948S - Storage Bins

Modular Storage Bins



B530S show with optional KLP8S legs.

Features

- New sleek, contemporary styling. A perfect match to Prodigy Plus® cube ice machines and other Scotsman ice machines.
- Convenient, built-in scoop holder.
- Easily removable baffle, no tools required for cleaning.
- Lightweight.
- Unique recessed drain fitting for maximum installation flexibility.
- Corrosion resistant.
- Spring loaded door with hidden hinges for easy opening and closing (except for B230P).
- Available in metallic finish or durable rotocast plastic.
- Ice scoop included.



Certification



Storage Capacity

B322S	B330P	B530P/S	B842S	B948S
Application Capacity	Application Capacity	Application Capacity	Application Capacity	Application Capacity
370/168 lb/kg	344/156 lb/kg	536/244 lb/kg	778/353 lb/kg	893/406 lb/kg

Application capacity is based on 90% of total volume in cubic feet x 34 lb/ft³



Polyurethane Insulation

Foam insulation is forced between the wall and liner under heat and pressure to form a perfect wall to wall bond, preserving ice supply for long periods.



Bin Interior

The polyethylene bin interior is sanitary and easy to clean. Resists scratches and scuffs from ice scoops.



Warranty

- 3 years parts and labor on all components.
- Warranty valid in North, South & Central America for commercial installations.
- Contact factory for warranty in other regions.
- Residential Applications: 1 year parts and labor

B322S, B330P, B530P/S, B842S, B948S - Storage Bins

Scotsman®

• 101 Corporate Woods Parkway, Vernon Hills, IL 60061 •
 • 1-800-SCOTSMAN • Fax: 847-913-9844 • www.scotsman-ice.com • customer.relations@scotsman-ice.com •

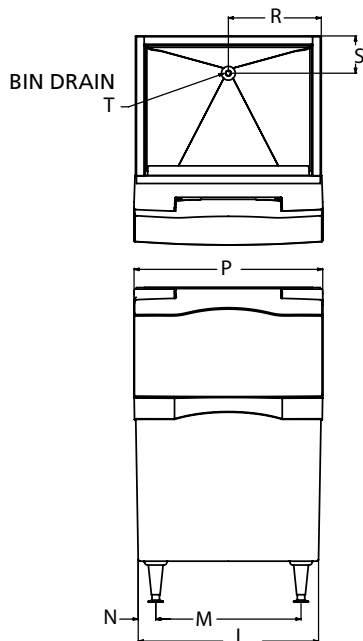

Installation Note: Allow 6" space at back for utility connections.

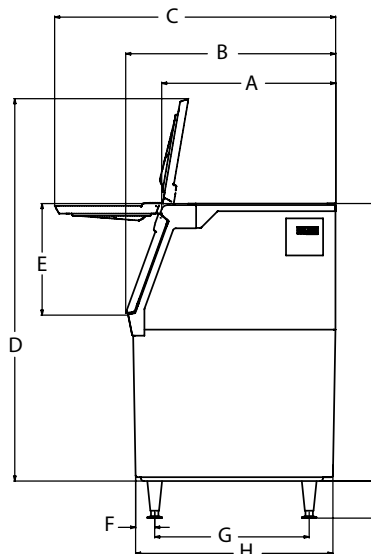

B322S, B330P, B530P/S, B842S, B948S - Storage Bins



Dimensions

Model #	A	B	C	D	E	F	G	H	J	K	L	M	N	P	R	S	T
B322S	28.23	34	45.5	61.24	18	3.88	25	32.75	44	6	22	15.5	3.25	22.5	11	6	.75 NPT
B330P	28.15	34	45.5	47.24	18	3.33	25	32.42	31	6	30	23.5	3.08	30.5	15	6	.75 NPT
B530P/S	28.15	34	45.5	61.24	18	3.09	25	31.93	44	6	30	23.5	2.83	30.5	15	6	.75 NPT
B842S	28.07	34	45.5	61.87	18	3.88	25	32.75	44	6	42	35.5	3.25	42.5	21	6	.75 NPT
B948S	28.05	34	45.5	61.24	18	3.88	25	32.75	44	6	48	41.5	3.25	48.5	24	6	.75 NPT



Overall Dimensions

Model #	Carton (W x D x H)*
B322S	22" x 34" x 44"
B330P	30" x 34" x 31"
B530P	30" x 34" x 44"
B530S	30" x 34" x 44"
B842S	42" x 34" x 44"
B948S	48" x 34" x 44"

* Add 6" Height for bin legs.



Accessories*

Model Number	Description
KBC 1	Kit, bit casters for B530S, B842S, B948S and SB380.** Not for use with B322S or SB480 when using extensions.
KBC1P	Kit, bin casters for B330P and B530P.**
KLP7	Kit, legs, 6", flanged feet, for B bins, HD dispensers, AFE, CU1/2/3 and NSE.
KLP8S	Kit, legs, 6", stainless steel, for B bins, HD dispensers, AFE, CU1/2/3 and NSE.
BGS10	Bagger, hooks on any bin.
KBAG	Kit, bags, 1000, for BGS10.
KSEALER	Kit, tape sealer, for BGS10.
KTAPE	Kit, tape, 180 ft. roll, for BGS10.
KHOLDER	Kit, scoop holder, stainless steel.

**3.5" Diameter, 2 locking, raises bin 4.5".



Shipping Information

Model #	Carton (W x D x H)	Weight (lb/kg)
B322S	26" x 36" x 49"	140/64
B330P	33" x 36" x 35"	90/41
B530P	33" x 37" x 49"	110/50
B530S	33" x 37" x 49"	150/68
B842S	45" x 36" x 49"	190/86
B948S	51" x 36" x 49"	209/95