



www.santos.fr



Just using your imagination:
create and make lots of fruit
and vegetable juices, mixtures,
coulis, sauces...

Professional Juice Extractor “Ezy-clean® system” #58



Internationally patented models



Professional Centrifugal Juice

Introducing the Santos Juicer #58

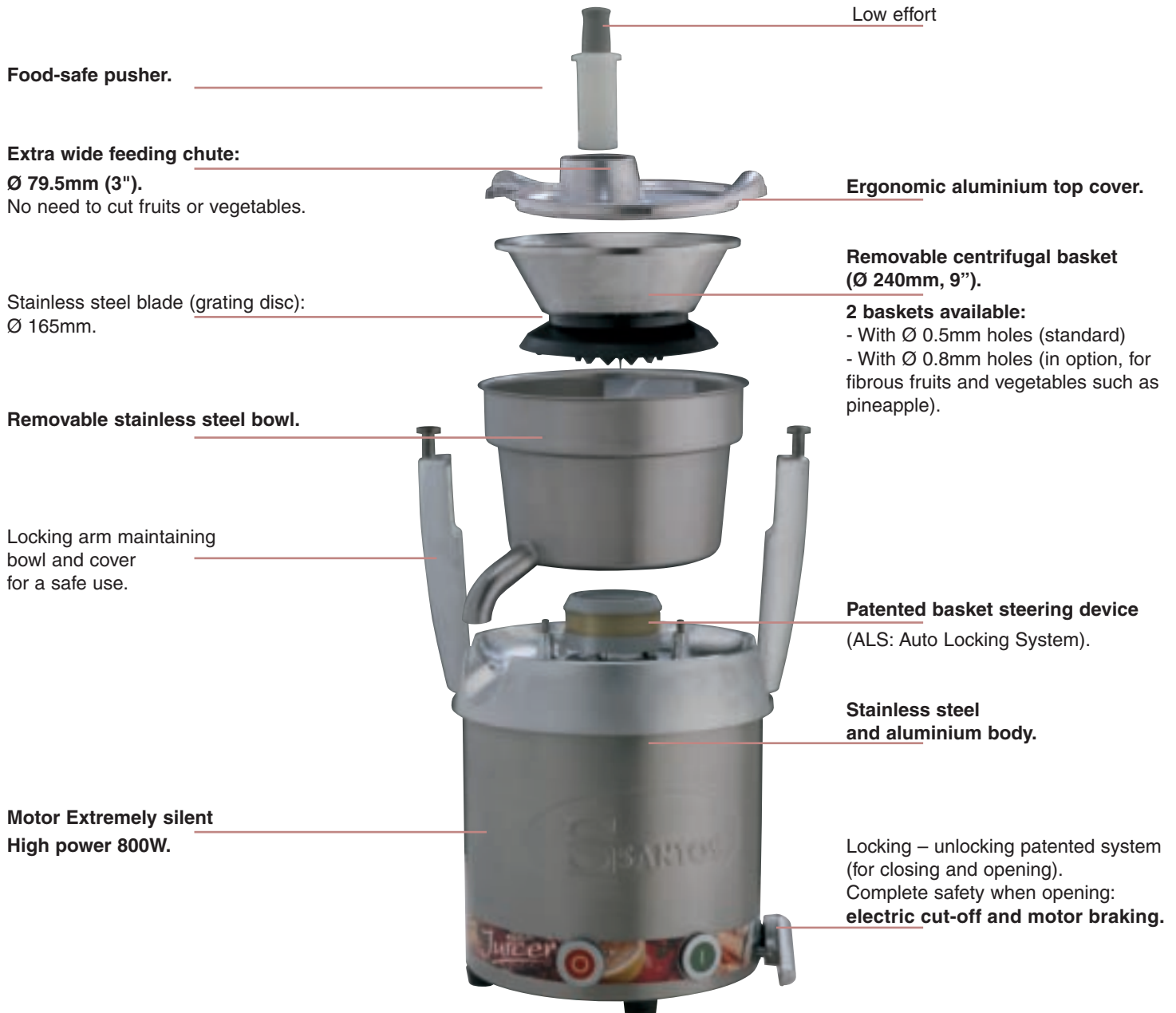

SAFETY - STANDARDS - HYGIENE

In accordance with the following regulations:

- Machinery directive 98/37/EC - 2006/42/EC
- Electromagnetic compatibility 2004/108/EC
- Electrical equipment designed for use within certain voltage limits "low voltage" 73/23/EEC
- RoHS directive 2002/95/EC
- Harmonized European standards: EN ISO 12100-1 et 2: 2004 – EN 60204-1: 2006 - EN 12547: 1998 Juice Extractor

Hygiene:

All removable parts can be put in a dishwasher or easily cleaned with hot soapy water.

Thermal safety:

Motor protected by internal thermal detector and overload protector.

TECHNICAL DATA

Technical specifications:

- **Motor :**
 - Single phase: 100-120 V – 50/60 Hz – 1300 W
 - UL. NSF**
 - 220-240 V – 50/60 Hz – 1300 W
 - CE, GS. Keti (pending)**
 - Speed: 3000 RPM (50Hz)
3600 RPM (60HZ)
- **Weight:**
 - Net: 24 Kg (53 lbs)
 - Shipping: 27 Kg (59,5 lbs)



www.santos.fr

Extractor "Ezy-clean® system" #58

Santos: worldwide leader in commercial juicers



- 1955: First household centrifugal Juicer.
- 1986: Santos Juicer #28. First NSF, UL and GS approved juicer on the market. Worldwide used in kitchens, juice bars, hotels...
- 2000: Santos Juicer #50. First small, easy to clean commercial juicer dedicated to the Worldwide juice bar market. Ezy-clean® system launch
- 2006: Santos Juicer #58. The result of 40 years worldwide experience. Powerful and easy to clean commercial juicer.

Exclusive "Ezy-clean® system": easiness, efficiency & quality



No tool needed

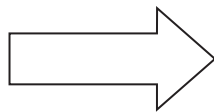

Easy to clean



Save time

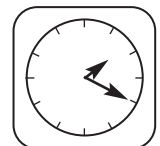

+

=

The professional centrifugal juice extractor #58 can produce pure juice with vitamins from most fruits and vegetables.

Save time and labour: no need to cut food into small pieces before juicing :

- Apples, carrots, tomatoes, cucumbers, celery, cabbage, onions, beets, pears, spinach...
- Citrus fruits : oranges, grapefruits, lemons and limes (must be peeled)
- Melons, pineapples, mangoes, kiwis, bananas (shall be peeled)
- Peaches, apricots, plums, tropical fruits (must be pitted)
- Berries: strawberries, raspberries, blackberries, blueberries...

It can produce up to 100 litres of juice per hour.

It allows you to make all fruits and vegetable juice, cocktails, fruit sauce, coulis sauce, ice cream, sorbets...

Shipping box:

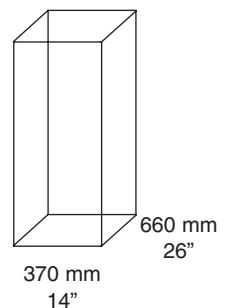

Appliance:

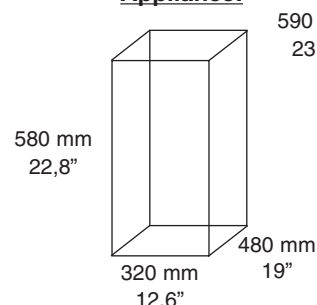

Professional centrifugal juice extractor Ezy-clean® system #58

