

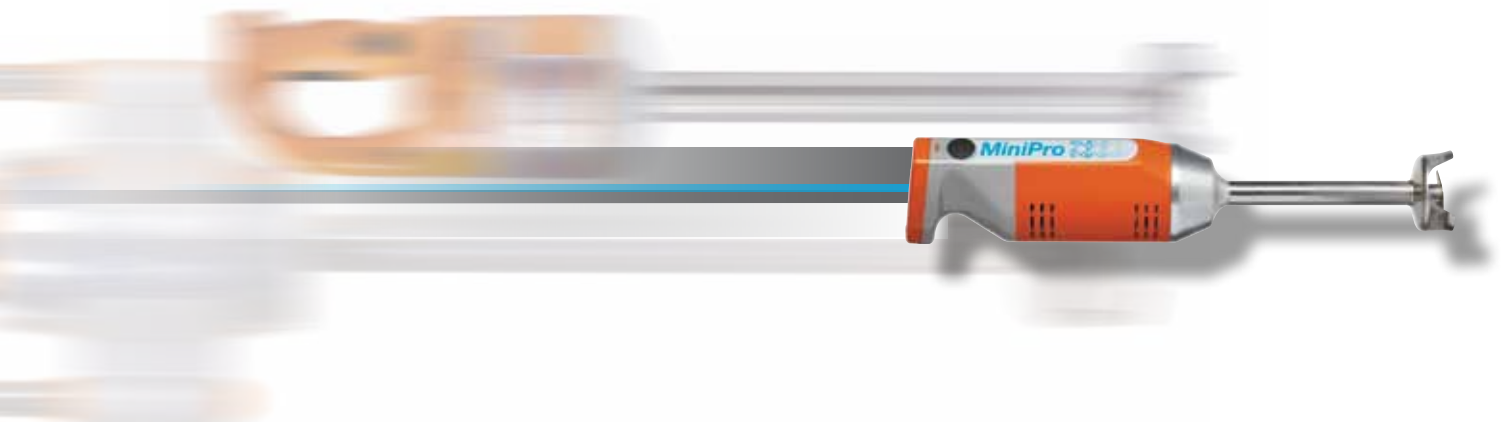

**2013-2014**  
PRODUCT CATALOG



# Demand the Best. Demand Dynamic.

## Terms and conditions

Freight Prepaid on individual orders of a minimum \$2,500 net and a flat \$50 freight charge on orders of 30 salad spinners any combination shipped to one location. (POWER PRO GIRAFFE Excluded).

Orders not meeting our Freight Prepaid criteria are F.O.B. Memphis, TN (USA) and Montreal, Que. (Canada).

Returned Goods are not accepted without the written consent of Dynamic. Merchandise must be returned within 10 days after receipt of invoice.

25% restocking charge will apply on returned merchandise. Used and or damaged merchandise and products deemed «Special Order» is non-returnable.

All products sold remain the exclusive property of Dynamic until invoice is paid in full.

No minimum orders.

To request a copy of our «Product Returns & Invoicing» Policy, please call 1 (800) 267-7794 or email us at [info@dynamicmixers.com](mailto:info@dynamicmixers.com).

## Warranty Policy

All «Electric» products include a one year «Carry in» parts and labor warranty excluding component replacements deemed as «Wear & Tear».

All «Manual» products include a one year «Limited» warranty. Component replacement requests are at the discretion of Dynamic.

Dynamic reserves the right to refuse any warranty claims resulting from product misuse and/or abuse.

## Disclaimer

Specifics contained herein with regards to product text and/or product images may change without notice.





Immersion blenders, Vegetable Cutters, Salad Spinners...  
5 generations of foodservice professionals



Specializing in quality foodservice equipment for over 50 years. Innovative and quality foodservice equipment **made exclusively in France** with a global presence in over 80 countries. The most advanced, versatile food preparation equipment for chefs and aspiring chefs.



# MINI

MINI see pages 7-8-9

01	Minipro	200 W
02	Dynashake	200 W
03	Mini Cordless Whisk	180 W
04	Mini Cordless Mixer	180 W
05	MD95	180 W
06	Minipro Motor Block	200 W
07	Minipro Mixer Tool	
08	Dynashake Mixer Tool	
09	Minipro Whisk Tool	
10	Minipro Ricer/Foodmill	
11	Minipro Processor Bowl	



0.25 / 3 gal.



0.25 / 1.25 gal.

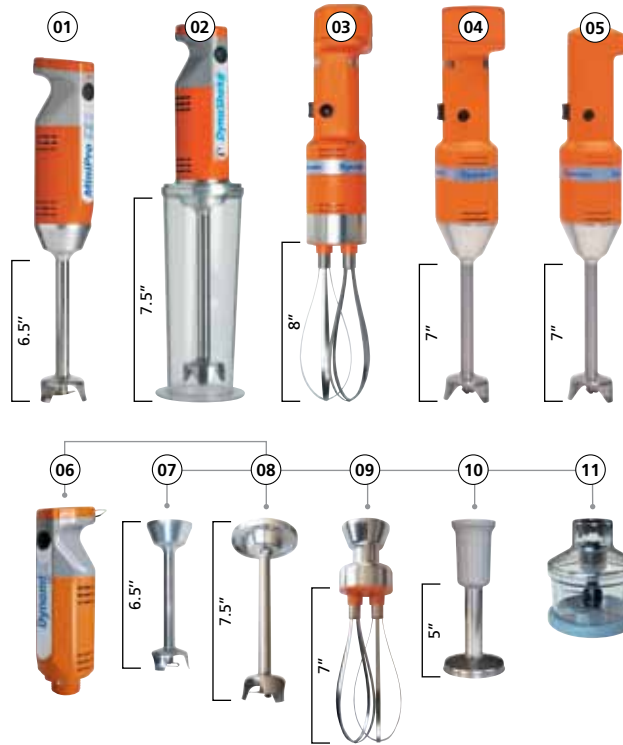

# JUNIOR

JUNIOR see pages 10-11

01	Junior Standard	200 W
02+03	Junior Plus	200 W
02+03+04	Junior Combi	200 W
02	Junior Motor Block	200 W
03	Junior Mixer Tool	
04	Junior Whisk Tool	
05	Junior Ricer/Foodmill	
06	Junior Processor Bowl	



1.25 / 6.5 gal.



0.25 / 1.25 gal.

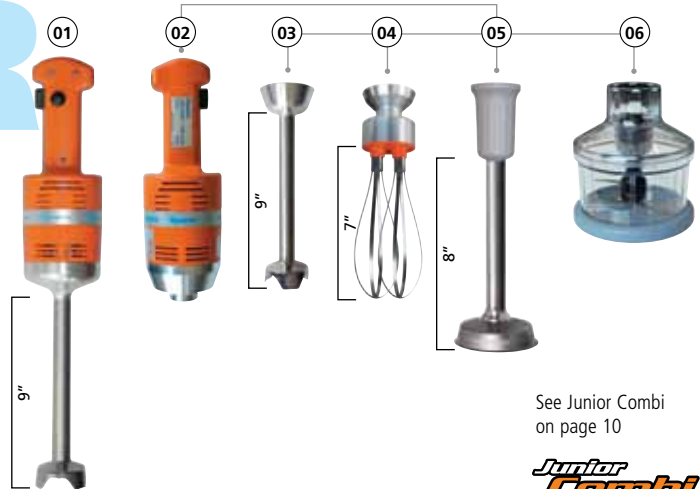

See Junior Combi on page 10

*Junior Combi*

# SENIOR

SENIOR see pages 12-13

01	PMX98	300 W
02+03	PMDH250	300 W
02+03+04	Senior Combi PMF250	300 W
02	Senior Motor Block	300 W
03	Senior Mixer Tool	
04	Senior Whisk Tool	
05	Senior Ricer/Foodmill	
06	Senior Processor Bowl	



5 / 10 gal.



1 / 5 gal.

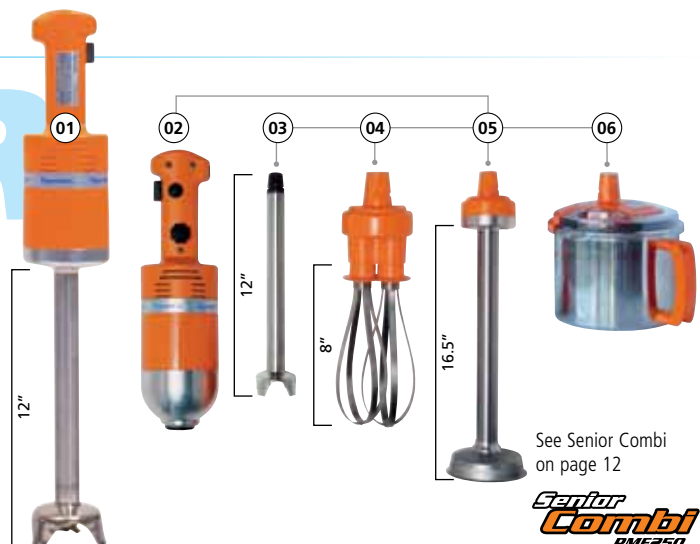

See Senior Combi on page 12

*Senior Combi PMF250*



**MASTER p.14-15-16**

01	MX91	460 W	06	F90 Whisk Tool
02	MX2000	460 W	07	FM Whip
03	MDH2000	460 W	08	AP90 Ricer/Foodmill
04	BM2000 Motor Block	460 W	09	Dynacutter Bowl
05	M90 Mixer Tool			

See Master Combi Mixers on page 15



**SMX**



**SMX see page 17**

01	SMX600E	650 W
02	SMX800E	800 W

**SPECIALTY MIXERS**



**SPECIALTY p. 18-19**

01	Junior Whisk	200 W		
02	FT97	460 W	05	MX2000DSC
03	PP97 Ricer/Foodmill	460 W	06	SMX600DSC
04	PP97 Plus	460 W	07	SMX800DSC
				650 W
				800 W

# SALAD SPINNERS

## SALAD SPINNERS p. 20

01	SD99 Manual	2.5 gal / 10 L
02	SD92 Manual	5 gal / 20 L
03	SD92SC Sealed Cover Manual	5 gal / 20 L
04	EM98 Electric	5 gal / 20 L
05	SSB1 Stabilizing Base	

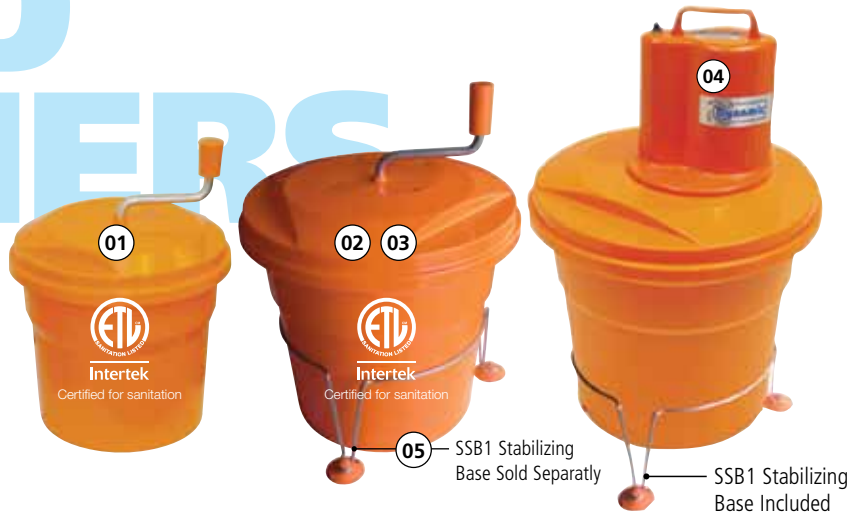

# FOOD CUTTERS

## FOOD CUTTERS see page 21

01	Dynacube Manual Dicer
02	Dynacoupe Manual Slicer/Shredder



# POWER PRO GIRAFFE

## Power Pro Giraffe see page 22

01	Power Pro «Giraffe» Mixer	1500 W
----	---------------------------	--------



25 / 75 gal.



# Minipro / Dynashake Mixers

A truly professional mixer for small preparations!

## MiniPro

The Minipro is light, quick and efficient with a detachable foot. It is the perfect mixer with 3 easily interchangeable attachments available. (see page 8 sold separately)

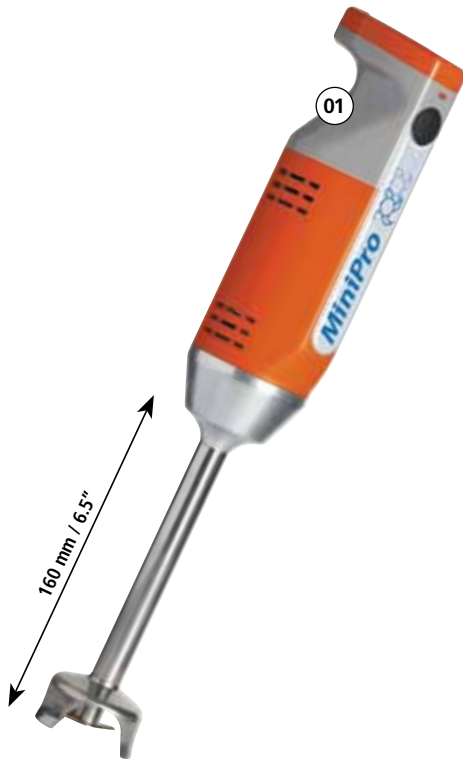

0.25 / 1 gal.



0 - 13000 R.P.M.

### 01 - Minipro detachable shaft + all blades

**MX070.1**

Minipro with all blades includes : 1 Minipro + 1 emulsifying blade + 1 standard blade + 1 batter blade + 1 dairy blade

Total length:	.....395 mm / 15,5"
Shaft length:	.....160 mm / 6,5"
Diameter:	.....70 mm / 2,8"
Actual / shipping weight:	.....0,990 Kg / 2,20 lbs
Output:	.....200 W
Speed:	.....0 to 13000 R.P.M.

### Accessories (included)



Emulsifying cutter blade



Standard cutter blade



Batter blade



Dairy blade



0.25 / 1 gal.



0 - 13000 R.P.M.

## DynaShake

The Dynashake with its detachable sealed foot to cup system allows for the perfect milkshakes, smoothies and cocktails. Standard Dynashake with all 4 cutter blades and graduated cup with cover.

### 2 - Dynashake detachable shaft + all blades + graduated cup with lid and cover

**MX054.1**

Dynashake with all blades includes: 1 Dynashake + 1 emulsifying blade + 1 standard blade + 1 beatter blade + 1 dairy blade + a 1-litre-graduated bowl + cover

Total length:	.....425 mm / 16,7"
Shaft length:	.....190 mm / 7,5"
Diameter:	.....95 mm / 3,8"
Actual / shipping weight:	.....1,4 Kg / 3 lbs
Output:	.....200 W
Speed:	.....0 to 13000 R.P.M.

### Accessories (included)



Emulsifying cutter blade



Standard cutter blade



Batter blade



Dairy blade



Graduated cup with lid

# Minipro / Dynashake Accessories



<b>01- Standard motor block</b>	<b>ACS15</b>	<b>04- Whisk tool</b> Capacity: 1-5 L Length: 185 mm - 7"	<b>ACS16</b>
<b>02- Minipro mixer tool with emulsifying blade</b> Length: 160 mm - 6.5"	<b>ACS20</b>	<b>05- Foodmill ricer</b> Capacity: 10 lbs Length: 126 mm - 5"	<b>ACS17</b>
<b>03- Dynashake mixer tool with emulsifying blade</b> Length: 190 mm - 7.5"	<b>ACS30</b>	<b>06- Minipro processor bowl</b> Capacity: 0.8 L / 1 qt.	<b>ACS18</b>
		<b>07- Graduated cup with lid</b> 1 L / 40 oz. + cover	<b>ACS10</b>



# Mini Series

Our MINI Series is light and easy to use. Standard or cordless, they are ideal for preparing small capacities of soups and sauces. Their small size offers flexibility and power for professionals at work. The MINI cordless mixers are unique products and are supplied with a charger and 2 long lasting batteries.

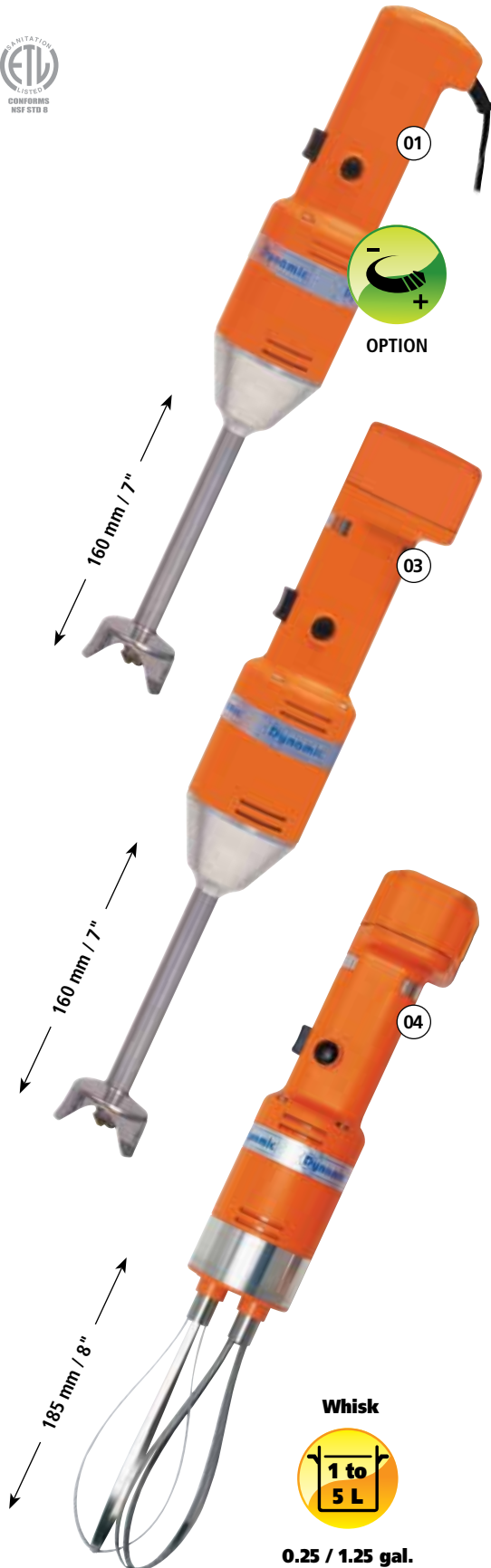

## Mixer



0.25 / 3 gal.



Emulsifying Blade - Ref. 9414  
Sold Separately



**Charger and  
2 Battery pack  
included**

<b>01- MD 95 Standard blade</b>	<b>MX010.1</b>
---------------------------------	----------------

<b>MD 95 E Emulsifying blade</b>	<b>MX008.1</b>
----------------------------------	----------------

MD 95 and MD 95 E capacity 1 to 10 litres - 0,25 / 3 gal.

Total length: .....	445 mm / 17,5"
Mixer tool length: .....	160 mm / 7"
Diameter: .....	72 mm / 3"
Actual weight / shipping weight: .....	1,2 Kg / 2,6 lbs - 1,5 Kg / 3,3 lbs
Output: .....	180 W
Speed: .....	9500 R.P.M.

<b>Option : variable speed control</b>	<b>MX010.1.V</b>
--	------------------

<b>02- Emulsifying cutter blade</b>	<b>9414</b>
-------------------------------------	-------------

<b>03- Mini cordless mixer</b>	<b>MX014.1</b>
--------------------------------	----------------

With emulsifying blade - Capacity 1 to 5 litres / 0,25 to 1,25 gal.  
2 Batteries and charger included

<b>03- Mini cordless mixer</b>	<b>MX011.1</b>
--------------------------------	----------------

With standard blade - Capacity 1 to 5 litres / 0,25 to 1,25 gal.  
2 Batteries and charger included

Total length: .....	460 mm / 18,5"
Mixer tool length: .....	160 mm / 7"
Diameter: .....	72 mm / 3"
Actual weight / shipping weight: .....	1,4 Kg / 3,0 lbs - 3,0 Kg / 6,6 lbs
Output: .....	180 W
Speed: .....	7000 R.P.M.

<b>04- Mini cordless whisk</b>	<b>FT003.1</b>
--------------------------------	----------------

Total length: .....	445 mm / 17,5"
Mixer tool length: .....	185 mm / 8"
Diameter: .....	72 mm / 3"
Actual weight / shipping weight: .....	1,5 Kg / 3,3 lbs - 3,0 Kg / 6,6 lbs
Output: .....	180 W
Speed: .....	700 R.P.M.

## Accessories

<b>05- Battery New Technology – 1hr. charge, 1hr. run time</b>	<b>AC008</b>
--	--------------

<b>06- Charger C Mini. Charger 115 V or 230 V</b>	<b>AC009.1</b>
---	----------------

# Junior Series

The JUNIOR Series is light and easy to use, with a maximum capacity of 25 litres / 6.5 gallons.

**Whisks**  
0.25 /  
1.25 gal.



**Mixer**  
1.25 /  
6.5 gal.



04



Emulsifying Blade - Ref. 4009  
Sold Separately



01 - Junior standard non-detachable	MX020.1
Total length: .....	505 mm / 20"
Mixer tool length: .....	225 mm / 9"
Diameter: .....	94 mm / 4"
Actual weight / shipping weight: .	1,7 Kg / 3,7 lbs - 2,0 Kg / 4,4 lbs
Output: .....	250 W
Speed: .....	9500 R.P.M.

**Option : variable speed control** **MX020.1.V**

02 - Junior plus detachable	MX021.1.V
Total length: .....	505 mm / 20"
Mixer tool length: .....	225 mm / 9"
Diameter: .....	94 mm / 4"
Actual weight / shipping weight: ....	1,9 Kg / 4,2 lbs - 2,3 Kg / 5 lbs
Output: .....	250 W
Speed: .....	0 to 9500 R.P.M.

03 - Junior combi detachable	MX022.1
Total length: .....	530 mm / 21"
Mixer tool length: .....	225 mm / 9"
Whisk length: .....	185 mm / 8"
Diameter: .....	94 mm / 4"
Actual weight / shipping weight: .	2,4 Kg / 5,3 lbs - 3,3 Kg / 7,3 lbs
Output: .....	250 W
Mixer / Whisk speed: .....	0 to 9500 R.P.M. / 0 to 2000 R.P.M.

**04 - Emulsifying blade** **4009**

# Junior Accessories

**Mixer** 1.25 / 6.5 gal. **Whisks** 0.25 / 1.25 gal.



**Ricer / Foodmill**

**Bowl**



<b>01- Junior motor block</b>	<b>AC100.1</b>
Total length: .....305 mm / 12" Diameter: .....94 mm / 4" Actual weight / shipping weight: ..... 1,9 Kg / 4 lbs - 2,3 Kg / 5 lbs Output: ..... 250 W Speed: ..... 0 to 9500 R.P.M.	

<b>02- Junior mixer tool</b> Capacity: 5-25 L / 1.25-6.5 gal.	<b>AC101</b>
---	--------------

<b>03- Junior whisk tool</b> Capacity: 1-5 L / 0.25-1.25 gal.	<b>AC102</b>
---	--------------

<b>04- Junior ricer/foodmill</b> Capacity: 20 lbs Length: 200 mm / 8"	<b>AC103</b>
---	--------------

<b>05- Junior processor bowl</b> Capacity: 0.8 L / 1 qt.	<b>AC104</b>
--	--------------

# Senior Series

Our SENIOR Series offers power and versatility, they are ideal for medium to large capacity recipes.



**Mixer**  
5 / 10 gal.



**Whisks**  
1 / 5 gal.



Ejectable whisks for easy cleaning.



Precise alignment of motor block and mixer tool requires only a 1/4 turn to secure.

Ref. 0880



**Convenient and secure :**  
Wall storage bracket for mixer and accessories included.



<b>01- PMIX 98 standard non-detachable</b>	<b>MX007.1</b>
Total length: .....	600 mm / 24"
Mixer tool length: .....	300 mm / 12"
Diameter: .....	.97 mm / 4"
Actual weight / shipping weight: 2,4 Kg / 5,3 lbs - 2,9 Kg / 6,4 lbs	
Output: .....	300 W
Speed: .....	9500 R.P.M.

**Option : Variable speed control** **MX007.1.V**

<b>02- PMDH 250 detachable</b>	<b>MX006.1</b>
Total length: .....	640 mm / 25"
Mixer tool length: .....	300 mm / 12"
Diameter: .....	.97 mm / 4"
Actual weight / shipping weight: 2,5 Kg / 5,5 lbs - 3,7 Kg / 8,1 lbs	
Output: .....	300 W
Speed: .....	0 to 9500 R.P.M.

<b>03- PMF 250 Senior combi</b>	<b>MF003.1</b>
Total length: .....	640 mm / 25"
Mixer tool length: .....	300 mm / 12"
Whisk length: .....	205 mm / 8"
Diameter: .....	.97 mm / 4"
Actual weight / shipping weight: 3,4 Kg / 7,5 lbs - 4,5 Kg / 9,9 lbs	
Output: .....	300 W
Mixer / Whisk Speed: .....	0 to 9500 R.P.M. - 0 to 900 R.P.M.

# Senior Accessories



**01- Senior motor block BM 250** **AC005.1**

Total length: .....330 mm / 13"  
 Diameter: .....97 mm / 4"  
 Actual weight / shipping weight: 2,0 Kg / 4,4 lbs - 3,1 Kg / 6,8 lbs  
 Output: ..... 300 W  
 Speed: ..... 0 to 9500 R.P.M.

300 watts motor block can be used with the mixer tool and whisk attachment.

**02- Senior mixer tool M 250** **AC006**  
 Capacity: 20 - 40 litres / 5 - 10 gallons

**03- Senior whisk F 250** **AC007**  
 Capacity: 5 - 10 litres / 1,25 - 2,5 gallons

**04- Senior ricer/foodmill** **AC004**  
 Capacity: 65 lbs Length: 420 mm / 16.5"

**05- Senior processor bowl** **AC055**  
 Capacity: 5 L / 6 qts

# Master Series

Our MASTER Mixer is the most advanced and versatile in the foodservice industry. Strong and dependable perfect for containers holding up to 100 litres / 25 gallons. Our wide variety of attachments adds versatility and flexibility to your food preparation needs.

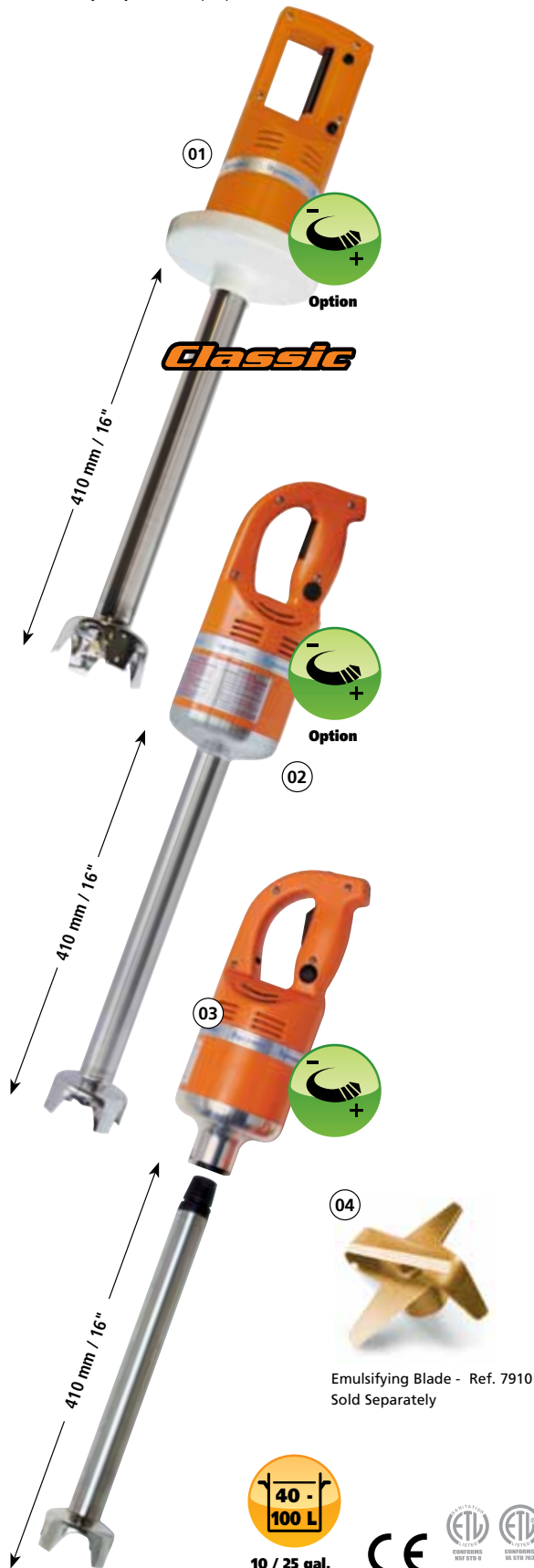

Continuous function auto run button also allows to mix continuously by pulse.



<b>01- MX 91 "Classic" non-detachable</b>	<b>MX005.1</b>
---	----------------

Total length: .....	715 mm / 28"
Mixer tool length: .....	410 mm / 16"
Diameter: .....	110 mm / 4,5"
Actual weight / shipping weight: .....	3,4 Kg / 7,5 lbs - 3,8 Kg / 8,4 lbs
Output: .....	460 W
Speed: .....	9000 R.P.M.

<b>Option : Variable speed control</b>	<b>MX005.1.V</b>
--	------------------

<b>02- MX 2000 non-detachable</b>	<b>MX004.1</b>
-----------------------------------	----------------

Total length: .....	720 mm / 28,5"
Mixer tool length: .....	410 mm / 16"
Diameter: .....	122 mm / 5"
Actual weight / shipping weight: .....	3,5 Kg / 7,7 lbs - 4,1 Kg / 9 lbs
Output: .....	460 W
Speed: .....	9500 tr/mn

<b>Option : Variable speed control</b>	<b>MX004.1.V</b>
--	------------------

<b>03- MDH 2000 Plus detachable mixer</b>	<b>MX003.1</b>
---	----------------

Total length: .....	720 mm / 30"
Mixer tool length: .....	410 mm / 16"
Diameter: .....	122 mm / 5"
Actual weight / shipping weight: .....	3,7 Kg / 8,1 lbs - 4,5 Kg / 9,9 lbs
Output: .....	460 W
Speed: .....	0 to 9500 R.P.M.

<b>04- Emulsifying cutter blade</b>	<b>7910</b>
-------------------------------------	-------------

Emulsifying Blade - Ref. 7910 Sold Separately



10 / 25 gal.



# Master Series Combi

<b>Mixer</b>  <b>10 / 25 gal.</b>	<b>Whisks</b>  <b>2.5 / 5 gal.</b>	<b>Foodmill / ricer</b>  <b>65 lbs</b>
--	---	---



**Master Combi<sup>1</sup> MF2000**

**Master Combi<sup>2</sup> MFAP2000**



Continuous function auto run button allows to mix continuously or by pulse.

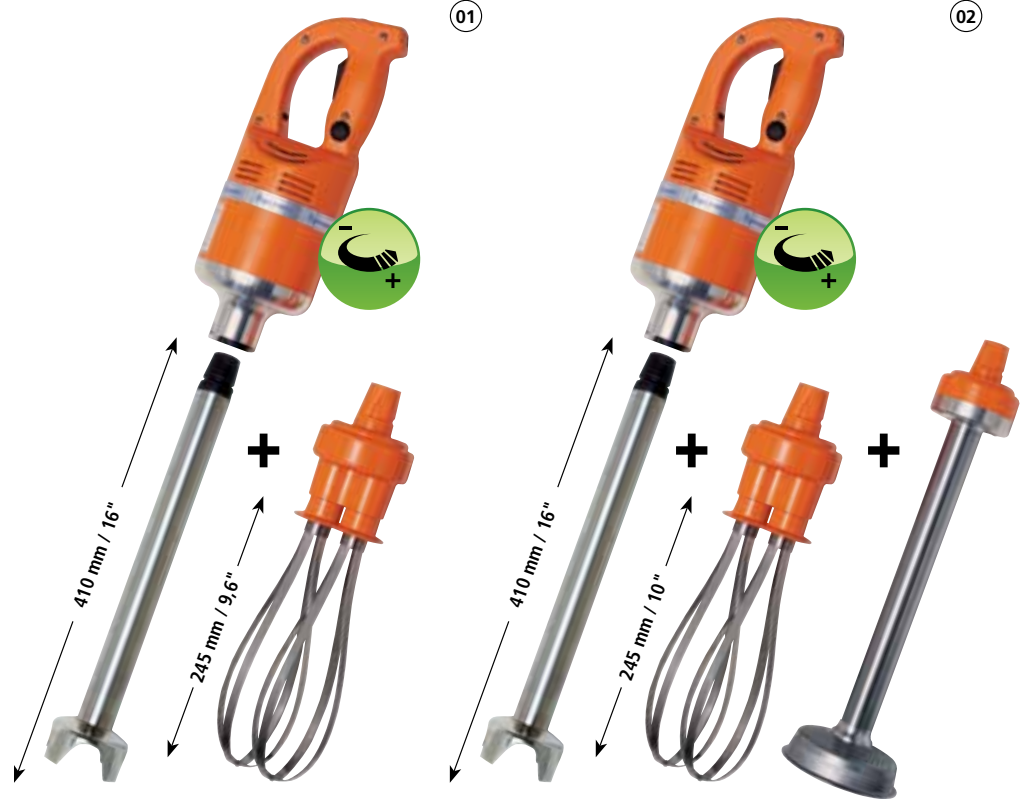

**Convenient and secure:**  
Wall storage bracket for mixer and accessories included.  
Ref. 0880



Ejectable whisks for easy cleaning.



Stainless steel perforated grid and blade can be easily dismantled for cleaning.

**01- Master combi 1 MF2000 (mixer tool + whisk)**

**MF002.1**

Total length: .....753 mm / 30"  
Mixer tool length: .....410 mm / 16"  
Whisk length: .....245 mm / 10"  
Diameter: .....122 mm / 5"  
Actual weight / shipping weight: 4,5 Kg / 9,9 lbs - 6,3 Kg / 3,9 lbs  
Output: .....460 W  
Mixer / Whisks Speed: .....0 to 9500 - 0 to 900 R.P.M.

**02- Master combi 2 MFAP 2000 detachable (mixer tool + whisk + ricer)**

**MF001.1**

Total length: .....753 mm / 30"  
Mixer tool length: .....410 mm / 16"  
Whisk length: .....245 mm / 10"  
Length and diameter of ricer / foodmill: 420 mm - 110 mm / 16,5" - 4,5"  
Diameter: .....122 mm / 5"  
Actual weight / shipping weight: 6,5 Kg / 14,3 lbs - 8,4 Kg / 18,5 lbs  
Output: .....460 W  
Mixer Speed: .....0 to 9500 R.P.M.  
Whisk Speed: .....0 to 900 R.P.M.  
Foodmill / Ricer Speed: .....0 to 600 R.P.M.

# Master Series Accessories

You can adapt multiple accessories to the BM2000 motor block. Sold separately or by Combi Package. This innovative solution simplifies your kitchen.



<b>01- BM 2000 motor block</b>	<b>AC001.1</b>	<b>04- Master whip FM 1</b>	<b>AC202</b>
Length: .....350 mm / 13,75" Diameter:.....122 mm / 4,75" Weight: .....2,7 Kg / 6,0 lbs Output: .....460 W Voltage: .....230 V or 115 V Speed: .....0 to 9500 R.P.M. with variable speed  500 watts can be used with the following attachments.		<b>05- Master whip FM 2</b>	<b>AC200</b>
<b>02- M90 Mixer tool attachment</b>	<b>AC002</b>	<b>06- Master whip FM 3</b>	<b>AC201</b>
Capacity: .....20 - 100 litres / 5 - 25 gal Length: .....420 mm / 16" Weight: .....1 Kg / 2,2 lbs		Capacity: .....20 - 200 litres / 5 - 50 gal. Length FM 1: .....420 mm / 16,5" Length FM 2: .....600 mm / 24" Length FM 3: .....700 mm / 28" Speed: .....0 to 500 R.P.M.  All stainless steel, handle support included.	
<b>03- F90 whisk attachment</b>	<b>AC003</b>	<b>07- AP 90 foodmill / ricer</b>	<b>AC004</b>
Capacity: .....5 - 20 litres / 1 - 5 gal Length: .....245 mm / 10" Weight:.....0,9 Kg / 2,0 lbs Speed: .....0 to 900 R.P.M. with variable speed		Capacity: .....30 Kg / 65 lbs Length: .....420 mm / 16,5" Diameter grid: .....110 mm / 4,3" Weight: .....1,9 Kg / 4,2 lbs Speed: .....0 to 600 R.P.M. with variable speed	
		<b>08- Dynacutter bowl complete</b>	<b>AC055</b>
		The complete Dynacutter bowl includes a 5 liters / 6 qts -bowl, cover, reducer and a standard blade or serrated blade.	



# SMX Series

Ultimate power! Our super mixers in our SMX Series, from the SMX600E to our SMX800E offers the ultimate in performance and power. Our new cooling technology ensures optimum performance.



**01- SMX600E non detachable** **MX002.1**

Total length: .....800 mm / 31,5"  
 Mixer tool length: .....530 mm / 21"  
 Diameter: .....125 mm / 5"  
 Actual weight / shipping weight: 6,1 Kg / 13,4 lbs - 7,7 Kg / 17 lbs  
 Voltage: .....115 V or 230 V  
 Output: .....650 W  
 Speed: .....9500 R.P.M.

**02- SMX800E detachable** For maintenance only **MX001.1**

Total length: .....950 mm / 37,5"  
 Mixer tool length: .....680 mm / 27"  
 Diameter: .....125 mm / 5"  
 Actual weight / shipping weight: 6,7 Kg / 14,7 lbs - 8,2 Kg / 18 lbs  
 Voltage : .....115 V or 230 V  
 Output: .....800 W  
 Speed: .....9500 R.P.M.



# Speciality Mixers



## 01- Junior whisk non-detachable

**FT005.1**

Total length: .....500 mm / 20"  
 Whisk tool length: .....185 mm / 8"  
 Diameter: .....94 mm / 4"  
 Actual weight / shipping weight: .... 1,4 Kg / 3 lbs - 1,7 Kg / 3,7 lbs  
 Output: ..... 200 W  
 Speed: ..... 0 to 2000 R.P.M.

## 02- FT 97 Master whisk non-detachable

**FT001.1**

Total length: .....650 mm / 25,5"  
 Whisk tool length: .....245 mm / 10"  
 Diameter: .....110 mm / 4,5"  
 Actual weight / shipping weight: 3,3 Kg / 7,3 lbs - 3,7 Kg / 8,1 lbs  
 Output: ..... 460 W  
 Speed: ..... 0 to 900 R.P.M.

## 03- PP 97 ricer / foodmill non detachable

**PP001.1**

## 04- PP 97 Plus ricer / foodmill detachable

**PP002.1**

Total length (PP97 / PP97+): .....870 - 920 mm / 34" - 36"  
 Mixer tool length (PP97 / PP97+): ...520 - 570 mm / 20,5" - 22,5"  
 Diameter: .....170 mm / 6,75"  
 Actual weight / shipping weight: 4,9 Kg / 10,7 lbs - 5,9 Kg / 13 lbs  
 Voltage : ..... 115 V or 230 V  
 Output: ..... 460 W  
 Speed PP97 - PP97+: ..... 0 R.P.M. - 0 to 500 R.P.M.



Stainless steel perforated grid and blade can be easily dismantled for cleaning.

## 05- FM 97 whisk tool (For PP97 Plus)

**AC208**

Length: 690 mm / 27" - Weight: 1,5 Kg / 3,3 lbs -  
 Capacity: 40 to 100 l. - comes with handle

# Speciality Mixers

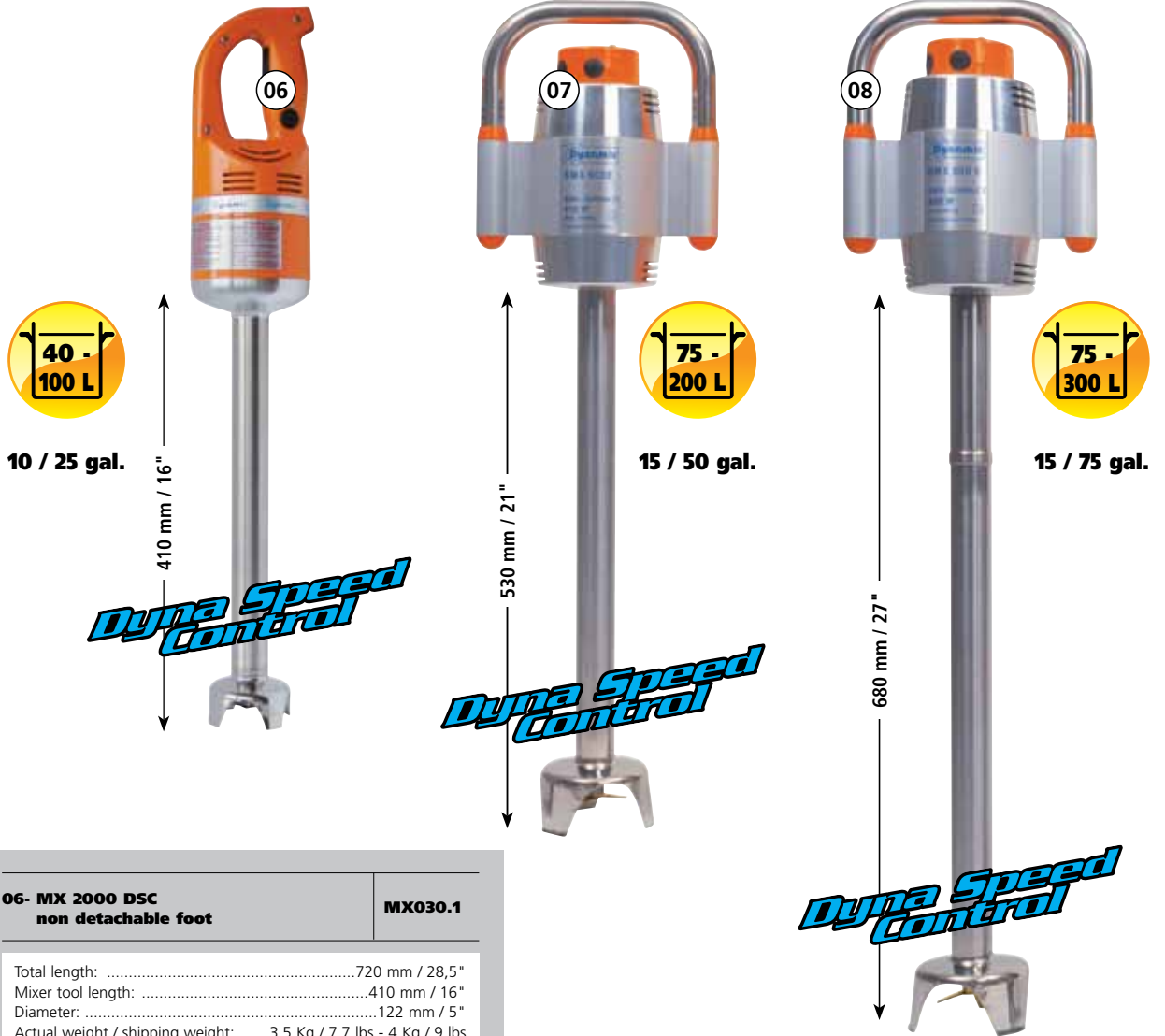

<b>06- MX 2000 DSC</b> non detachable foot	<b>MX030.1</b>
Total length: .....720 mm / 28,5" Mixer tool length: .....410 mm / 16" Diameter: .....122 mm / 5" Actual weight / shipping weight: ..... 3,5 Kg / 7,7 lbs - 4 Kg / 9 lbs Output: ..... 460 W Speed: ..... 9500 R.P.M.	
<b>07- SMX 600 DSC</b> non detachable foot	<b>MX036.1</b>
Total length: .....870 mm / 34,25" Mixer tool length: .....600 mm / 21" Diameter: .....125 mm / 5" Actual weight / shipping weight: 6,5 Kg / 14,3 lbs - 8 Kg / 17,6 lbs Voltage : ..... 115 V or 230 V Output: ..... 650 W Speed: ..... 9500 R.P.M.	
<b>08- SMX 800 DSC</b> detachable foot (For maintenance only)	<b>MX034.1</b>
Total length: .....950 mm / 37,5" Mixer tool length: .....680 mm / 27" Diameter: .....125 mm / 5" Actual weight / shipping weight: 6,7 Kg / 14,7 lbs - 8,2 Kg / 18 lbs Voltage : ..... 115 V or 230 V Output: ..... 800 W Speed: ..... 9500 R.P.M.	

## *Dyna Speed Control*

Self regulating speed - Adds longevity to all components.



9500 R.P.M.



9500 R.P.M.

# Salad Spinners

Dont be fooled by copies. Dynamic is the inventor of the commercial salad spinner. Quick and efficient, manual or electric. *Improve your food costs!*

#2815-1  
SD92/SD99  
Gear Set Kit

#2815-2  
SD92SC Sealed Cover  
Gear Set Kit

Go to our parts catalog on our website.



04) SSB1 Stabilizing Base Sold Separately



SD92SC Sealed Cover Lid



SD92 Model Shown

01- SD 99 Manual salad spinner	E001
Diameter: .....	330 mm / 13"
Total height: .....	420 mm / 18"
Actual weight / shipping weight:	2,4 Kg / 5,3 lbs - 3,1 Kg / 6,8 lbs

Suggested capacity : up to 4 heads of lettuce.

02- SD 92 Manual salad spinner	E002
Diameter: .....	430 mm / 17"
Total height: .....	500 mm / 21"
Actual weight / shipping weight:	3,6 Kg / 7,9 lbs - 4,8 Kg / 10,5 lbs

Suggested capacity : up to 8 heads of lettuce.

03- SD 92 SC manual "sealed cover"	E004
Diameter: .....	430 mm / 17"
Total height: .....	500 mm / 21"
Actual weight / shipping weight:	3,6 Kg / 7,9 lbs - 4,8 Kg / 10,5 lbs

Suggested capacity : up to 8 heads of lettuce.

04- Stabilizing base SSB1	AC019
For SD 92, SD 92 SC and EM 98	
Diameter: .....	360 mm / 14,2"
Height: .....	170 mm / 6,7"

05- EM 98 electric salad spinner	E003.1
Total height: .....	630 mm / 25"
Diameter: .....	430 mm / 17"
Actual weight / shipping weight:	8,3 Kg / 18,3 lbs - 10 Kg / 22 lbs
Voltage : .....	115 V ou 230 V
Output: .....	200 W
Speed: .....	500 R.P.M.

Suggested capacity : up to 8 heads of lettuce.

# Manual Food Cutters

The perfect manual kitchen tool. Simple and practical to use for rapidly and efficient dicing vegetables. Its safe patented grid system made with surgical stainless steel blades ensures a clean consistent cut of vegetables, fruit and cooked meats. Great for soft vegetables.

<b>01- Dynacube complete</b>	see ref. below
Includes one of the following grid set sizes.	
Blade set 7 mm x 7 mm / 1/8" (Yellow grid set with pusher)	<b>CL005</b>
Blade set 8,5 mm x 8,5 mm / 1/4" (Orange grid set with pusher)	<b>CL003</b>
Blade set 10 mm x 10 mm / 3/8" (Red grid set with pusher)	<b>CL006</b>
Blade set 14 mm x 14 mm / 1/2" (Yellow grid set with pusher)	<b>CL008</b>
Blade set 17 mm x 17 mm / 3/4" (Orange grid set with pusher)	<b>CL009</b>
<b>Additional grid sets (sold separately)</b>	see ref. below
Grid set 7 x 7mm / 1/8"	<b>AC060</b>
Grid set 8,5 x 8,5mm / 1/4"	<b>AC061</b>
Grid set 10 x 10mm / 3/8"	<b>AC062</b>
Grid set 14 x 14mm / 1/2"	<b>AC063</b>
Grid set 17 x 17mm / 3/4"	<b>AC064</b>
Total height: .....330 mm / 13"	
Diameter: .....400 mm / 15,75"	
Weight / shipping weight: .....3,1 Kg / 6,8 lbs - 4,4 Kg / 9,7 lbs	

## DYNACUBE

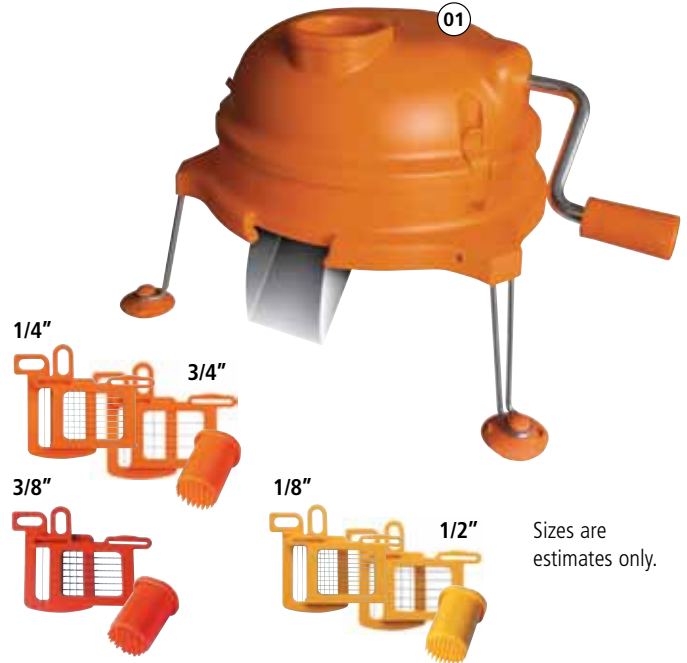

<b>02- Dynacoupe without discs</b>	<b>CL001</b>
Total height: .....260 mm / 10,25"	
Diameter: .....370 mm / 14,5"	
Actual weight / shipping weight: 2,1 Kg / 4,6 lbs - 2,8 Kg / 6,2 lbs	
Very simple and easy to use, ideal for quickly and efficiently slicing and shredding vegetables. Discs sold separately.	
<b>Dynacoupe with 2 discs</b>	<b>CL002</b>
Slicing discs: .....thickness 3 mm / 1/8"	
Shredding disc: .....holes 3 mm / 1/8"	
<b>Additional discs available</b>	
<b>02- Slicing discs</b>	
Thickness - 1,5 mm x Ø 220 mm - 1/64"	<b>AC015</b>
Thickness - 2 mm x Ø 220 mm - 5/64"	<b>AC012</b>
Thickness - 3 mm x Ø 220 mm - 1/8"	<b>AC013</b>
Thickness - 5 mm x Ø 220 mm - 3/16"	<b>AC014</b>
<b>03- Shredding discs</b>	
Ø holes - 2 mm x Ø 220 mm - 5/64"	<b>AC020</b>
Ø holes - 3 mm x Ø 220 mm - 1/8"	<b>AC021</b>
Ø holes - 4 mm x Ø 220 mm - 5/32"	<b>AC022</b>
<b>04- Storage rack</b>	<b>AC025</b>
A 6-disc-capacity storage rack.	

## DYNACOUCPE

Slice and shred with ease. The Dynacoupe is ideal for manually slicing and shredding vegetables. This unit is easy to clean and the discs are easily interchangeable.



# Power Pro Giraffe



25 / 100 gal.



0-4000 R.P.M.



## Super mixer for large capacity applications.

The Power Pro Giraffe is designed for your high volume, heavy duty mixing duties. Stainless steel construction guarantees many years of sanitary, uninterrupted food preparation. Constructed with heavy duty locking casters and tilting mechanism allows for easy transport, safe and secure operation and convenient storage.

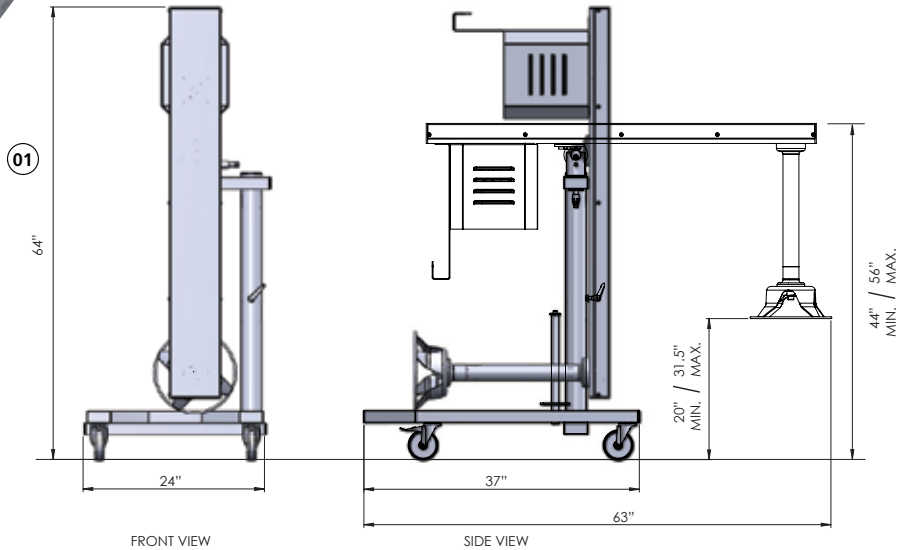

**01- Power Pro Giraffe with standard cutter blade attachment and variable speed** **TB002**

### Electrical specifications:

Voltage: ..... 230 V, 3 phase, 50/60Hz (Other voltage upon request)  
 Power output: ..... 1500 W  
 Speed : ..... 0 - 4000 R.P.M.  
 Thermal magnetic circuit breaker

**02- Whip attachment** **TB0011**

This new Power Pro Giraffe mixer whip is ideal for delicate recipes. It provides the ultimate in mixing flexibility.

## Standard cutter blade attachment

Diameter: 280mm / 11"  
 Height: 160mm / 6.5"

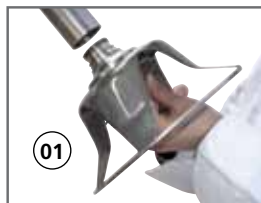

## Whip attachment (sold separately)

Diameter: 170mm / 6.5"  
 Height: 470mm / 18.5"



# Dynajucier

The PA 96 Dynajucier is quiet and sturdy. It runs at 1500 R.P.M. and is great for juicing lemons, limes, oranges and grapefruit. All easy to clean components.

Dynajucier citrus juicer	PA001.1
Total height: .....	330 mm / 13"
Diameter: .....	220 mm / 8,6"
Weight: .....	6,3 Kg / 13,9 lbs
Voltage : .....	115 V or 230 V
Output max: .....	200 W
Speed: .....	1500 R.P.M.



# Safety Cones

**Safety cones** - Trilingual : English / Spanish / French.

<b>01- BS 50 W</b>	<b>BS001</b>
Wet floor cones - Height 500 mm / 19"	
<b>02- BS 75 W</b>	<b>BS004</b>
Wet floor cones - Height 750 mm / 29,5"	



# Brackets

**Support brackets**

<b>01- SM 4 Top mounted</b>	<b>SM001</b>
Support brackets maximum dimension: .....400 mm / 16" Weight:..... 1,9 Kg / 4,2 lbs	
<b>01- SM 6 Top mounted</b>	<b>SM002</b>
Support brackets maximum dimension: .....600 mm / 24" Weight:..... 2,3 Kg / 5 lbs	
<b>01- SM 8 Top mounted</b>	<b>SM003</b>
Support brackets maximum dimension: .....800 mm / 32" Weight: ..... 2,6 Kg / 5,7 lbs	
<b>01- SM 10 Top mounted</b>	<b>SM004</b>
Support brackets maximum dimension: .....1000 mm / 40" Weight: ..... 2,8 Kg / 6,2 lbs	
<b>01- SM 12 Top mounted</b>	<b>SM005</b>
Support brackets maximum dimension : .....1200 mm / 48" Weight:..... 3,2 Kg / 7 lbs	
<b>02- SA Side mounted</b>	<b>SM006</b>
Support brackets "side mounting" Weight: ..... 0,7 Kg / 1,5 lbs	

They are easily dismantled and can be cleaned in the dishwasher. Adaptable for all series of mixers.  
Adjustable length. Practical and convenient, allows adjustable height and angle.



Used for weight assist and swivel, never leave mixer unattended.

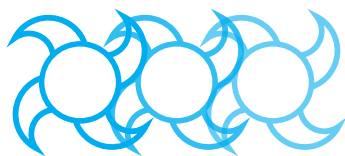

**USA      CANADA**

1320 route 9 #1352  
Champlain, NY - 12919

Phone (800) 267-7794

Fax (877) 668-6623

[info@dynamicmixers.com](mailto:info@dynamicmixers.com)

[dynamicmixersusa.com](http://dynamicmixersusa.com)

3227 Boul. Pitfield  
Montréal, Québec - H4S 1H3

Phone (514) 956-0127 / (800) 267-7794

Fax (877) 668-6623

[info@dynamicmixers.com](mailto:info@dynamicmixers.com)

[dynamicmixers.ca](http://dynamicmixers.ca)