



CGB-50NR

CGB-NR SERIES

Non-Refrigerated Curved Glass Bakery Merchandisers

MODELS

- CGB-50NR
- CGB-59NR
- CGB-77NR

FEATURES

CONSTRUCTION

- 18 gauge painted steel base
- Stainless steel on top and sides
- Three adjustable white wire shelves
- Tempered front glass tilts out for easy cleaning and loading
- Tempered glass ends
- Fluorescent top light and shelf light with T-8 bulbs

- Removable shelf lights, shelf supports and shelves
- Black trim
- White display deck
- Light switch
- Equipped with leveling legs to correct for unlevel flooring situations

DOORS

- Removable sliding rear glass doors

WARRANTY

- Standard limited one year limited parts and labor

OPTIONS

- Reflective end glass
- Reflective doors
- Non-lighted glass shelves



CGB-NR SERIES

CURVED GLASS NON-REFRIGERATED BAKERY MERCHANDISERS

TECHNICAL SPECIFICATIONS

MODEL	DIMENSIONS (in.)			DIMENSIONS (mm)			VOLTS	AMPS	NO. OF SHELVES	STANDARD SHELF SIZE (in inches)	DISPLAY AREA CU. FT.	SHIP CU. FT.	SHIP WT. (LB/KG)
	L	D	H	L	D	H							
CGB-50NR	50 ¹ / ₈	35	48 ⁷ / ₁₆	1273	889	1230	115	1.5	3	21 ³ / ₈ x 46 ⁵ / ₈ bottom & middle, 15 ³ / ₄ x 46 ⁵ / ₈ top	20.8	85.0	500/227
CGB-59NR	59 ¹ / ₈	35	48 ⁷ / ₁₆	1502	889	1230	115	1.5	3	21 ³ / ₈ x 53 ⁵ / ₈ bottom & middle, 15 ³ / ₄ x 53 ⁵ / ₈ top	24.5	95.0	560/254
CGB-77NR	77 ¹ / ₈	35	48 ⁷ / ₁₆	1959	889	1230	115	1.5	6	21 ³ / ₈ x 35 ³ / ₄ bottom & middle (2 shelves), 15 ³ / ₄ x 35 ³ / ₄ top (2 shelves)	32.0	122.5	715/324

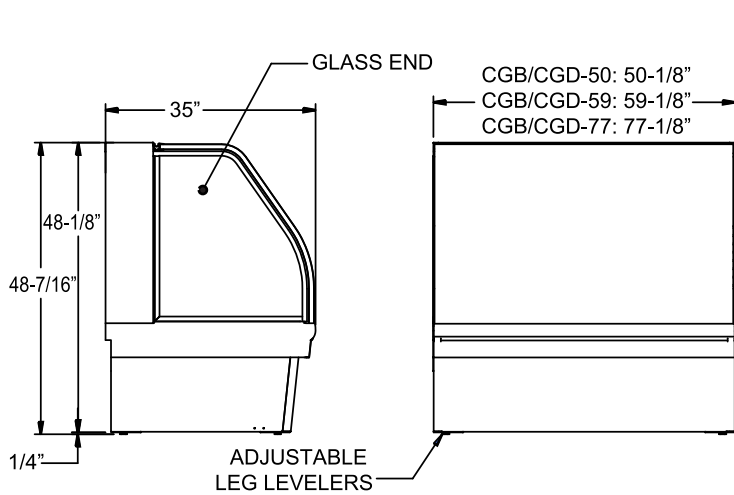

SIDE VIEW

ELEVATION VIEW

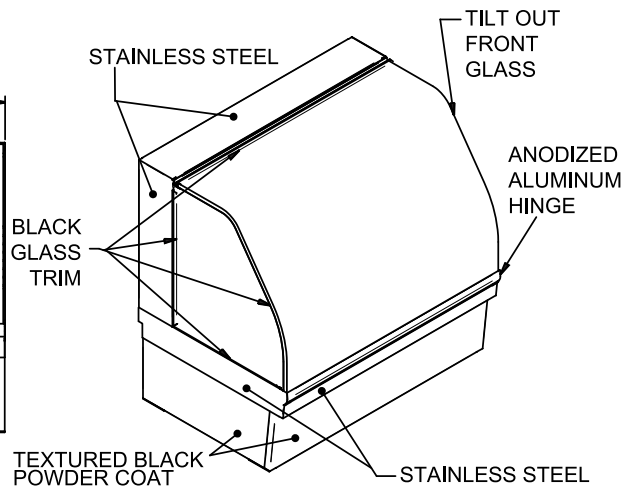

LISTINGS



ANSI/NSF 2

HOOKUP

Via plug in, 9 foot long flexible three wire 12AWG cord with molded plug.

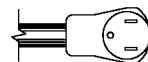

NEMA 5-15P

BID SPECIFICATIONS

Item no. CGB ____NR
Provide ____ () Curved Glass Non-Refrigerated Bakery Merchandiser(s), Master-Bilt® model no. CGB-____NR.

Merchandiser to feature painted steel base with stainless steel top and sides. The front tempered glass will tilt out. Cabinet ends will also be constructed of tempered

glass. Glass front and ends will feature black trim.

Interior lighting provided by fluorescent top and shelf lights with T8 bulbs. Three adjustable white wire shelves will also be standard. Shelf lights, shelf supports and shelves will be removable. Rear sliding glass doors will also be removable.

Other standard features will include an interior display deck, independent light switch and leveling legs.

Merchandiser to have standard limited one year limited parts and labor warranty.

Merchandiser to be UL and C-UL listed and UL-EPH classified.

NOTE: All specifications subject to change without notice.



908 Highway 15 North • New Albany, MS 38652
PHONE: 800-647-1284 or 662-534-9061 • FAX: 800-232-3966 or 662-534-6049 • www.master-bilt.com

