

MB MASTER-BILT[®]

FUSION[™] SERIES

ITEM NO. _____
 PROJECT _____
 LOCATION _____
 DATE _____ QTY. _____



MBDD59



MBDD24

Approved to NSF standard for packaged food products.

MBDD SERIES

Direct Draw Beer Coolers

MODELS

- MBDD24
- MBDD59
- MBDD69
- MBDD79
- MBDD95

FEATURES

CONSTRUCTION

- Stainless steel top
- Black finish on front, sides and back
- Galvanized steel interior with stainless steel floor
- Foamed-in-place with low ODP polyurethane insulation
- Wall thickness: 1 1/2"
- Interior LED light (except for MBDD24)
- Adjustable temperature control
- 3" diameter polished stainless steel draft towers cooled by continuous cold air circulation
- MBDD59 and MBDD69 standard with (1) 2-way gas valve, MBDD79 has (1) 3-way valve and MBDD95 has (1) 4-way valve
- Heavy-duty stainless steel threshold guard
- Standard casters on MBDD24
- Standard glass rail on MBDD24

DOORS

- Standard door locks on each door
- Magnetic door gaskets, removable without tools
- Door openings have plastic breaker strips to reduce condensation

REFRIGERATION

- Self-contained refrigeration system metered by capillary tube
- Front breathing compressor on left side
- MBDD24 model is rear breathing with internal drain, internal CO² chain harness. Other models have knockout plate for external CO² placement.
- Evaporator coils coated to resist corrosion
- Condensate evaporator
- Slide-out condensing unit for easy cleaning and service
- Rear drain connection for drip pan located in rear of compressor housing

- Refrigerant: R290
- Temperature range: 33° to 38°F (5° to 3°C)

WARRANTY

- **Standard limited three year parts and labor**
- **Additional two year coverage on compressor part**

OPTIONS

- Single, double or triple spigot towers
- 4" plate casters (casters standard on MBDD24)
- Floor protector kits

TECHNICAL SPECIFICATIONS

MODEL	DIMENSIONS (in.)			DIMENSIONS (mm)			VOLTS	AMPS	UNIT H.P.	NO. OF TOWERS	NO. OF TAPS	NO. OF KEGS***	SHIP CU. FT.	SHIP WT. (LB/KG)
	L	D*	H**	L	D	H**								
MBDD24	23 ³ / ₈	29 ¹ / ₂	55	594	749	1397	115	3.0	1/5	1 single	1	1	24.0	132/60
MBDD59	59	29 ⁵ / ₈	53	1499	752	1346	115	3.5	3/8	2 single	2	2	47.0	229/104
MBDD69	69	29 ⁵ / ₈	53	1756	752	1346	115	3.5	3/8	2 single	2	3	55.0	265/120
MBDD79	80 ⁷ / ₈	29 ⁵ / ₈	53	2051	752	1346	115	3.5	3/8	1 single, 1 double	3	4	64.0	302/137
MBDD95	95 ¹ / ₂	29 ⁵ / ₈	53	2419	752	1346	115	3.5	3/8	2 double	4	5	75.0	328/149

*Depth includes handles and rear bumpers. **Height includes draft towers ***All kegs noted are 1/2 size, 16 gallon capacity except MBDD59 which holds two 1/2 kegs and one 1/4 keg.

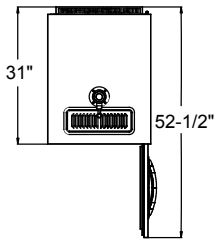

MBDD24 PLAN VIEW

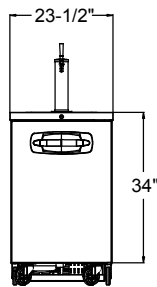

MBDD24 ELEVATION VIEW

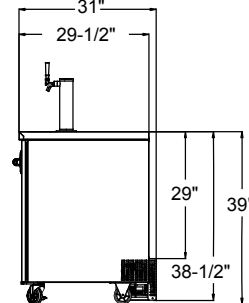

MBDD24 SIDE VIEW

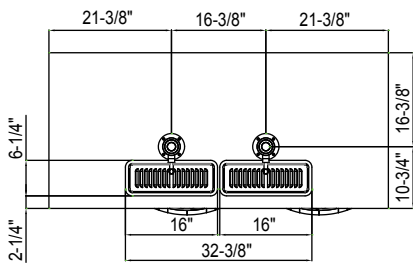

MBDD59 PLAN VIEW

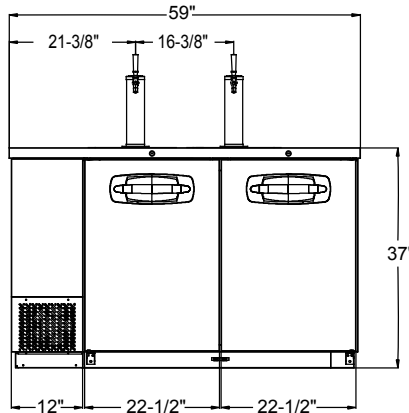

MBDD59 ELEVATION VIEW

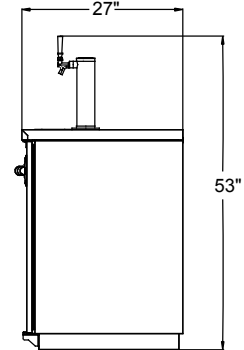

MBDD59 & MBDD69 SIDE VIEW

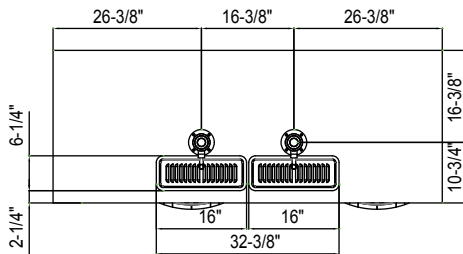

MBDD69 PLAN VIEW

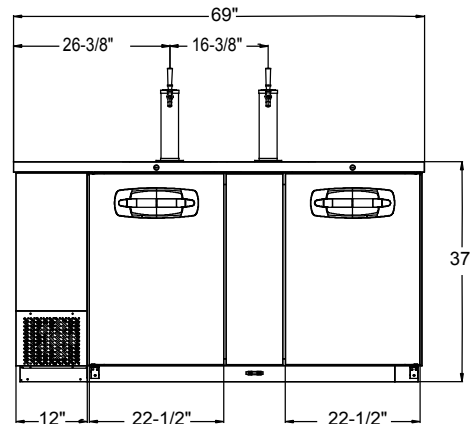

MBDD69 ELEVATION VIEW

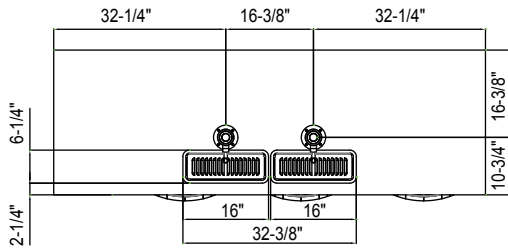

MBDD79 PLAN VIEW

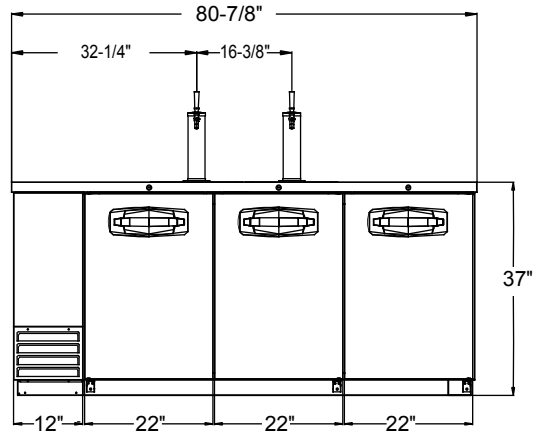

MBDD79 ELEVATION VIEW

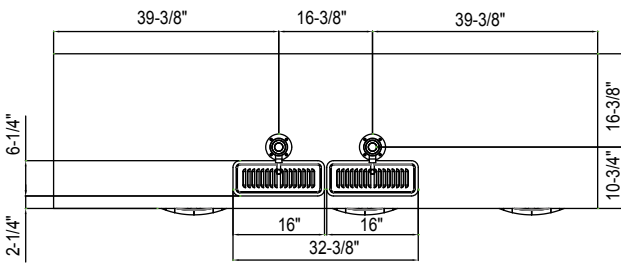

MBDD95 PLAN VIEW

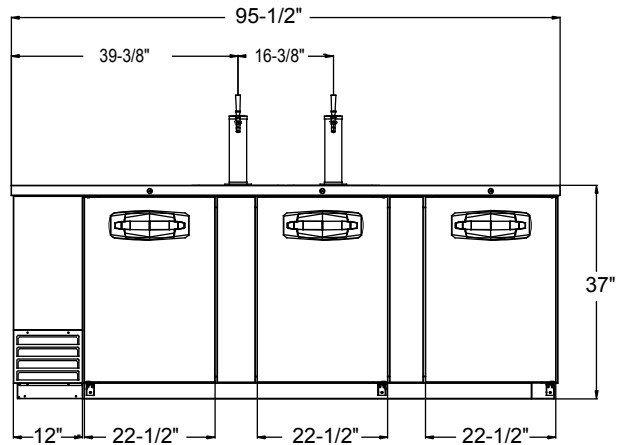

MBDD95 ELEVATION VIEW

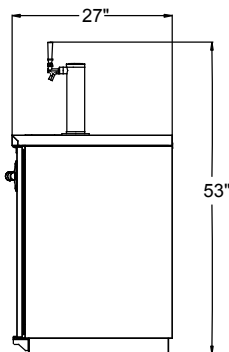

MBDD79 & MBDD95 SIDE VIEW

LISTINGS



HOOKUP

All models via plug in, 9 foot long flexible three wire 14 gauge cord with molded plug.



NEMA 5-15P

BID SPECIFICATIONS

Item no. MBDD_____.

Provide _____Direct Draw Beer Coolers, Master-Bilt® model no. MBDD_____.

Beer coolers will feature stainless steel top and black finish on front, door, sides and back. Interior will be galvanized steel with stainless steel floors. Doors will have standard locks. Door openings will have plastic breaker strips to reduce condensation. A heavy-duty stainless steel threshold guard will also be standard.

Standard three-inch diameter polished stainless steel draft towers

will be cooled by continuous cold air circulation.

MBDD59 and MBDD69 models will be standard with (1) 2-way gas valve, the MBDD79 model will have (1) 3-way valve and the MBDD95 model will have (1) 4-way valve.

The refrigeration system will be self-contained and use R290 refrigerant. The temperature range will be 33° to 38°F (.5° to 3°C). System will be equipped with coated evaporator coils and a condensate evaporator.

Condensing unit will be slide-out

type for easy cleaning and service.

MBDD24 model will be rear breathing with internal drain and internal CO² chain harness. Other models will have knockout plate for external CO² placement.

Beer cooler to have standard limited three-year parts and labor warranty with additional two-year coverage on compressor part.

Refrigerator to be UL, C-UL and ETL Sanitation listed as well as approved to NSF standard for packaged food products.

NOTE: Cabinet designed for optimum performance in air-conditioned area at 75°F ambient and 55% relative humidity. All specifications subject to change without notice.