

ITEM NO. _____
 PROJECT _____
 LOCATION _____
 DATE _____ QTY. _____



MNR/MNF SERIES Top Mounted Solid Door Reach-Ins

REFRIGERATORS

- MNR241
- MNR522
- MNR803

FREEZERS

- MNF241
- MNF522
- MNF803



FEATURES

STANDARD ELECTRONIC CONTROL

- Increases efficiency, reliability and convenience
- Allows user to easily monitor and adjust defrost functions from the panel interface on the front of the merchandiser
- Decreases service time and calls
- Eliminates cabinet thermostat, defrost timer and digital thermometer or other temperature indicator

CONSTRUCTION

- Exterior front, sides and doors are stainless steel
- Exterior top, bottom and back are galvanized steel
- All exterior joints and seams fold in without lap joints
- Interior liner and door panel are stainless steel
- 2" foamed-in-place polyurethane insulated walls

- 4" diameter casters (4 on one- and two-door models, 6 on three-door models)
- Three heavy-duty epoxy-coated shelves per section
- Interior LED lighting activated by switches for each door

DOORS

- Available with lefthand or righthand door swing
- Heavy-duty pivot hinges
- Centered key locks
- Horizontal handles
- Self-adjusting magnetic gaskets
- Freezer models have complete perimeter, anti-condensate door opening heater wires

REFRIGERATION

- Top mounted, self-contained refrigeration system
- Refrigerant: R-134a for refrigerators, R-404A for freezers
- Automatic defrost
- Automatic energy efficient hot gas condensate evaporator

- Refrigerant controlled by thermostatic expansion valve on freezers
- Minimum 4" clearance required on top, rear and sides of cabinet
- Temperature range: 34° to 41°F (1° to 5°C) for refrigerators, -5°F to 5°F (-21°C to -15°C) for freezers

WARRANTY

- **Standard limited three year parts and labor**
- **Additional two year coverage on compressor part**

OPTIONS

- Extra epoxy-coated shelves
- Extra stainless steel shelves
- Full glass doors (refrigerators only)
- Half glass doors (refrigerators only)
- Half solid doors
- Legs in lieu of casters
- Full door pan slides
- Half door pan slides
- 220/50/1 electrical

TECHNICAL SPECIFICATIONS

MODEL	DIMENSIONS (in.)			DIMENSIONS (mm)			VOLTS	AMPS	UNIT H.P.	NO. OF DOORS	NO. OF SHELVES	STANDARD SHELF SIZE (in inches)	CAP. CU. FT.	SHIP CU. FT.	SHIP WT. LB/KG
	L	D	H*	L	D	H*									
REFRIGERATORS															
MNR241	27 ¹ / ₂	35 ¹ / ₈	81 ¹ / ₂	699	892	2070	115	4.9	1/4	1	3	23L x 28D	24.0	55.2	365/166
MNR522	55	35 ¹ / ₈	81 ¹ / ₂	1397	892	2070	115	8.0	1/3	2	6	24 ¹ / ₂ L x 28D	51.9	105.3	545/248
MNR803	82 ¹ / ₂	35 ¹ / ₈	81 ¹ / ₂	2096	892	2070	115	9.1	1/2	3	9	24 ¹ / ₂ L x 28D	79.9	153.4	750/341
FREEZERS															
MNF241	27 ¹ / ₂	35 ¹ / ₈	81 ¹ / ₂	699	892	2070	115	9.7	1/2	1	3	23L x 28D	24.0	55.2	375/170
MNF522	55	35 ¹ / ₈	81 ¹ / ₂	1397	892	2070	115	13.7	3/4	2	6	24 ¹ / ₂ L x 28D	51.9	105.3	660/300
MNF803	82 ¹ / ₂	35 ¹ / ₈	81 ¹ / ₂	2096	892	2070	115	13.8	1	3	9	24 ¹ / ₂ L x 28D	79.9	153.4	805/366

*Height includes casters. With optional 6" legs overall height is 82³/₄"

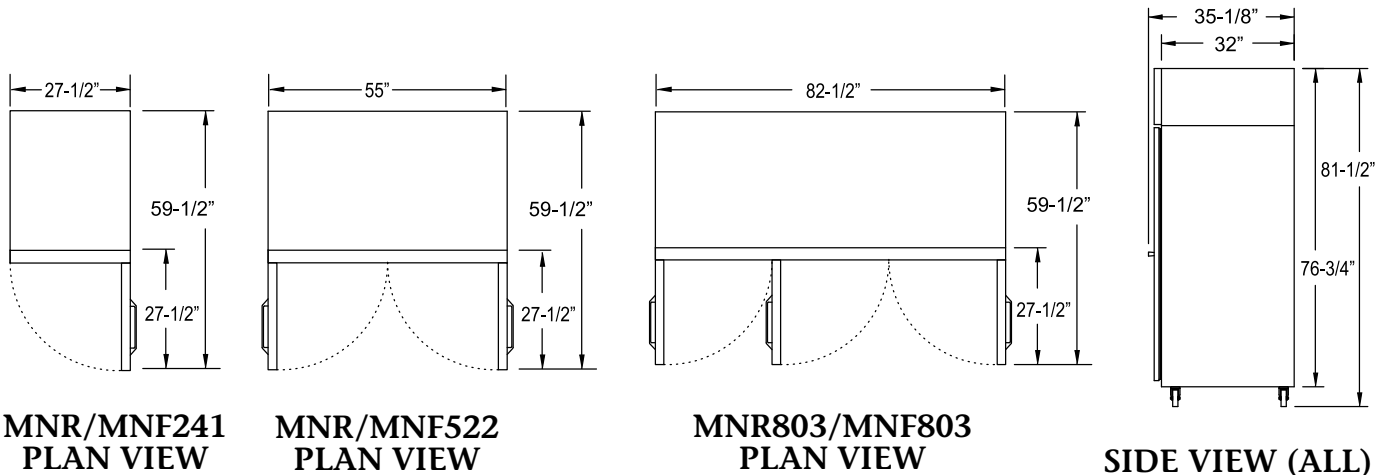

LISTINGS



HOOKUP

MNR241, MNR522, MNR803, MNF241:
Via plug in, 10 foot long flexible three wire 14/3 cord with molded plug.
MNF522, MNF803: Via plug in, 10 foot long flexible three wire 12/3 cord with molded plug.

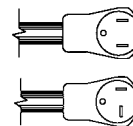

NEMA 5-15P (MNR241, MNR522, MNR803, MNF241)
NEMA 5-20P (MNF522, MNF803)

BID SPECIFICATIONS

Item no. _____
Provide _____ () Top Mounted Solid Door Reach-in(s), Master-Bilt® model no. _____.

Reach-in will be equipped with an electronically controlled monitoring system and will feature stainless steel exterior front, sides and doors. The exterior top,

bottom and back will be galvanized steel while the interior liner and door panel will be stainless steel.

The refrigeration system will be top mounted and self-contained. Freezers will use R-404A refrigerant, refrigerators will use R-134a. The temperature range will be 34° to 41°F (1° to 5°C) for refrigerators, -5°F

to 5°F (-21°C to -15°C) for freezers.

Reach-in to have standard limited three year parts and labor with additional two year coverage on compressor part.

Reach-in to be UL and C-UL listed, UL EPH classified and California Energy Code certified.

NOTE: Cabinet designed for optimum performance in air-conditioned area at 75°F ambient and 55% relative humidity. All specifications subject to change without notice.