



VOAM60-72

## VOAM-72 SERIES

### Vertical Open Air Merchandisers 72" Height

#### MODELS

- VOAM36-72
- VOAM48-72
- VOAM60-72
- VOAM72-72

### FEATURES

#### CONSTRUCTION

- Contemporary styling provides an attractive product showcase
- Standard electronic controller with these features:
  - Ability to monitor defrost functions from the front panel interface
  - Audible and visual alarm
  - Eliminates room thermostat, defrost termination/fan delay control, defrost timer and digital thermometer or other temperature indicator
- Standard LED lighting in canopy
- 24 gauge painted textured galvanized steel exterior and interior
- Standard retractable vinyl night curtain
- Stainless steel floor pans (removable for easy service)
- 2" foamed-in-place "zero ODP" urethane insulation

- Automatic defrost
- Easily accessible electrical enclosure
- Shelves adjustable in 1" increments
- Three tiers of two-position shelving with price tag molding
- Perforated interior back wall for better air flow

#### REFRIGERATION

- Refrigerant: R-404A
- Front air intake and rear air discharge
- Self-contained, bottom mount refrigeration system
- Condensing unit slides out front of case for easy cleaning and servicing
- Temp. range: 34° to 41°F (1° to 5°C)
- R-factor (insulation efficiency rating): 17.24
- Standard energy efficient automatic condensate removal system

#### WARRANTY

- **Standard limited three year parts and labor**
- **Additional two year coverage on compressor part**

#### OPTIONS

- Add suffix "R" for remote refrigeration system
- Stainless steel interior and exterior (ends, base and bumper remain black)
- LED shelf light kit
- Custom exterior colors (ends, base and bumper remain black)
- Casters
- Security cover
- Product hooks
- Condensate pump
- Higher capacity condensate evaporator pan (depending on model)

### RECOMMENDED OPERATING CONDITIONS

- Merchandisers designed to hold product in the 34° to 41°F (1° to 5°C) range
- Designed to operate in air-conditioned stores where the maximum temperature is 75°F and the maximum relative humidity is 55%
- Should not be installed in direct sunlight
- Locate cases at least:
  - 5 feet away from exterior windows
  - 10 feet away from any type of ventilation system
  - 15 feet away from exterior doors
- Bottom shelf should not be loaded such that the front air intake is obstructed
- Factory installed controls should not be altered, removed or replaced without consent of the factory
- Product must not be displayed in the cold air curtain



# VOAM-72 SERIES

## VERTICAL OPEN AIR MERCHANDISERS – 72" HEIGHT

### TECHNICAL SPECIFICATIONS

MODEL	DIMENSIONS (in.)			DIMENSIONS (mm)			VOLTS	AMPS**	UNIT H.P.	NO. OF SHELVES	STANDARD SHELF WIDTH (in inches)	CAP. CU. FT.	SHIP WT. LB/KG
	L	D	H	L	D	H							
VOAM36-72	35 1/2	34	72	902	864	1829	115	11.5	3/4	3	32 1/2	17.8	540/245
VOAM48-72	47 1/2	34	72	1207	864	1829	115	14.5	1	3	44 1/2	24.2	665/302
VOAM60-72	59 1/2	34	72	1511	864	1829	208-230*	7.8	1	6	28	30.7	790/359
VOAM72-72	71 1/2	34	72	1816	864	1829	208-230*	7.8	1	6	34	37.1	910/414

\*Note: 208-230/60/1 also requires neutral and safety ground wire. \*\*Factory installed condensate evaporator pan requires a dedicated 15 amp, 120 volt circuit.

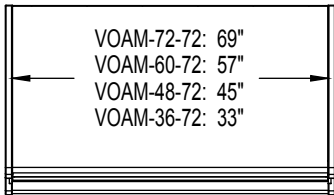

PLAN VIEW

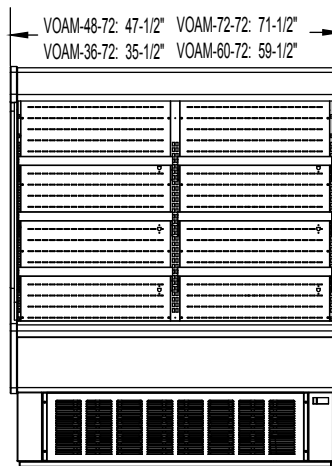

ELEVATION VIEW

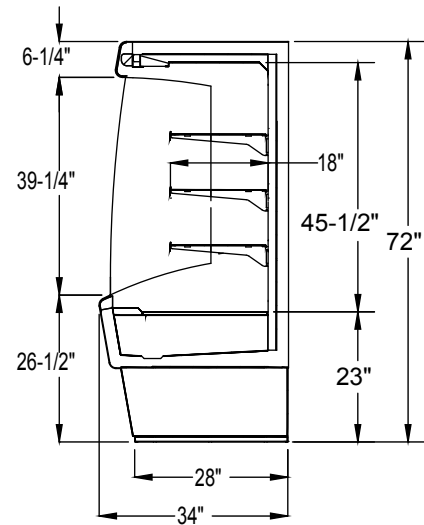

SIDE VIEW

### LISTINGS



### HOOKUP

VOAM36-72 and VOAM48-72 via plug in, 9 foot long, flexible 3 wire 14/3 cord with molded plug.

VOAM60-72 & VOAM72-72: via plug in, 9 foot long flexible four wire 208-230v 14/4 cord with neutral and ground wires and molded plug.

Condensate evaporator pan via plug in, 10 ft. long with molded plug.

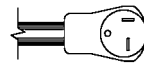

NEMA 5-20P (VOAM36-72 & VOAM48-72) - APPLIES TO U.S. MODELS ONLY, CANADIAN MODELS WILL NEED TO BE HARDWIRED.

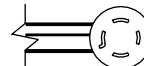

NEMA L14-20P (VOAM60-72 & VOAM72-72)

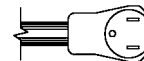

NEMA 5-15P (Condensate evaporator pan)

### BID SPECIFICATIONS

Item no. VOAM\_\_\_\_\_-72  
Provide\_\_\_\_\_( ) Vertical Open Air Merchandiser(s), Master-Bilt® model no. VOAM\_\_\_\_\_-72.

Merchandiser constructed of 24 ga. painted textured galvanized steel interior and exterior & will be equipped with an elec-

tronically controlled monitoring system.

Other features include retractable vinyl night curtain, adjustable two-position shelves, automatic defrost and 2" thick "zero ODP" polyurethane insulation.

Refrigeration system to be self-contained, have a front condenser air intake and rear air

discharge and use R-404A refrigerant. Temperature range will be 34° to 41°F (1° to 5°C).

Merchandiser to have standard limited three year parts and labor warranty with additional two year coverage on compressor part.

Merchandiser to be UL & C-UL listed and UL-EPH classified.



908 Highway 15 North • New Albany, MS 38652  
PHONE: 800-647-1284 or 662-534-9061 • FAX: 800-232-3966 or 662-534-6049 • www.master-bilt.com

All specifications subject to change without notice.