

Fresh-O-Matic® Food Steamer

Fresh-O-Matic® Food Steamer

Models

4000

4002



Standard Features

- Exclusive superheated steam
- Heavy-duty stainless steel outer wrap
- Compact, portable design
- Indicator lights - Power, Heater and Water Level
- Simple push button operation
- WearGuard® coated tray liner
- Independent top and bottom heating elements

Specifications

The Lincoln *Fresh-O-Matic* is the perfect solution for refreshing a wide variety of precooked or frozen foods. The exclusive superheated steam heats or re-heats baked goods, meats, seafood, fruits, vegetables, sandwiches, pasta and more. The *Fresh-O-Matic* is easy to install too. Simply plug it in and add distilled water - no special wiring required.

Exclusive Superheated Steam: penetrates and transfers heat faster.

Stainless Steel Construction: durable exterior is sturdy, sanitary and reliable for years of dependable service.

Compact, Portable Design: small foot print allows the unit to fit almost anywhere without sacrificing valuable counter top space.

Indicator Lights: illuminated Power, Heater and Water level indicators provide feedback to operator.

Push Button Operation: simple and easy to use with just one push of a finger.



Models

4000

4002

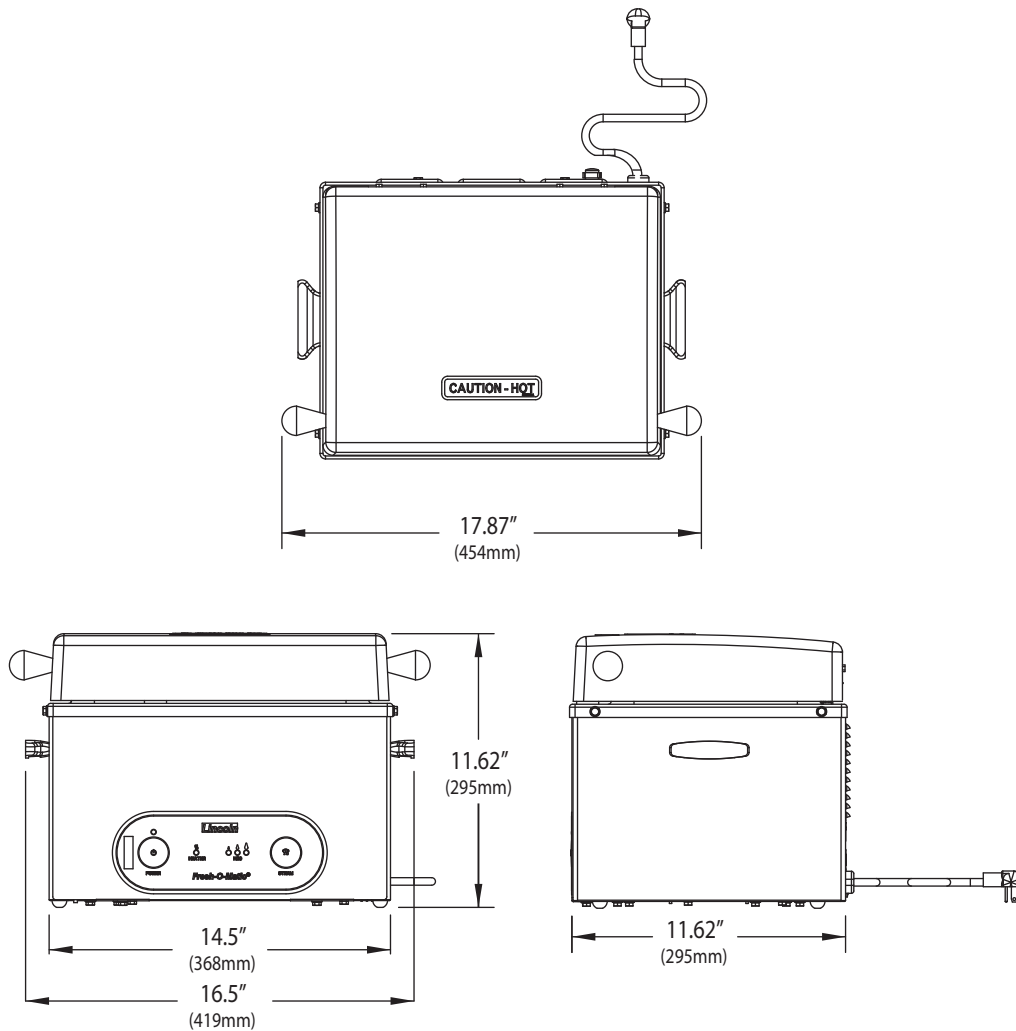

Lincoln Guarantee

Lincoln Foodservice Products, LLC guarantees the *Fresh-O-Matic* to be free from quality problems in materials and workmanship for a period of one (1) year parts and labor from the date of original purchase or fifteen (15) months from the date of manufacture. A registration card is provided with each unit. Complete all requested information and return to Lincoln Foodservice Products, LLC to insure proper warranty registration. An authorized Lincoln Foodservice Products, LLC agent must provide warranty service.

Model #	Volts	Amps	Watts	Hz	Phase	Cord Length	Plug Type
US& Canada 4000	120	12.5	1500	60	1	6'	NEMA5-15P
International 4002	220/240	5.7/6.3	1260/1500	50/60	1	6'	NEMA 5-15P

Designs and specifications subject to change without notice.

Models 4000 4002