



New STAR-MAX[®] GAS GRIDDLES WITH THERMOSTATIC CONTROLS

Models 615TF, 624TF, 636TF & 648TF

Features/Benefits:

- ★ *NEW* Throttling thermostat inserted into the griddle plate 5/16" from the cooking surface, adjusts from 150° to 450°F providing quick response to surface temperature change.
- ★ Available in 15", 24", 36" and 48" widths to meet your space and volume requirements.
- ★ *NEW* highly polished 1" thick polished steel plate for superior heat distribution, fast recovery and energy efficient operation.
- ★ All stainless steel construction and front panel for long lasting attractive appearance and ease of cleaning.
- ★ *NEW* longer lasting, heavy-duty metal knobs.
- ★ *NEW* custom designed 28,300 BTU aluminized U-shaped steel burner every 12" of cooking surface provide even heat distribution.
- ★ Double wall construction and enclosed bottom helps reduce heat loss.
- ★ Heavy-duty all-welded body construction with stainless steel front, bull nose and 4-1/2" high tapered splash guard.
- ★ Cool-to-the-touch stainless steel bull nose front provides knob protection and comfortable work zone.
- ★ Spatula wide 3-1/4" front grease trough and grease chute for easy cleaning.
- ★ Large 4-1/2 quart stainless steel grease drawer.
- ★ Gas convertible in the field conversion kit supplied. Units are shipped Natural Gas.
- ★ Heavy-duty 4" adjustable legs to fit your countertop line-up requirements.



Model 636TF

Applications:

Star-Max[®] thermostatically controlled griddles provide maximum cooking performance and reliability. Breakfast, lunch or dinner, Star has a griddle to fit your menu needs.

Quality Construction:

Star-Max[®] griddles feature 1" thick polished steel griddle plate with 4-1/2" high wrap-around stainless steel splash guard and 3-1/4" wide front access grease trough with 4-1/2 quart grease drawer capacity. Includes a 28,300 BTU aluminized burner every 12" of width controlled by a throttling thermostat, 3/4" N.P.T. male gas connection with convertible pressure regulator, and 4" adjustable legs. These units are approved for installation within 6" of non-combustible surfaces. Griddles operate on Natural or Propane gas.

New

Warranty:

Star-Max[®] gas griddles are covered by Star's **TWO YEAR** parts and labor warranty.



Star-Max[®] Gas Griddles with Thermostatic Controls



Star Manufacturing

Star-Max® Gas Griddle with Thermostatic Controls

New **STAR-MAX® GAS GRIDDLES WITH THERMOSTATIC CONTROLS**
Models 615TF, 624TF, 636TF & 648TF

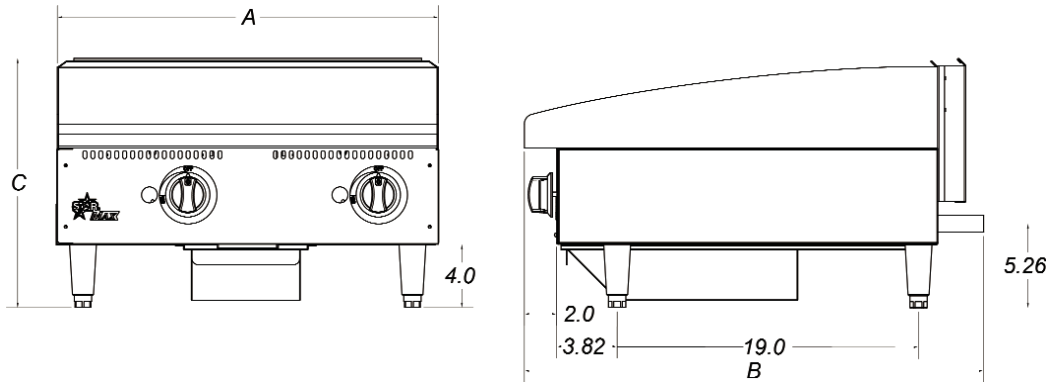

Specifications

Model No.	Dimensions			Number of Thermostats	BTU	Grid Area	Plate Thickness Inches (cm)	Weight	
	(A) Width Inches (cm)	(B) Depth Inches (cm)	(C) Height Inches (cm)					Installed lbs. (kg)	Shipping lbs. (kg)
615TF	15 (38.1)	29 (73.7)	15-1/2 (39.4)	1	28,300	304 sq. in. 1961.4 sq cm	1 (2.5)	83 (37.7)	90 (40.8)
624TF	24 (61.0)	29 (73.7)	15-1/2 (39.4)	2	56,600	498 sq. in. 3213.1 sq cm	1 (2.5)	165 (74.8)	175 (79.4)
636TF	36 (91.4)	29 (73.7)	15-1/2 (39.4)	3	84,900	747 sq. in. 4819.6 sq cm	1 (2.5)	247 (112.0)	262 (118.8)
648TF	48 (121.9)	29 (73.7)	15-1/2 (39.4)	4	113,200	996 sq. in. 6426.2 sq cm	1 (2.5)	330 (149.7)	350 (159.0)

Typical Specifications

Gas griddles are constructed with stainless steel front panel and double wall aluminized steel side panels. Griddle plate is 1" thick highly polished steel plate with 4-1/2" high tapered wrap-around stainless steel splash guard. Unit has a 3-1/4" (8.3 cm) wide front grease trough with grease chute and a 4-1/2 qt. (4.26 L) stainless steel grease drawer. Unit has a 28,300 BTU aluminized steel burner for every 12" (30.5 cm) of width and is controlled by a throttling type thermostat inserted into the griddle plate 5/16" from the cooking surface. Thermostat knobs are protected by stainless steel bull nose front. A standing pilot is provided. Griddles are supplied with 4" (10.2 cm) high die cast nickel plated steel legs that have a 1-3/8" (3.5 cm) adjustment. Gas connection is 3/4" N.P.T. male and a convertible pressure regulator is provided. Units are approved for installation within 6" (15.2 cm) of combustible and non-combustible surfaces and are UL Gas Certified and UL Sanitation listed to NSF Standard 4 Listed. Printed in the U.S.A.

Due to periodic changes in designs, methods, procedures, policies and regulations, the specifications contained in this sheet are subject to change without notice. While Star Manufacturing exercises good faith efforts to provide information that is accurate, we are not responsible for errors or omissions in information provided or conclusions reached as a result of using the specifications. By using the information provided, the user assumes all risks in connection with such use.

Star Manufacturing - 10 Sunnen Drive - P.O. Box 430129 - St. Louis, MO 63143-3800
 Phone: (314) 678-6303 - FAX: (314) 781-5445 - www.star-mfg.com