



ULTRA-MAX® THROTTLING THERMOSTAT GAS GRIDDLES

Models 824T, 836T, 848T, 860T & 872T

Features/Benefits:

- ★ Thermostatically controlled with a throttling thermostat control from 150° to 450°F provides accurate temperature control of +/- 20 degrees of set point.
- ★ Unique internal plate sensor accurately measures the temperature of the griddle plate 3/16" from the cooking surface for instant response to surface temperature change and fast recovery.
- ★ Available in 24", 36", 48", 60" and 72" widths to meet your space and volume requirements.
- ★ Ultra-Max high capacity 24" deep cooking surface is ideal for high volume operations.
- ★ Highly polished 1" thick steel plate for superior heat distribution, fast recovery and energy efficient operation.
- ★ Custom designed steel 30,000 BTU burner every 12" of cooking surface provides superior cooking performance.
- ★ Heavy-duty construction with all-weld body construction and stainless steel front, side panels, bull nose and splash guard.
- ★ "Euro-style" design with stylishly curved, ergonomically advanced front panel providing easy access and viewing of controls.
- ★ Standing pilot light for consistent performance.
- ★ Spatula wide 3-1/2" front grease trough and grease chute for easier cleaning.
- ★ Large 6 quart stainless steel grease drawer (2 drawers on 50" and 72" models).
- ★ Extra-heavy 4" adjustable legs to fit your countertop needs.
- ★ Floor model stands available for free standing unit. Optional casters available.



848T



836T

Shown with Optional Floor Stand

Applications:

Ultra-Max Throttling Thermostat gas Griddles will exceed your food service operations expectations. Designed for high performance and reliability. Ultra-Max griddles will provide years of trouble free operations.

Construction:

Ultra-Max thermostatically controlled griddles feature 1" thick highly polished steel griddle plate with 5" tapered stainless steel splash guard and 3-1/2" wide front access grease trough with 6 quart grease drawer capacity. Includes a 30,000 BTU aluminized burner every 12" of width controlled by throttling control valve with standing pilot light, 3/4" N.P.T. male gas connection with convertible pressure regulator, and 4" adjustable legs.

Warranty:

Ultra-Max gas griddles are covered by Star's one year parts and labor warranty.



Ultra-Max® Throttling Thermostat Gas Griddles



Star Manufacturing International, Inc.

Ultra-Max® Throttling Thermostat Gas Griddles

ULTRA-MAX® THROTTLING THERMOSTAT GAS GRIDDLES

Models 824T, 836T, 848T, 860T & 872T

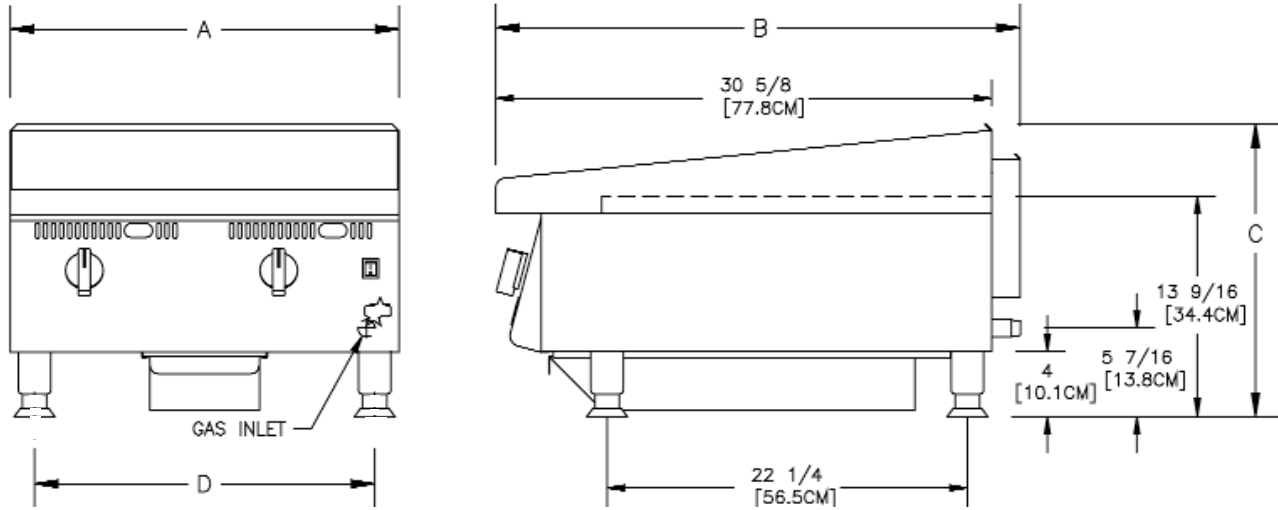

Specifications

Model No.	Dimensions				No. Controls	BTU	Grid Area	Plate Thickness	Approximate Weight	
	(A) Width Inches	(B) Depth Inches	(C) Height Inches	(D) Leg Width Inches					Installed	Shipping
824T	24" (61 cm)	32-3/8" (82.2 cm)	18" (45.7 cm)	21" (53.34)	2	60,000	573 sq. in. (3,697sq cm)	1" (2.54 cm)	220 lbs. (99.7 kg)	246 lbs. (111.5 kg)
836T	36" (91.4 cm)	32-3/8" (82.2 cm)	18" (45.7 cm)	33" (83.8)	3	90,000	860 sq. in. (5,545 sq cm)	1" (2.54 cm)	330 lbs. (149.5 kg)	369 lbs. (167.2 kg)
848T	48" (121.9cm)	32-3/8" (82.2 cm)	18" (45.7 cm)	45" (114.3)	4	120,000	1146 sq. in. (7,394 sq cm)	1" (2.54 cm)	440 lbs. (199.4 kg)	492 lbs. (222.9 kg)
860T	60" (152.4 cm)	32-3/8" (82.2 cm)	18" (45.7 cm)	57" (144.78)	5	150,000	1433 sq. in. (9,242 sq cm)	1" (2.54 cm)	550 lbs. (249.2 kg)	615 lbs. (278.7 kg)
872T	72" (182.9 cm)	32-3/8" (82.2 cm)	18" (45.7 cm)	69" (175.3)	6	180,000	1719 sq. in. (11,091 sq cm)	1" (2.54 cm)	660 lbs. (299.0 kg)	738 lbs. (334.4 kg)

Typical Specifications

Gas griddles are constructed of stainless steel, valve knobs are protected by a stainless steel bull nose front. Griddle plate is 1" (2.54 cm) thick highly polished steel plate with a 5" (12.7 cm) high tapered wrap-around stainless steel splash guard. Unit has a 3-1/2" (8.3 cm) wide front grease trough with with grease chute and a 6 qt. (5.68L) capacity stainless steel grease drawer. Models 860T and 872T house two each 6 quart grease drawers. Units are equipped with a 30,000 BTU aluminized steel burner for every 12" (30.5 cm) of width and are controlled by a throttling control valve with standing pilot light, 3/4" N.P.T. male gas connection with convertible pressure regulator. Griddles are supplied with 4" (10.2 cm) high stainless steel legs that have a 1-5/8" (4.5cm) adjustment. Units are approved for installation within 6" (15.2 cm) of combustible surfaces and are UL and CUL Classified and UL classified to NSF Standard 4 Sanitation. Printed in the U.S.A.

Due to periodic changes in designs, methods, procedures, policies and regulations, the specifications contained in this sheet are subject to change without notice. While Star Manufacturing exercises good faith efforts to provide information that is accurate, we are not responsible for errors or omissions in information provided or conclusions reached as a result of using the specifications. By using the information provided, the user assumes all risks in connection with such use.

Star Manufacturing International Inc. - 10 Sunnen Drive - P.O. Box 430129 - St. Louis, MO 63143-3800

Phone: (800) 264-7827 - FAX: (800) 264-6666 - www.star-mfg.com