



HEAT-WAVE PORTABLE WARMERS™

Models HWP-1, HWP-2, HWP-1C, HWP-2C & HWP-2CL

Features/Benefits:

- ★ Star's Heat-Wave Portable Warmers™ display your menu items while keeping them fresh and warm until served.
- ★ Self-serve display provides an open attractive look to merchandise your products and easy access from three sides.
- ★ Available with ceramic or metal sheathed elements, heated base and light options to enhance food appeal.
- ★ HWP-2's feature a swing-away top which provides easy and fast access to food pans and product.
- ★ Shipped with pan rail and 6' cord and plug. Pans can be purchased separately.

Applications:

From sandwiches to french fries, Star's Heat-Wave Portable Warmers™ will display your menu items while keeping them fresh and hot until ready to serve.

Quality Construction:

Star's Heat-Wave Portable Food Warmers™ are constructed of stainless steel and aluminum alloys. Ceramic or metal sheathed elements provide top heat. Units with a heated base include a perimeter cast-in element that is thermostatically controlled. 60 watt lights located in the top housing are optional. A 6' lead in cord and NEMA plug are standard. *Pans sold separately.*

Warranty:

Star's Heat-Wave Portable Warmers™ are covered by Star's one year parts and labor warranty.



Model HWP-2CL
shown with pan accessory



Model HWP-2



Star Manufacturing - 10 Sunnen Drive - P.O. Box 430129 - St. Louis, MO 63143-3800

Phone: (800) 264-7827 - FAX: (800) 264-6666 - www.star-mfg.com

S281/1021



HEAT-WAVE PORTABLE WARMERS™

Models HWP-1, HWP-2, HWP-1C, HWP-2C & HWP-2CL

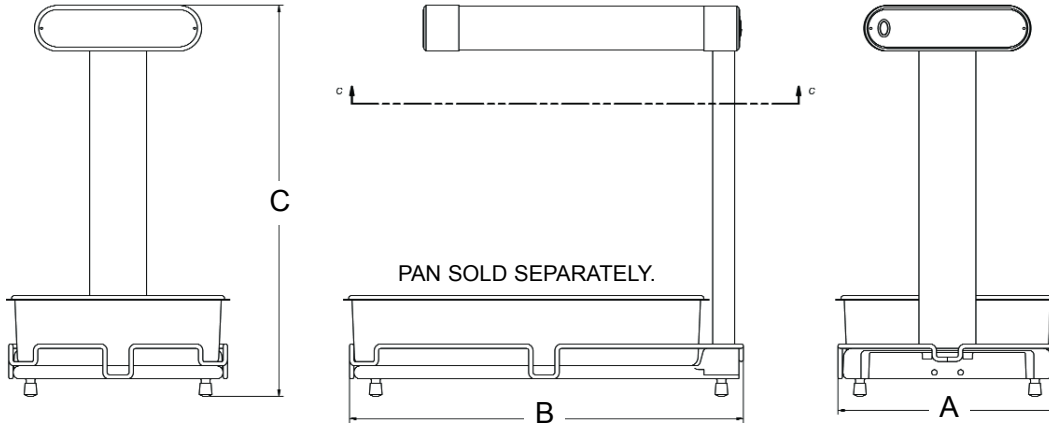

Model Specifications

MODEL NO.	(A) WIDTH (CM)	(B) DEPTH (CM)	(C) HEIGHT (CM)	VOLTAGE	WATTS	NEMA PLUG TYPE	Approximate Weight	
							SHIPPING	INSTALLED
							(LBS)	(LBS)
HWP-1	12.50" (31.75)	22.50" (57.15)	22.34" (56.75)	120V	500	5-15P	-	-
HWP-2	12.50" (31.75)	24.59" (62.46)	22.22" (56.44)	120V	750	5-15P	-	-
HWP-1C	12.50" (31.75)	22.50" (57.15)	22.34" (56.75)	120V	800	5-15P	-	-
HWP-2C	12.50" (31.75)	22.50" (57.15)	22.34" (56.75)	120V	1,050	5-15P	-	-
HWP-2CL	12.50" (31.75)	22.50" (57.15)	22.34" (56.75)	120V	1,170	5-15P	-	-

Typical Specifications

Hot food merchandisers are constructed of stainless steel, aluminum. Units are heated by incoloy sheath type elements located in the top of the unit and in the base of each shelf. Medium base incandescent lamps rated at 60 watts (120 volts) located above each shelf and controlled by an on-off switch. Units equipped with non-adjustable legs. Units to have 6 ft. (182.9 cm) lead-in cord with plug. Printed in the U.S.A.

Due to periodic changes in designs, methods, procedures, policies and regulations, the specifications contained in this sheet are subject to change without notice. While Star Manufacturing exercises good faith efforts to provide information that is accurate, we are not responsible for errors or omissions in information provided or conclusions reached as a result of using the specifications. By using the information provided, the user assumes all risks in connection with such use.

Star Manufacturing - 10 Sunnen Drive - P.O. Box 430129 - St. Louis, MO 63143-3800
Phone: (800) 264-7827 - FAX: (800) 264-6666 - www.star-mfg.com