



PERISTALTIC HEATED CONDIMENT DISPENSERS

Model SPDE1HP

Peristaltic Heated Condiment Dispensers

Features/Benefits:

- ★ Adjustable electronic temperature control for perfectly warmed product every time.
- ★ Industry first easy to read LED temperature display improves food safety.
- ★ Star's peristaltic dispenser has a unique patented heating and pumping system designed for safe and efficient dispensing of cheese or other pouched hot condiments.
- ★ Patented peristaltic pump (180RPM) design evacuates cheese directly from plastic pouch. When the pouch is empty, simply discard and easily load new pouch in seconds!
- ★ Patented forced air heating system for precise uniform temperature.
- ★ 95% plus evacuation of pouch reduces waste and saves money.
- ★ Unit dispenses up to a 160 oz. pouche
- ★ Unit operates 24/7 - No need to heat and reheat product requiring less handling of product.
- ★ Electronic portion control delivers about .9 oz. every second dispensing up to 2.7 oz. for consistent dispensing of product.
- ★ Double wall construction for quiet and cool operation.
- ★ Removable stainless steel drip tray for easy cleaning.
- ★ Lighted on/off switch for quick, easy visual confirmation of power.



Model SPDE1HP

Applications:

Star Peristaltic Dispenser dispenses delicious cheese or any other viscous product with the touch of a button. Portion control design dispenses the same amount of cheese every time you use it.

Quality Construction:

Star Peristaltic Dispenser is constructed of stainless steel side panels and door. They feature a *patented forced air* heating system for precise uniform temperature control. The patented peristaltic pump provides even flow and maintenance free operation. Dispensers come complete with a 6' cord and NEMA 5.

Warranty:

Peristaltic dispensers are covered by Star's one year parts and labor warranty.



Model SPDE1HP Open
(Cheese Not Included)





PERISTALTIC HEATED CONDIMENT DISPENSERS Model SPDE1HP

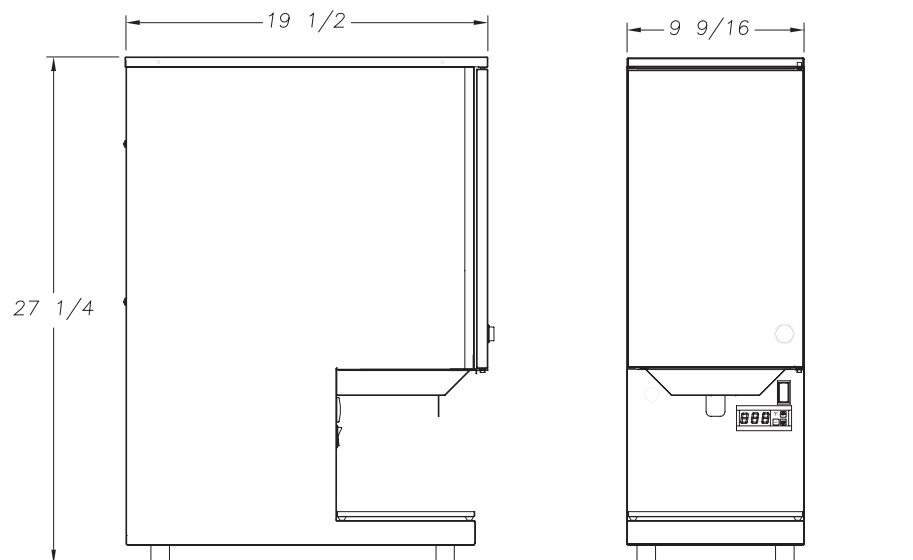

Specifications

Model	Description	Electrical					Dimensions			Approximate Weight	
		Volts	Motor	Watts	Amps	Nema Plug	(A) Width Inches (cm)	(B) Depth Inches (cm)	(C) Height Inches (cm)	Installed lbs. (kg)	Shipping lbs. (kg)
SPDE1HP	Single Hot Food Dispenser High Performance with Portion Control	120V	180RPM	750	6.75	5-15P	9-9/16 (24.1)	19-1/2 (49.8)	27-1/4 (69.2)	36 (16.34)	45 (20.43)

Typical Specifications

Patented peristaltic dispenser has stainless steel construction. Unit has adjustable temperature control and an optional adjustable portion control. Dispenser has a patented forced air heating system for precise uniform temperature. Dispenser has a 180 RPM motor for high output. Unit has a lighted on/off switch and removable stainless steel drip pan. Patented peristaltic dispensers are shipped with a 6 foot lead in cord with a molded plug NEMA 5-15P. Units are listed by UL, CUL and UL-Sanitation Classified to NSF Std. #18. U.S. Pat. No. 6,016,935. Printed in the U.S.A.