



T&S BRASS AND BRONZE WORKS, INC.

2 Saddleback Cove / P.O. Box 1088
Travelers Rest, SC 29690

Model No.

B-0830

Item No.

Travelers Rest, SC: 800-476-4103 • Simi Valley, CA: 800-423-0150 • Fax: 864-834-3518 • www.tsbrass.com

This Space for Architect/Engineer Approval

Job Name _____ Date _____

Model Specified _____ Quantity _____

Customer/Wholesaler _____

Contractor _____

Architect/Engineer _____



ADA Compliant



Furnished w/ Pop-Up
Drain Assembly

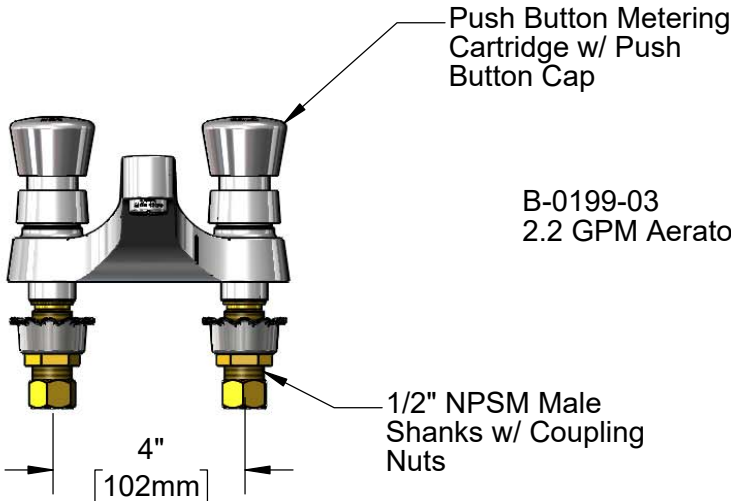
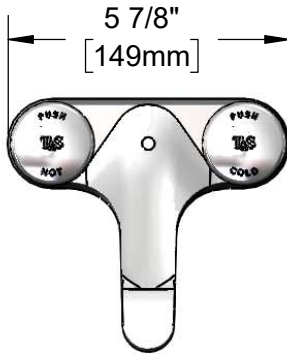

B-0199-03
2.2 GPM Aerator

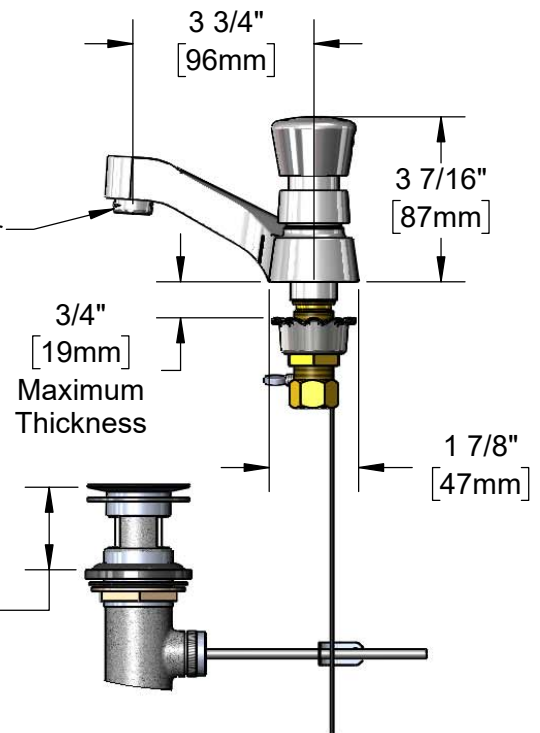

Rough-In Requirement:

Faucet: (3) 1 1/8" [29mm] Diameter Mounting Holes

Pop-Up Drain Fits Sinks with ϕ 1 7/16" [36mm] to ϕ 1 3/4" [44mm] Drain Hole

Product Specifications:

4" Centerset Deck Mount Faucet w/ Push Button Metering Cartridges, 2.2 GPM Aerator, 1/2" NPSM Male Inlets w/ Coupling Nuts and Pop-Up Drain

Product Compliance:

ASME A112.18.1 / CSA B125.1
NSF 61 - Section 9
NSF 372 (Low Lead Content)
ANSI A117.1 (ADA)

Drawn: KJG

Checked: JRM

Approved: JHB

Date: 02/18/19

Scale: 1:4

Sheet: 1 of 2



T&S BRASS AND BRONZE WORKS, INC.
 2 Saddleback Cove / P.O. Box 1088
 Travelers Rest, SC 29690

Model No.
B-0830

Item No.

Travelers Rest, SC: 800-476-4103 • Simi Valley, CA: 800-423-0150 • Fax: 864-834-3518 • www.tsbrass.com

ITEM NO.	SALES NO.	DESCRIPTION
1	014195-40	Cold Push Button Cap w/ Spanner Bit
2	238AC	Metering Cartridge w/ Cold Push Button Cap & Spanner Bit
3	001000-45	Rosette Washer
4	002954-45	Shank Lock Nut
5	000958-20	Coupling Nut
6	B-0898	Pop-Up
7	B-0199-03	2.2 GPM Aerator
8	238A	Push Button Metering Cartridge
9	014194-40	Hot Push Button Cap w/ Spanner Bit
10	238AH	Metering Cartridge w/ Hot Push Button Cap & Spanner Bit

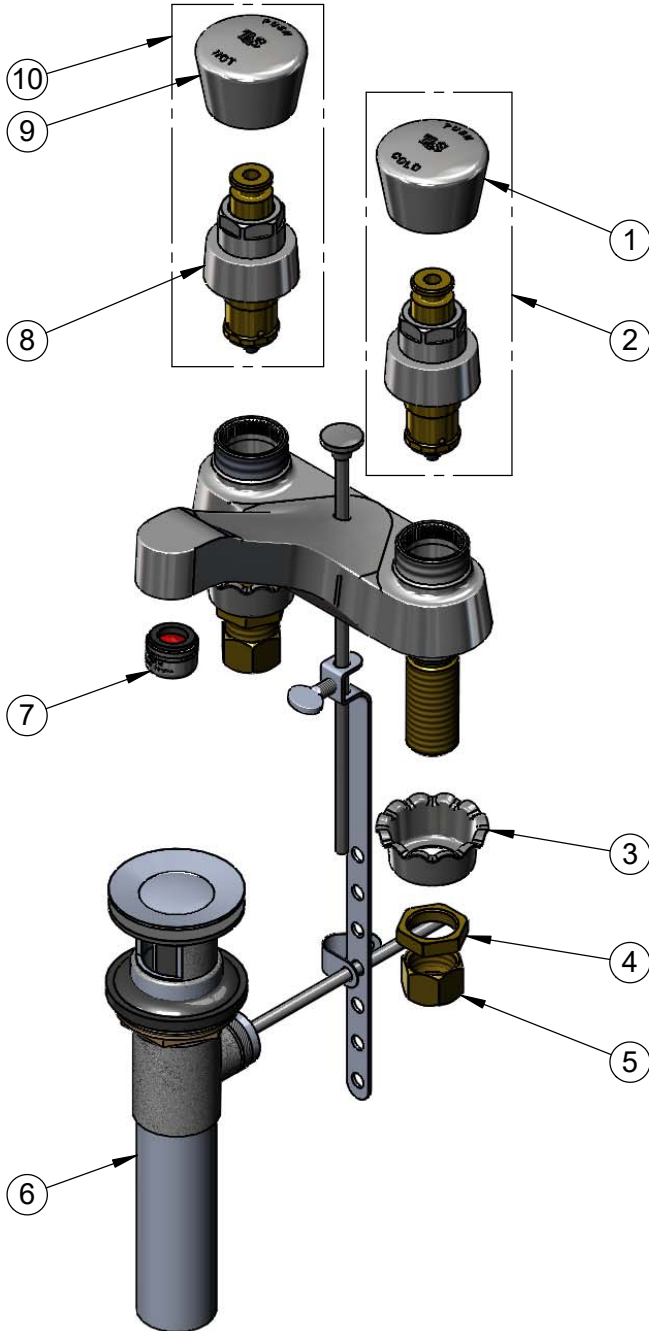

014734-45
 Spanner Bit

Product Specifications:
 4" Centerset Deck Mount Faucet w/ Push Button Metering Cartridges, 2.2 GPM Aerator, 1/2" NPSM Male Inlets w/ Coupling Nuts and Pop-Up Drain

Product Compliance:
 ASME A112.18.1 / CSA B125.1
 NSF 61 - Section 9
 NSF 372 (Low Lead Content)
 ANSI A117.1 (ADA)