

endura® Solids Interceptor

*Uses all the best features of the field-proven Endura Grease interceptor, but **now with solids management capability.***

The Solids Basket Accessory can be fitted directly in to your Endura grease interceptor in place of the inlet baffle or be located within its own stand alone tank for ease of access and location.



14 1/2"

WARRANTED
10
YEARS

The performance of every Grease Interceptor in service, large or small is impacted by the discharge and accumulation of food debris and foreign objects that pass down the drain.

As well as being responsible for the foul odor, food solids left for more than 5-7 days will considerably change the PH of the interceptor contents. This leads to a corrosive mixture that when using a metal interceptor or drainage system will significantly reduce operational life, accelerating corrosion, leaking and failure. Long before this, the internal surfaces of the interceptor, including the baffling system begin to deteriorate, causing the interceptor to progressively lose its operational effectiveness, allowing increasing amounts of Fats, Oil and Grease (FOG) to pass into the downstream drainage system.

The Endura Solids Basket

- Stand alone or integral to interceptor
- Easy to remove and maintain
- Removable dual screen filtration
- **98%+ Solids capture**
- Integrated lifting handles
- Enhanced grease interceptor performance

* Internal development testing

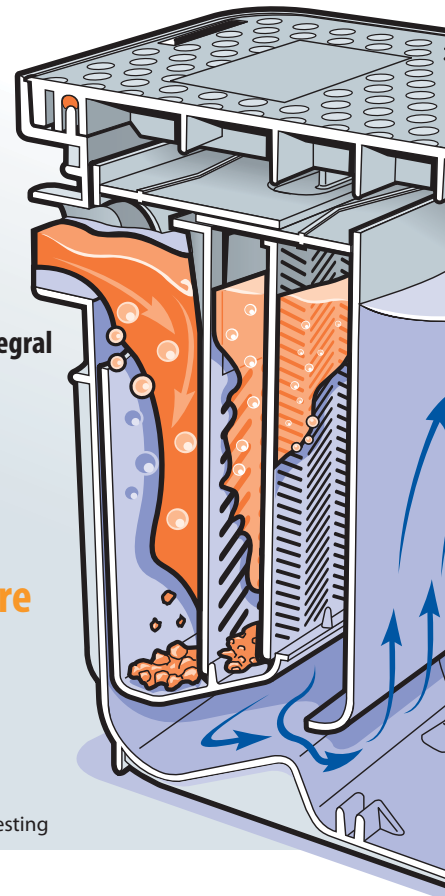

Endura® Solids Interceptor

Sample Specification: Contractor shall install an IPEX Endura® Solids Interceptor as a stand-alone/integrated (delete as applicable) solution. Said interceptor will be installed in accordance with manufacturer's instructions and all parts in direct contact with flow be wholly constructed of engineered thermoplastic capable of withstanding operational temperatures of 220°F (104°C). Baffles will be perforated with slots as opposed circular perforations for enhanced straining of elongated debris e.g. mop strings, spaghetti etc. The solids interceptor will be removable for cleaning and in operation have a minimum flow rate greater than 50GPM when loaded to 50% of its solids-holding capacity. Any baffles/straining method used will also be removable for maintenance and operation impose a dual means of filtration on solid material within the flow. When installed in a stand-alone configuration the tank will meet the same specification as above and have both a lid which is airtight and capable of supporting 440lbs (220kgs). The interceptor shall be supported by a minimum 10 year manufacturer's warranty.

INSTALLATION

The Endura Solids Basket Accessory (SBA) is sold as a separate item to allow the upgrading of any regular height Endura grease interceptor to provide solids management capability. When installing in this application simply remove the inlet baffle from your interceptor, replacing it with the solids basket accessory. This unit should be checked and cleaned **at least** weekly.

Note: Sufficient clearance above the interceptor must be available and maintained for removal and replacement of the solids basket.

Minimum clearance above the interceptor / tank.

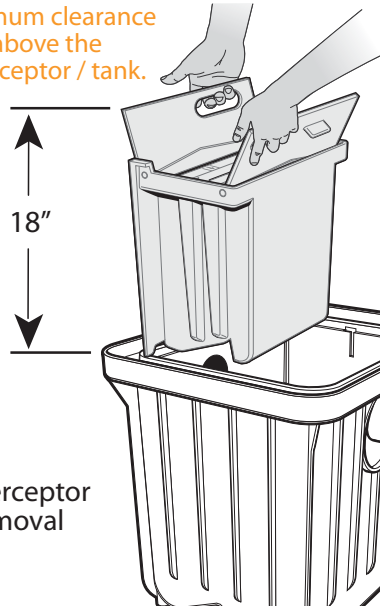

COMPONENTS

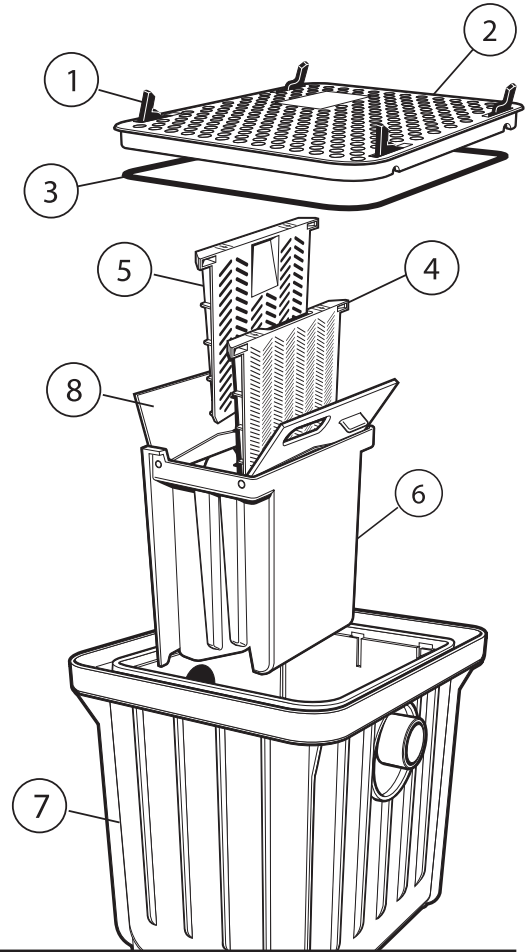

DIMENSIONS

	Solids Interceptor	Solids Basket
A	14.5" (368mm)	7.25" (184mm)
B	17.375" (441mm)	13.875" (352mm)
C	3.5" (89mm)	3" (76mm)
D	12.8" (325mm)	11.375" (289mm)
E	16.3" (414mm)	14.375" (365mm)

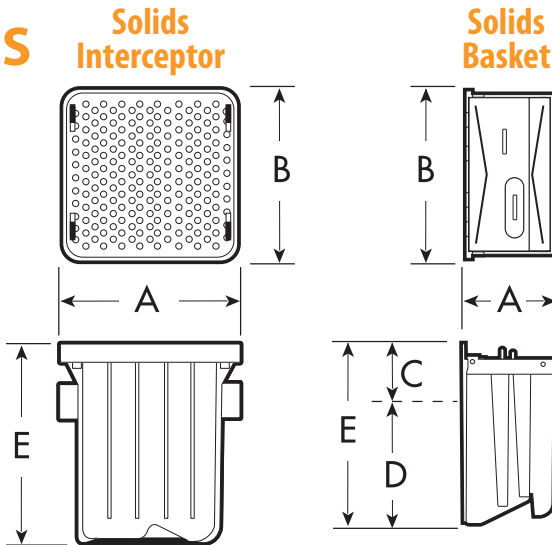

Part No:	Description	Size
3911A02	Solids Interceptor (Complete with SBA)	2"
3911A-1	Solids Basket Accessory (SBA)	N/A

ITEM	Description	Part No:
1	- Latches	#3920A-9
2	- Reinforced Polypropylene Cover	#3910A-2
3	- Cover Gasket	#3910A-5
4	- Fine Screen	#3911-3
5	- Coarse Screen	#3911-2
6	- Solids Container	#3911-1
7	- One-piece tank	#3910A02-1
8	- Handle / Cover	#3911-4



Eastern U.S. Customers
Tel: (289) 881-0120
Toll Free: 1-800-463-9572
Fax: (905) 844-0826

Western U.S. Customers
Tel: (303) 373-1918
Toll Free: 1-888-461-5307
Fax: (303) 373-1923

www.ipexamerica.com | sales@ipexamerica.com