



Your Solutions Partner

Specifications

F.O.B. Sedalia, Missouri 65301



59-E4

(shown with optional casters)

OPTIONS:

- Stainless steel interior
- 4" or 6" stainless legs
- 8", stainless angular legs
- Casters
- Extra Oven racks
- 8' or 11' cord and plug with receptacle
- High voltage (380/415/440/480)
- Pulse Fan option ("XX" controls only)
- Baking station stand on casters (**59-BS**)
- Proofer base (**PFB-1**)
- Extended warranty
- Optional shelf for leg stand
- Double stack-shipped assembled

DUKE MANUFACTURING CO.

2305 N. Broadway

St. Louis, MO 63102

800.735.3853 Toll Free

314.231.5074 Fax

www.dukemfg.com

SS-1061 Half Size Double Oven 59-E4

Approval Stamp(s):

PRODUCT INFORMATION:

PROJECT: _____

ITEM: _____

QUANTITY: _____

MODEL:

Duke Convection Ovens

Half Size - Electric - Double Section

- **59-E4** 8.0 KW input per section

STANDARD FEATURES

- 5 racks/9 rack positions per oven
- Porcelain interior finish
- Single hinged door/door glass
- 16" stainless steel legs
- 2 speed fan

OVEN SECTION

- Stainless steel front, sides and top
- 1" insulation on bottom, sides and back
- 3" insulation on top
- Interior lights

OVEN CONTROLS

- "V" - Basic snap action thermostat (200° - 500°F), 60 minute electric dial timer with continuous sounding buzzer, 2-speed fan
- "XX" - Solid state digital time and temperature controls, 12-hour countdown timer, **Cook and Hold** feature, 2-speed fan, Pulse fan capability

Certifications



Specification subject to change



DUKE CONVECTION OVENS

DBC-2E HALF SIZE - ELECTRIC - DOUBLE SECTION

A.I.A. File No. 35-C-13

Catalog No. DCO-1/2ELECDD

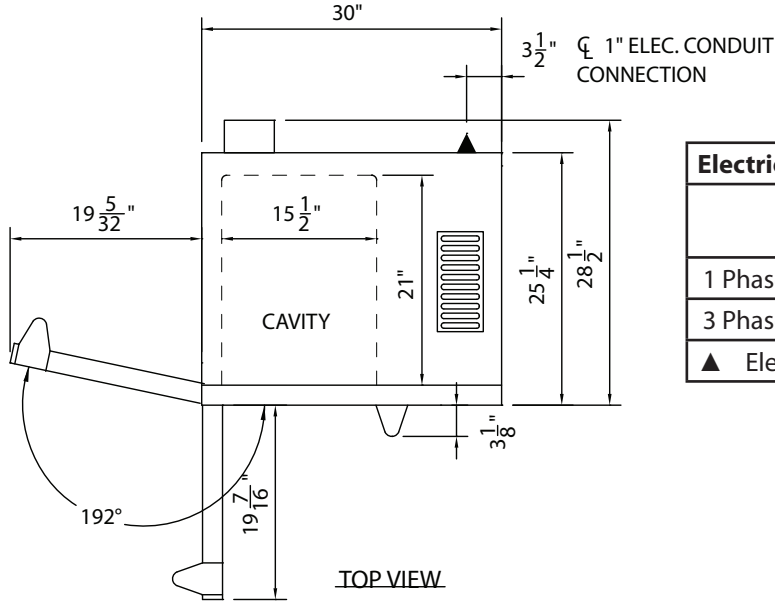

Electrical Specifications - Per Section			
	208V Amps	240V Amps	KW
1 Phase	40.0	35.0	8.0
3 Phase	24.0	21.0	8.0
▲ Electronic connection point			

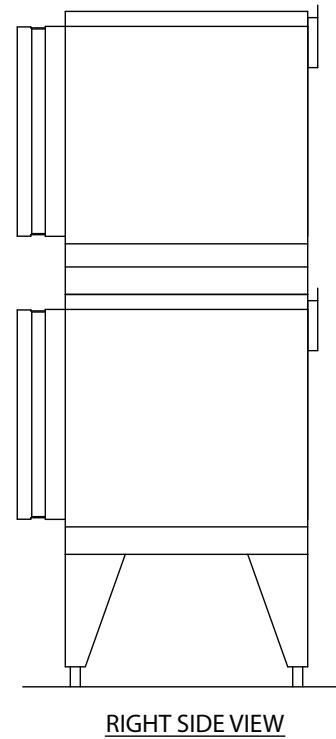
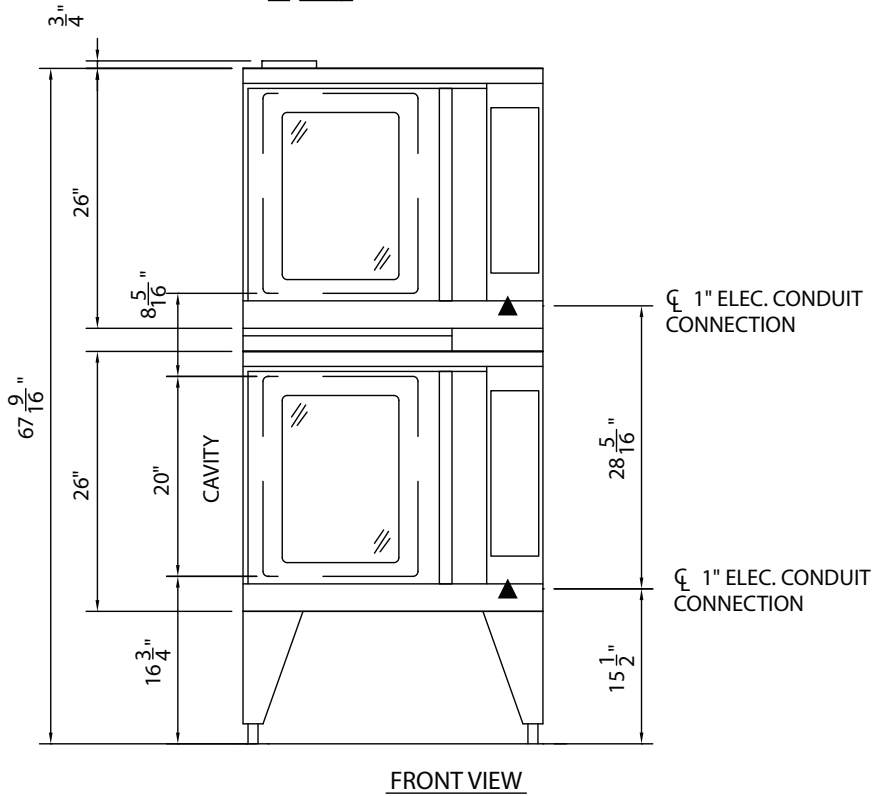

DUKE CONVECTION OVENS - HALF-SIZE - DOUBLE - ELECTRIC

DIMENSIONS:

Freight Class: 85

Model	Depth		Width		Height		Cube ft. crated	Weight	
	in'	cm	in.	cm	in.	cm		lbs.	kg
59-E4	25 1/4	64.1	30	76.2	68 1/4	165.7	36.3	530	241.0



Duke Manufacturing Co.
2305 N. Broadway
St. Louis, MO 63102

Phone: 314-231-1130
Toll Free: 1-800-735-3853
Fax: 314-231-5074

www.dukemfg.com