

Project _____

Item Number _____

Quantity _____

6612S



6612S Value Slicer

Model:

➤ 6612S: 1/2hp Semi-Automatic Slicer



CERTIFIED BY NSF INTERNATIONAL TO MEET
AND EXCEED THE NSF/ANSI 2012 STANDARDS

12" Precision slicing German hollow ground blade
Unique smooth curve transitions to redirect
liquids away from controls and operator
Easily detachable carriage for easy cleaning

Value Series Slicer

Features:

- Light to medium duty, intermediate volume slicer
- Maximum duty 3 hours a day
- Capable of slicing limited amounts of cheese
- Unique drip tray fence redirects liquids away from controls and operator towards distinctive concave base casting for easy cleaning
- Ergonomic comfort design operation
- Powerful 1/2 hp motor standard
- Adjustable slice thickness from 0 to 1/2"
- Easily removable sharpener for cleaning
- Quick and simple disassembly of carriage and feed grip for easy and thorough cleaning
- Sanitary polished and anodized aluminum construction
- Permanently mounted protective edge guard for operator safety
- Heavy duty 3-1/2 lb gravity fed grip

Optional Accessories:

- Stainless steel blade
- Heavy duty clear plastic cover
- Stainless steel vegetable chute
- Sturdy stainless steel stand

Warranty:

- One year, on-site parts and labor

Univex Corporation



WE RAISE THE BAR. WE SET THE STANDARD.

Value Series Slicer

6612S

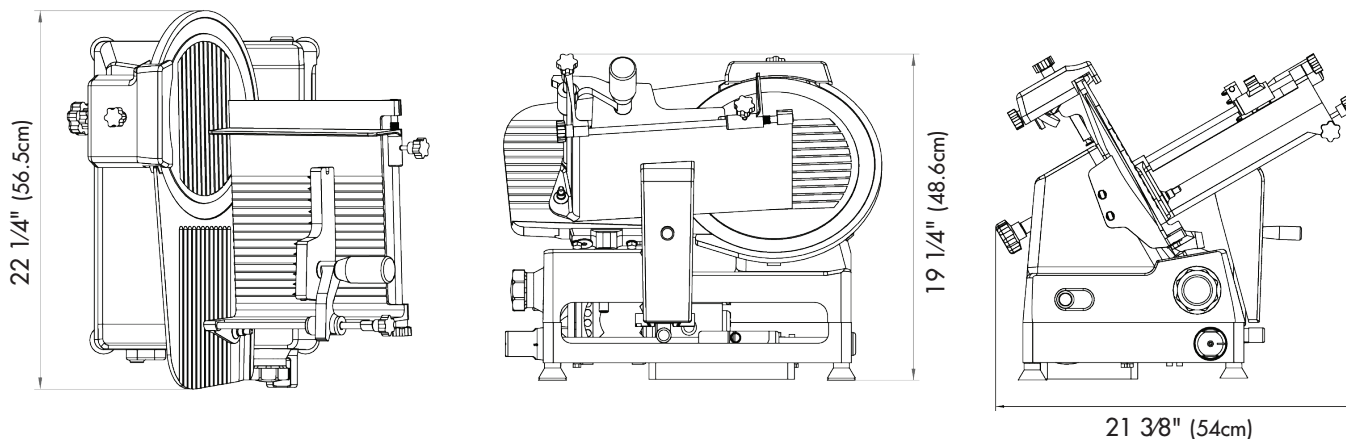

Controls: Manual slice thickness knob, push button on/off, attached blade sharpener, smooth cam auto/ manual knob

Blade Drive Assembly: Belt driven

Carriage Drive Assembly: Gear driven

Blade diameter: 12" (38.48cm) razor sharp blade

Blade RPM: 345 RPM

Maximum slice thickness: .5" (1.27cm)

Maximum product size: Rectangular: 9.25" x 7.5" (24.5cm x 19cm)
 Square: 7.5" x 7.5" (19cm x 19cm)
 Round: 8" (20.3cm)

Construction: Anodized, cast aluminum body for durability and stunning looks

Nema #: 5-15-P

Electrical Information (60Hz)					
	Voltage	Phase	Amps	RPM	hp(kW)
Standard Voltage	115	1	4.0	1680	1/2 (.37)
Optional Voltage	208-240	1	2.5	1680	1/2 (.37)

Carriage Strokes	
	Strokes per minute
11" (27.94cm)	40

Shipping Information		
Net Weight	Shipping Weight	Overall Shipping Dimensions
97.9lbs. (44.4Kg)	116lbs. (52.6Kg)	22" (55.9cm) H x 30" (76.2cm) W x 26" (66cm) D



Univex Corporation
www.Univexcorp.com

3 Old Rockingham Rd
 Salem, NH 03079
 United States of America

TEL: (800)258-6358
 INTL TEL: (603)893-6191
 FAX: (800)356-5614
 INTL FAX: (603)893-1249