



Item # _____

36" Single and Double Deck Ovens

STANDARD FEATURES:

- ◆ Frame constructed of heavy gauge metal solidly welded.
- ◆ All stainless steel front, sides and kick plate.
- ◆ Oven contact surfaces have porcelain finish for easy maintenance.
- ◆ Oven door constructed for heavy use, easily removable for cleaning.
- ◆ Oven safety valve provides 100% shut down if pilot flame goes out.
- ◆ Piezo type, push button (matchless) ignition to light the standing pilot on the oven.
- ◆ "U" shape Oven Burner provides 35,000 BTU/hr for consistent heating. Oven design enhances airflow.



RR-LB

CONVECTION OVEN FEATURES:

- ◆ 30,000 BTU/Hr. "U" burner with automatic ignition.
- ◆ 3 Heavy duty chrome plated racks with 5 position adjustment.
- ◆ Cook and Cool switch.
- ◆ 2 speed (HI/LO) Fan Switch.
- ◆ Thermostat adjustable from 150°F to 500°F.

OPTIONS:

- ◆ Extra oven rack (One per oven is standard).
- ◆ 6" High Casters (2 locking, 2 swivel).
- ◆ Convection Oven.
- ◆ Seismic Flanged Feet.

Royal Ovens have been designed to give the most useful features at an affordable cost. All stainless steel sides, and front are easily cleaned and rugged enough to withstand the constant heavy usage of a busy kitchen. Oven interiors are porcelain coated on all contact surfaces for fast and easy cleanup. The ovens are thermostatically controlled with 100% safety on the pilots to shut off the oven gas flow if the flame should go out. There is a push button ignitor for easy lighting of the oven pilot.

ROYAL RANGE OF CALIFORNIA, INC.
3245 CORRIDOR DRIVE, EASTVALE, CA 91752
(800) 769-2414 in the U.S. (951) 360-1600 Fax: (951) 360-7500
www.royalranges.com E-mail: royalrange@dslxtreme.com
PRINTED IN THE U.S.A. (08/11)



36" Oven Series Specifications

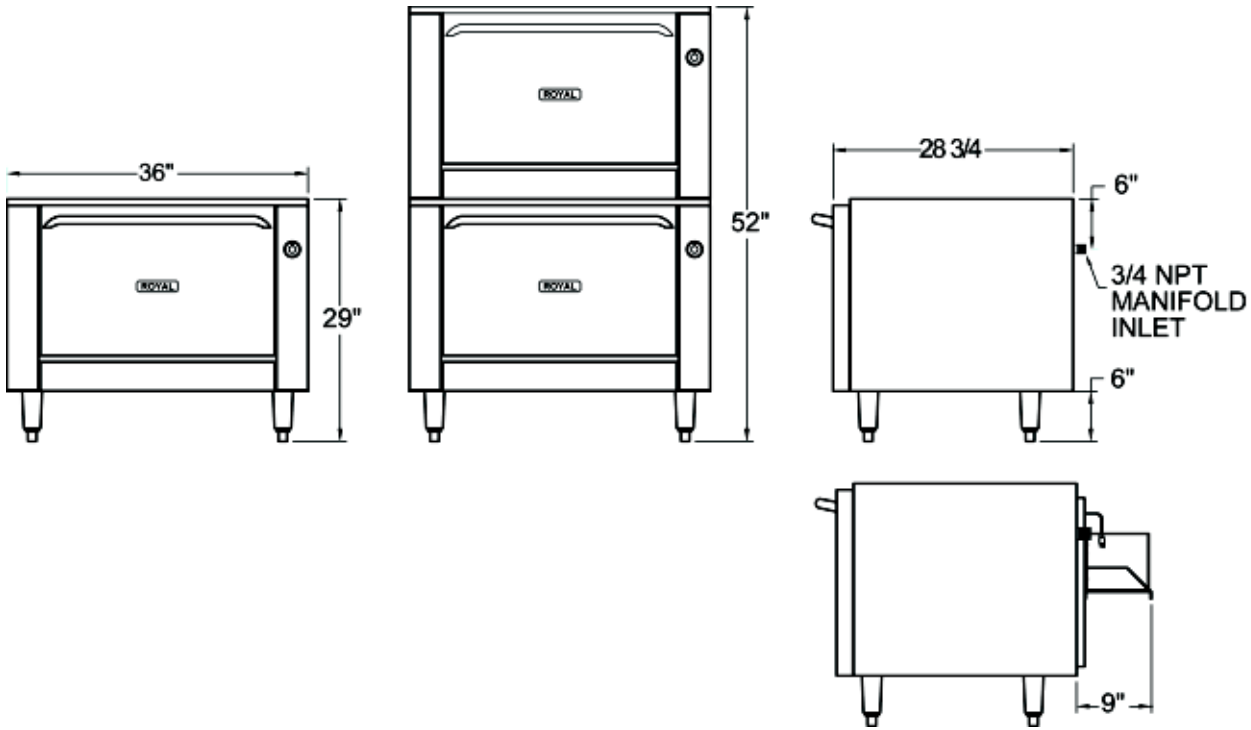

MODEL NUMBER	HEIGHT	OVEN BURNERS	TOTAL BTU	SHIP WEIGHT
RR-36-LB	26"	1 ¹	35,000	185 Lbs.
RR-36-LB-C*	29"	1 ²	30,000	205 Lbs.
RR-36-DS	52"	2 ¹	70,000	373 Lbs.
RR-36-DS-C**	52"	2 ^{1&2}	65,000	390 Lbs.
RR-36-DS-CC***	52"	2 ²	60,000	405 Lbs.

Notes:

1. Standard oven burner @ 35,000 BTU/Hr. each.
2. Convection oven burner @ 30,000 BTU/Hr. each.

* "LB-C" is a single convection oven.

** "DS-C" is a standard oven stacked with a convection oven, specify which is on top.

*** "DS-CC" is a double convection oven stacked.

Electrical requirements Convection Oven: 120VAC 50-60hz, Single phase.

8 amps per oven.

Two speed motor (1725 / 1140 RPM) 1/2 HP.

Provided with 6' power cord fitted with a standard three prong grounded plug.

Gas Connection: 3/4" NPT on the right hand rear of the appliance

The pressure regulator (supplied) is to be connected here by the installer.

Gas pressure: 5" W.C. - Natural Gas

10" W.C. - Propane

Combustible Clearances:

15 inches sides

4 inches rear

Non-combustible Clearances:

0 inches sides

0 inches rear

Specify type of gas and altitude, if over 2,000 feet, when ordering.

Due to continuing product development to ensure best possible performance, these specifications are subject to change without prior notification

ROYAL RANGE OF CALIFORNIA, INC. 3245 CORRIDOR DR. EASTVALE, CA 91752 www.royalranges.com

(800) 769-2414, in the U.S. (951) 360-1600, Fax: (951) 360-7500, E-mail: royalrange@dslextreme.com PRINTED IN THE U.S.A. (08/11)