

REFRIGERATOR MANUFACTURER
Turbo air
 more durable, efficient, beautiful

4184 E. Conant St.
 Long Beach, CA 90808
 Tel. 310-900-1000
 Fax. 310-900-1077
www.turboairinc.com

Project :
 Model # :
 Item # : Qty :
 Available W/H :
 Approval :

Curved Glass Bakery Cases

Display Cases
 Bakery Cases - Combination Cases

REFRIGERATED & DRY CASE COMBINATION

Model : TCGB-60-CO



**Self-Cleaning
 Condenser**



NO MAINTENANCE REQUIRED

* Red wine and white color come standard

≡ FEATURES & BENEFITS ≡

- **Self-cleaning condenser device** *Only at Turbo Air*
 The accumulation of dust in the condenser causes the failure or breakdown of refrigerators. Refrigerators run normally until they reach a certain level of accumulation. At some point, when they are over the limit, their performance drops quickly resulting in damage to, or disposal of the stored products in refrigerators. The self-cleaning condenser device keeps the condenser clean and prevents system failure by automatically brushing daily.
- **Attractive, elegant, glass sided Euro design**
 Curved tempered front glass and minimal frame provide full product visibility to optimize display effects. Its elegant contemporary euro design and luxurious wine colored case will not only enhance any store atmosphere but also will keep product presentation at its best and beautiful.
- **Cantilevered wired shelves adjustable up and down, tilted**
- **304 stainless steel floor and airflow grille**
- **High-density polyurethane insulation**
 The entire cabinet structure is foamed-in-place using high density, CFC free polyurethane insulation.
- **Sliding rear doors for product loading & unloading**
- **Heavy duty, white PE coated wire shelves**
- **Environmentally friendly, efficient refrigeration system**
 Turbo Air's refrigerators are designed with oversized and balanced environmentally friendly R-134A (CFC Free) refrigeration. These include large evaporators and condensers for faster cooling and balanced temperature throughout the cabinet.
- **Safety shielded LED lighting interior**
- **Rear access of compressor compartment for quick and easy service**
- **Refrigerated bakery case holds avg. 33°F ~ 41°F for fresher bakery products**



Model	CU./FT.	# of Shelves	HP	AMPS	Crated Weight (lbs.)	L x D x H (inches)
TCGB-60-CO	9.2 x 2	4	1/3	6.5	721	60 1/2 x 34 1/4 x 50 1/8

Model : TCGB-60-C0

ELECTRICAL DATA	
Voltage	115/60/1
Plug Type	Ⓜ NEMA 5-15P
Full Load Amperes	6.5
Compressor HP	1/3
Refrigerant	R-134A
DIMENSIONAL DATA	
Net Capacity (cu. ft.)	9.2 x 2
Ext. Length Overall (in.)	60 1/2 (1537mm)
Ext. Depth Overall (in.)	34 1/4 (870mm)
Ext. Height Overall (in.)	50 1/8 (1273mm)
Int. Length Overall (in.)	28 (711mm) x 2
Int. Depth Overall (in.)	27 3/4 (705mm)
Int. Height Overall (in.)	22 3/4 (578mm)
Net Weight (lbs.)	629
Gross Weight (lbs.)	721
# of Shelves	4

Design and specifications subject to change without notice.
Actual shipping weight may differ due to extra packing materials for product protection.

- **WARRANTY : 2 Year Parts and Labor Warranty**
Additional 3 Year Warranty on Compressor

- **Self-contained system, no plumbing required**
- **Simple plug-in installation**
- **Four point leveling system**
- **Easy access control panel**
- **Recommended operating conditions:**

TCGB models are designed to operate in environments where temperature & humidity do not exceed 75°F and 55% relative humidity.

PLAN VIEW

(unit : inch)

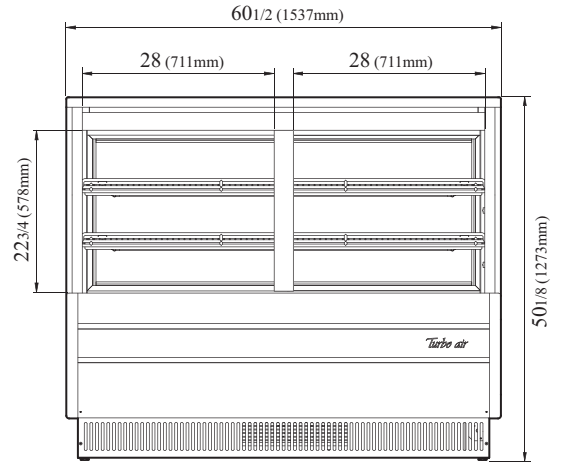

FRONT VIEW

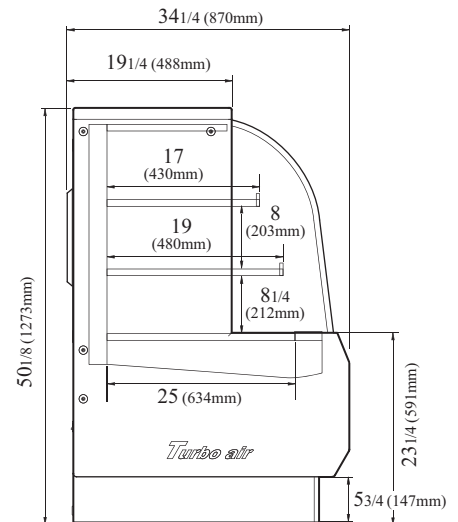

SIDE VIEW

Ver.201601



- Turbo Air : 800-627-0032
- GK : 800-500-3519
- Warranty : 800-381-7770
- AC : 888-900-1002