

**REFRIGERATOR MANUFACTURER**  
**Turbo air**  
 more durable, efficient, beautiful

4184 E. Conant St.  
 Long Beach, CA 90808  
 Tel. 310-900-1000  
 Fax. 310-900-1077  
[www.turboairinc.com](http://www.turboairinc.com)

Project :	
Model # :	
Item # :	Qty :
Available W/H :	
Approval :	

## Glass Door Freezer

Glass Door Merchandisers  
 Freezers

### FEATURES / BENEFITS

**Model : TGF-49F(B)**

#### ■ DIGITAL TEMPERATURE CONTROL SYSTEM

Provides precise and constant temperature. This level of precision allows food products to remain fresh over an extended period of time.

#### ■ HIGH-TECH MONITOR

The unit will beep if the door has been opened for more than 30 seconds. The monitor digitally displays the present temperature and current status of the freezer. You can easily change the temperature by adjusting the thermostat.

#### ■ LED LIGHTING INTERIOR DISPLAY SYSTEM

Brighter and longer lasting LED lights provide attractive, enhanced illumination compared to fluorescents. It saves energy by producing less heat, while maximizing the visibility in the display area.

#### ■ LED ADVERTISING PANEL

LED lighting offers 10 times longer lasting life than fluorescents and conserves energy as well.

#### ■ AUTOMATIC CONDENSER CLEANING SYSTEM

The accumulation of dust in the condenser causes the failure or breakdown of refrigerators. Especially for freezers, they run normally until they reach a certain level of accumulation. At some point, when they are over the limit, their performance drops quickly resulting in damage to, or disposal of the stored products in freezers. The automatic condenser cleaning system keeps the condenser clean and prevents system failure by automatically brushing daily.

#### ■ EFFICIENT REFRIGERATION SYSTEM

Turbo Air's freezers are designed with oversized and balanced (CFC Free R-404A) refrigeration systems. These include efficient evaporators and condensers for faster freezing and greater efficiency.

#### ■ AUTOMATIC EVAPORATOR FAN MOTOR DELAYS

Through stopping the evaporator fan when the freezer door opens, the circulation of hot, moist air into the freezer is prevented. This increases energy efficiency and lengthens the life of the compressor.

#### ■ TRIPLE PANE HEATED GLASS DOORS WITH HEAT REFLECTING FILM

Equipped with unique triple pane heated glass doors with a layer of patented, transparent thermal insulating film applied between the glass layers. Lightweight door construction reduces door maintenance and bushing wear, and facilitates smooth door opening.

#### ■ ADJUSTABLE, HEAVY DUTY, PE (POLYETHYLENE) COATED WIRE SHELVES

#### ■ HIGH-DENSITY POLYURETHANE INSULATION

The entire cabinet structure is foamed-in-place using high density, CFC free polyurethane insulation.

#### ■ TASTEFUL AND MODERN APPEARANCE

The design of our products is one of our top priorities. Whether you have a restaurant, bar, convenience store or gas station, Turbo Air refrigerators will compliment the appearance of your operation.

#### ■ ERGONOMICALLY DESIGNED DOORS

Customers' fatigue fades away with easy grip handles and doors that open effortlessly. These features along with self-closing doors make this the ultimate choice in customer convenience.



**FREEZER HOLDS -15°F ~ 5°F FOR THE BEST IN FROZEN FOOD PRESERVATION**



Model	Swing Door	CU./FT.	#of Shelves	HP	AMPS	Crated Weight (lbs.)	L x D x H (inches)
<b>TGF-49F(B)</b>	<b>2</b>	<b>49</b>	<b>8</b>	<b>1 1/2</b>	<b>11</b>	<b>587</b>	<b>54 3/8 x 29 3/4 x 77</b>

## Model : TGF-49F(B)

ELECTRICAL DATA	
Voltage†	115/208~230/60/1
Plug Type†	 NEMA L14-20
Full Load Amperes	11
Compressor HP	1 1/2
Cord Length ft.	7
Refrigerant	R-404A
DIMENSIONAL DATA	
# of Doors	2
Net Capacity cu. ft.	49
Ext. Length Overall in.	54 3/8 (1382mm)
Ext. Depth Overall in.*	29 3/4 (756mm)
Ext. Height Overall in.	77 (1956mm)
Int. Length Overall in.	50 1/2 (1283mm)
Int. Depth Overall in.	24 1/8 (614mm)
Int. Height Overall in.	60 3/8 (1535mm)
Gross Weight lbs.	587
Net Weight lbs.	554
# of Shelves	8
Shelf Size (LxD) in.	21 3/4 x 22 1/2

Design and specifications subject to change without notice.  
Actual shipping weight may differ due to extra packing materials for product protection.  
\* Depth does not include 1-3/8" for glass door handles.  
† TGF-49F requires dual voltage 115/208~230V (NEMA L14-20)

■ **WARRANTY : 2 Year Parts and Labor Warranty  
Additional 3 Year Warranty on Compressor**

- WHITE AND BLACK COLOR CABINET AVAILABLE
- TRIPLE PANE HEATED GLASS DOOR
- 4" SWIVEL CASTERS AVAILABLE (OPTIONAL)

■ **OPTIONAL ACCESSORIES :**

- Additional PE coated wire shelves

### PLAN VIEW

(unit : inch)

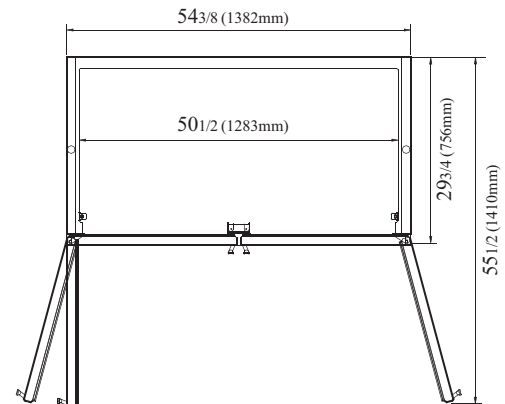

PLAN VIEW

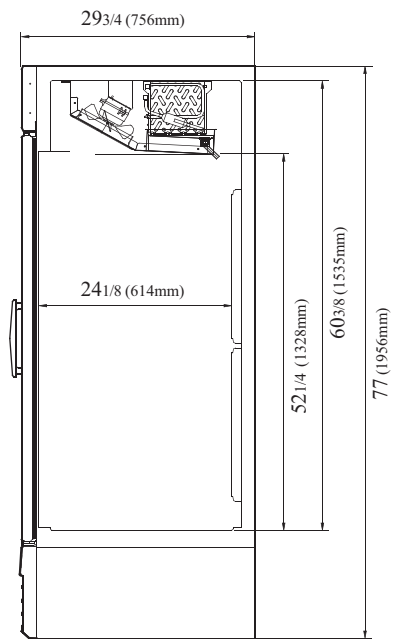

SIDE VIEW

Ver.201401



- Turbo Air : 800-627-0032
- GK : 800-500-3519
- Warranty : 800-381-7770
- AC : 888-900-1002