

**REFRIGERATOR MANUFACTURER**  
**Turbo air**  
 more durable, efficient, beautiful

4184 E. Conant St.  
 Long Beach, CA 90808  
 Tel. 310-900-1000  
 Fax. 310-900-1077  
[www.turboairinc.com](http://www.turboairinc.com)

Project :	
Model # :	
Item # :	Qty :
Available W/H :	
Approval :	

## Ice Cream Freezer

Ice Cream Merchandisers  
 Horizontal / Chest Freezers

**Model : TSD-47CF**



### ≡ FEATURES & BENEFITS ≡

■ **Environmentally friendly, efficient refrigeration system**

Turbo Air's freezers are designed with oversized and balanced environmentally friendly R-134A (CFC Free) refrigeration system. These include large evaporators and condensers for faster freezing and greater efficiency throughout the cabinet.

■ **Tempered, energy-saving, low emissivity glass sliding top**

Reduced outer heat gain and lowers energy consumption. It enhances energy efficiency and minimizes condensation.

■ **Attractive curved glass lids**

Optimize eye-catching display and impulse sales. Economical size and design for convenient access and fast service in high traffic area.

■ **Easy temperature control mode is energy efficient**

There is no need to reach inside the freezer to control the temperature. External temperature control knob allows easy adjustment and keeps cold air inside saving energy.

■ **High-density polyurethane insulation**

The entire cabinet structure is foamed-in-place using high density, CFC free polyurethane insulation.

■ **Manual defrost system**

■ **Wire baskets come standard**

■ **White, anti-rust coating on the exterior reduces fingerprints**

■ **Freezer holds -9°F ~ 11°F for the best in frozen food preservation**



Model	Sliding Door	CU./FT.	Baskets	HP	AMPS	Crated Weight (lbs.)	L x D x H* (inches)
<b>TSD-47CF</b>	<b>2</b>	<b>10.5</b>	<b>3</b>	<b>1/3</b>	<b>3.5</b>	<b>155</b>	<b>47 7/8 x 23 3/8 x 32 5/8</b>

## Model : TSD-47CF

ELECTRICAL DATA	
Voltage	115/60/1
Plug Type	Ⓜ NEMA 5-15P
Full Load Amperes	2.5
Compressor HP	1/4
Cord Length ft.	7
Refrigerant	R-134A
DIMENSIONAL DATA	
# of Doors	2
Net Capacity cu. ft.	7.3
Ext. Length Overall in.	35 1/4 (895mm)
Ext. Depth Overall in.	23 3/8 (595mm)
Ext. Height Overall in.*	31 1/2 (800mm)
Int. Length Overall in.	30 1/8 (766mm)
Int. Depth Overall in.	18 3/8 (466mm)
Int. Height Overall in.	27 1/2 (698mm)
Net Weight lbs.	121
Gross Weight lbs.	125
# of Baskets	2
Net Capacity Gal.	55

Design and specifications subject to change without notice.  
Actual shipping weight may differ due to extra packing materials for product protection.  
\* Height does not include 3-1/2" for caster height.

- **WARRANTY : 1 Year Parts and Labor Warranty**  
**Additional 4 Year Warranty on Compressor**
- **No plumbing requires**
- **Self-contained system**
- **1.5" dia. casters standard**

## PLAN VIEW

(unit : inch)

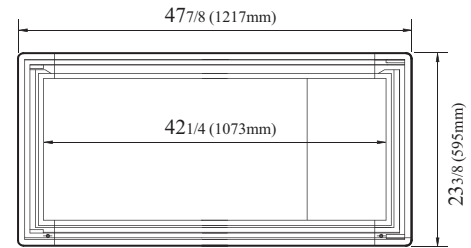

PLAN VIEW

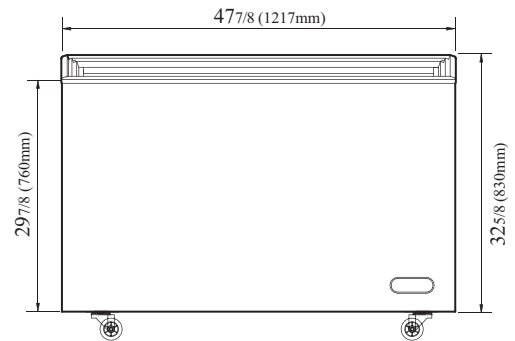

FRONT VIEW

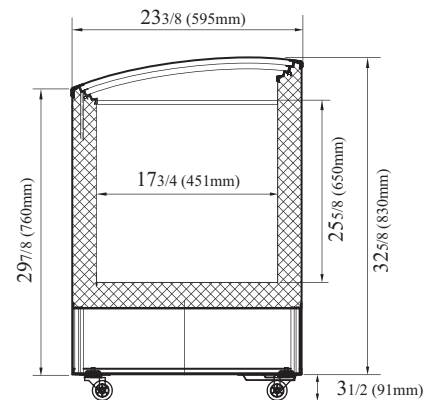

SIDE VIEW

Ver.201501



- Turbo Air : 800-627-0032
- GK : 800-500-3519
- Warranty : 800-381-7770
- AC : 888-900-1002