



Accu-STEAM™ GRIDDLE EG SERIES

Electric/Steam-Heated, Stand-Mounted Griddle

Cooking Surface: 24" 36" 48" Wide; 29" 24" Deep

Short Specification

Griddle shall be an AccuTemp Model EG

Specify:

Volt	29" D* 24" W	29" D* 36" W	29" D* 48" W	24" D* 24" W	24" D* 36" W	24" D* 48" W
208	<input type="checkbox"/>	<input type="checkbox"/>	<input type="checkbox"/>	<input type="checkbox"/>	<input type="checkbox"/>	<input type="checkbox"/>
240	<input type="checkbox"/>	<input type="checkbox"/>	<input type="checkbox"/>	<input type="checkbox"/>	<input type="checkbox"/>	<input type="checkbox"/>
480	<input type="checkbox"/>	<input type="checkbox"/>	<input type="checkbox"/>	<input type="checkbox"/>	<input type="checkbox"/>	<input type="checkbox"/>

*specify "A" for 29", and "B" for 24" depth.

electric-heated unit, with a hermetically-sealed vacuum chamber that produces steam and heats the 8-gauge stainless steel griddle plate. Efficient steam heat transfer provides 200–400°F (93–204°C) operating temperature range and uniform griddle surface temperatures of $\pm 3^\circ\text{F}$ ($\pm 1^\circ\text{C}$). Griddle fabricated from cold-rolled stainless steel with 4.5" high back splash, sides that taper from 4.5" to 1.7", a 4" wide by 1" deep full front grease trough and 1½–2 gallon grease drawer. Unit to be NSF and U.L. listed and manufactured in the U.S.A.

Construction Features

- Cold-rolled and annealed stainless steel griddle plate with polished stainless steel body and stand
- 8 gauge griddle plate with 4.5" high rear splash and 4.5 to 1.7" tapered side walls
- 4" wide by 1" deep full front grease trough
- 2" x 4" drop chute to 1½–2 gallon capacity grease drawer inside enclosed compartment
- Heavy tubular open leg stainless steel stand with bottom shelf (optional)
- 5" heavy-duty casters standard, front are locking type (optional)

Performance Features

- Hermetically-sealed vacuum chamber mounted to and below griddle plate
- 9.6-kW [24"] or 14.25-kW total power, long-life low watt density heating elements mounted inside vacuum chamber and immersed in chemically pure water (Water never needs replacement)

- Steam transfers heat evenly to entire pan surface with only $\pm 3^\circ\text{F}$ ($\pm 1^\circ\text{C}$) in temperature variation
- Rapid surface temperature recovery [10 seconds or less] allows turning product to same spot
- Smooth cold-rolled stainless steel griddle surface speeds and simplifies cleaning

Standard Control Features

- Power-On switch & indicator light
- Heating indicator light
- 200–400°F (93–204°C) solid state thermostat
- Easy front service access to controls

Cooking Capacity & Applications

Effective Cooking Area

Depth	24" Wide	36" Wide	48" Wide
29"	677 sq. in.	1017 sq. in.	1358 sq. in.
24"	558 sq. in.	838 sq. in.	1119 sq. in.

Typical Burger Production (29" Deep Model)

Type	24" Wide	36" Wide	48" Wide
Frozen	40 lbs./hour	60 lbs./hour	80 lbs./hour
Fresh	60 lbs./hour	90 lbs./hour	120 lbs./hour

Griddle Applications include

- Pancakes, Eggs, Sausage, French Toast
- Burgers, Grilled Onions, Toasted Buns
- Grilled Cheese, Monte Cristo & Ruben Sandwiches
- Fried Potatoes, Fish, Chicken Breasts, Sandwich Steaks, Liver and MORE

Approvals

- Griddle to be NSF Listed
- Griddle to be U.L. Listed



Installation Requirements

- 208/3 240/3 480/3 240/1 Power Source (See other side for AMP requirements.)
- 6' power cord with plug comes standard

Options & Accessories

- Tabletop model with 4" legs and adjustable bullet feet
- "U" Channel for connecting two griddles
- Front mounted condiment board/prep shelf—8" wide stainless steel
- Heavy tubular open leg stainless steel stand with bottom shelf with 5" casters
- Heavy tubular open leg stainless steel stand with 2 shelves with 5" casters
- Condiment Board



EG-A36 Model Shown with Optional Stand



ACCU-STEAM™ GRIDDLE EG SERIES

Electric/Steam-Heated, Stand-Mounted Griddle

Cooking Surface: 24" 36" 48" Wide; 29" 24" Deep

TOP VIEW

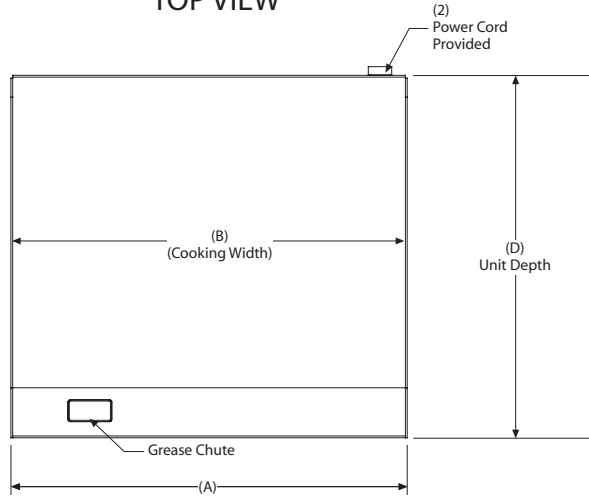

EG-A & EG-B Series Griddle Specifications						
Model	EG-A24	EG-B24	EG-A36	EG-B36	EG-A48	EG-B48
KW Input	9.6 kW		14.25 kW		14.25 kW	
208/3 Amp Load	26.68		39.56		39.56	
240/1 Amp Load	40		not available		not available	
240/3 Amp Load	39.58		34.28		34.28	
480/3 Amp Load	15.41		22.87		22.87	
Unit Width (A)	24 ¹ / ₄ " [616]		36 ¹ / ₄ " [921]		48 ¹ / ₄ " [1226]	
Cooking Width (B)	23 ⁷ / ₈ " [606]		35 ⁷ / ₈ " [911]		47 ⁷ / ₈ " [1216]	
Cooking Surface Depth (C)	28 ³ / ₈ " [721]	23 ³ / ₈ " [594]	28 ³ / ₈ " [721]	23 ³ / ₈ " [594]	28 ³ / ₈ " [721]	23 ³ / ₈ " [594]
Unit Depth (D)	33 ¹ / ₈ " [841]	28 ¹ / ₈ " [714]	33 ¹ / ₈ " [841]	28 ¹ / ₈ " [714]	33 ¹ / ₈ " [841]	28 ¹ / ₈ " [714]
Effective Cooking Area	677sq.in.	558sq.in.	1017sq.in.	838sq.in.	1358 sq.in.	1119 sq.in.
Grease Pan Capacity	1 ¹ / ₂ gal.		2 gal.		2 gal.	
NEMA Plug (208/240)	15-50P		15-50P		15-50P	
NEMA Plug (480)	L16-20P		L16-30P		L16-30P	

FRONT VIEW

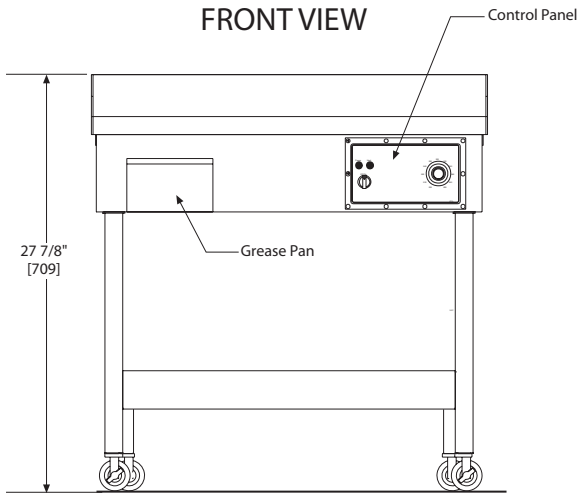

RIGHT SIDE VIEW

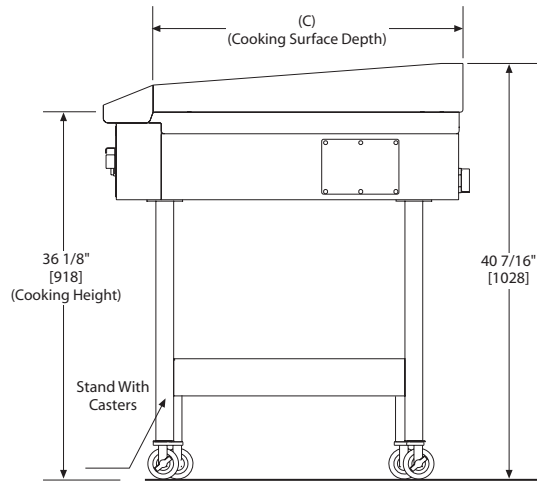

Notes:

1. Dimensions in brackets [] are metric.
2. 5' power cord with plug provided.



EG-A36 Model Shown with Optional Stand