



The clean solution



## DV 80.2

**HOT WATER  
SANITIZING  
DOOR-TYPE  
DISHWASHER**

### Special Features:

- **Auto Safe temperature control system** - Guarantees 180°F (82°C) sanitizing final rinse temperature, regardless of incoming water temperature
- **MIKE 2 electronic control system** - advanced micro-computer technology for service diagnostics and end-user dishmachine settings. Includes one-touch operation, one-touch selection of three different cycle lengths, automatic temperature monitoring with digital display, and advanced service diagnostics
- **Automatic push-handle cycle start**
- **Active Plus filtration system** - Double filtration of wash water removes food soil, improves washing efficiency and saves detergent while easing cleaning chores
- **Soft Start wash pump** - Protects dishes and glasses from chipping or breaking
- **Aqua-Stop** - Automatically stops machine operation and turns off the external fill valve if an internal leak is detected
- **Built-in booster heater with power rinse pump** - Guarantees constant final rinse pressure and temperature for consistent, outstanding results

### Standard Features:

- **ENERGY STAR** Qualified
- Capacity **61** racks per hour
- Water consumption **0.74** gallons (2.8 liters) per rack
- Double-wall construction keeps heat inside the machine, reducing energy consumption and heat loss into the dishroom environment
- Variable programmed time cycles - 59, 90 and 210 seconds
- Fully automatic - automatic fill, automatic start, and automatic reset
- Pumped drain for both floor and wall drain applications
- Machine shutdown activates an automatic rinse of the wash chamber to ease cleaning
- Stainless steel non-clogging wash and rinse arms
- Sloped ceiling is safer for the user and prevents dripping of soiled water onto sanitized ware
- Front mounted controls with digital temperature displays
- 1 Hp (0.75 kW) wash pump
- 304 and 316L stainless steel construction for corrosion resistance
- Type A air gap system eliminates need for vacuum breaker
- Easily accessible detergent and rinse aid ports for fast and easy chemical dispenser installation
- Field-convertible for use in either straight-through or corner applications

### Options:

- **Waste Air Heat Recovery System** - reclaims machine heat as free energy to preheat the incoming rinse water. This conserves energy and permits operation without a ventilation hood.\*
- Built-in liquid detergent and rinse aid pumps
- Flanged, bolt-down feet
- External vent fan control
- Drain water tempering kit

\* **Subject to local code requirements.**



# Dimensions - without Waste Air Heat Recovery System



Electrical terminal block  
Strain relief provided at lower rear of machine. Adequate slack in the wiring should be provided to allow the machine to be moved for servicing.



Fresh water connection  
3/4" female garden hose supply connection is provided. If using supplied external Y-strainer, female garden hose adapter may be removed to provide 1/2" NPT male or 3/4" NPT female connection as required. Supplied hose is 4' 7" (2616mm) in length.



Drain connection  
Requires indirect connection to 1-1/2" (38mm) drain pipe (wall or floor). Supplied hose is 4' 7" (2616mm) long and should be cut to appropriate length at time of installation to allow machine to be repositioned for servicing.

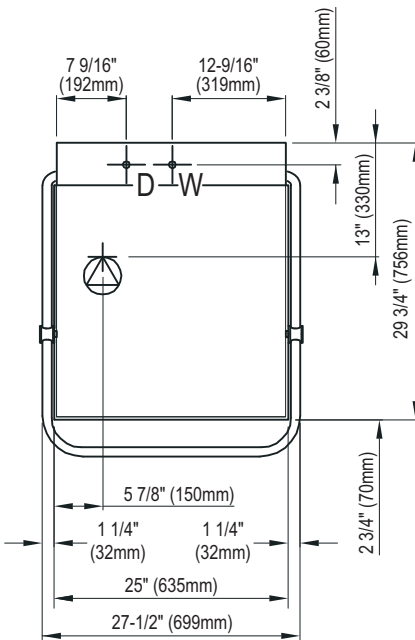
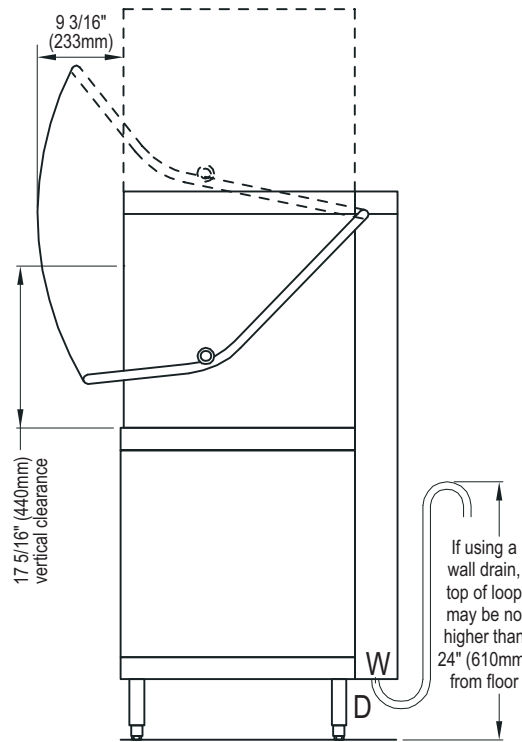
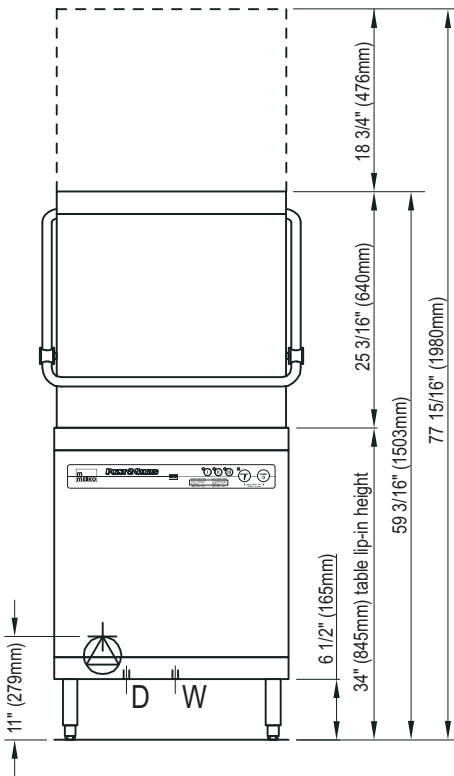

## Recommended Table Construction and Position

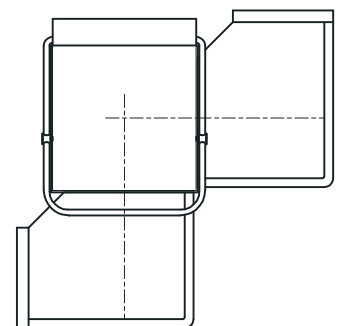
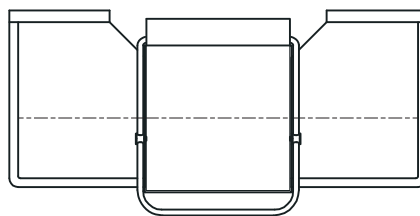
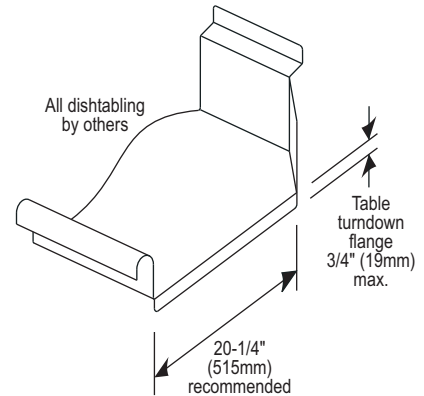
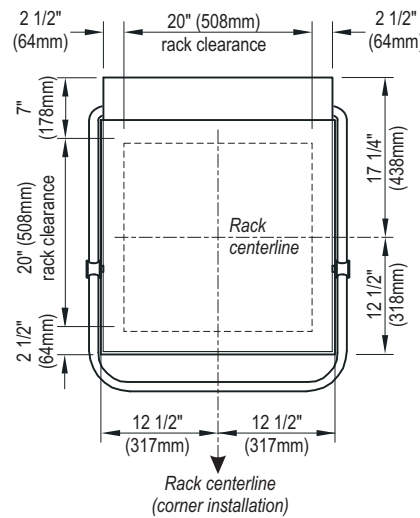

Dishtabling shown for dimensional purposes only. All dishtabling to be provided by others.

All dimensions from floor +/- 1/2" (13mm) due to adjustable feet.

## Dimensions - with Waste Air Heat Recovery System

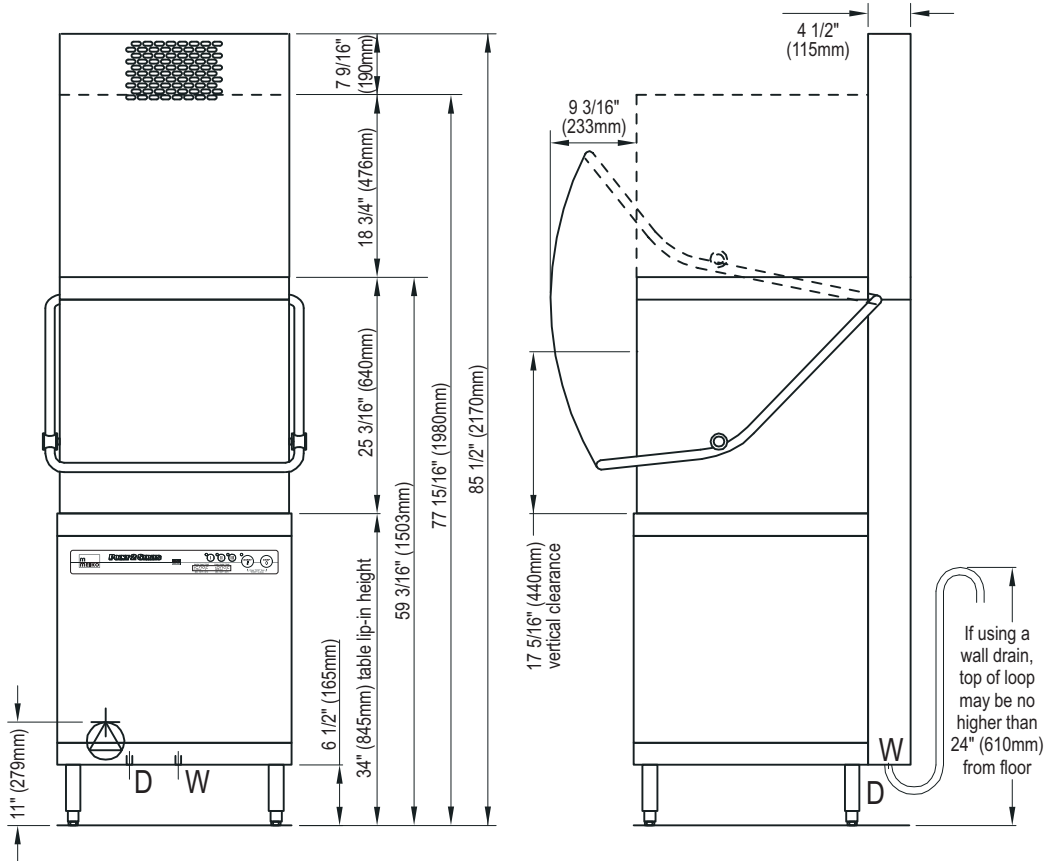

### Tabling Cutout for Corner Installations

If backsplash is higher than 2-1/2" (64mm), cut out as shown to clear door handle.

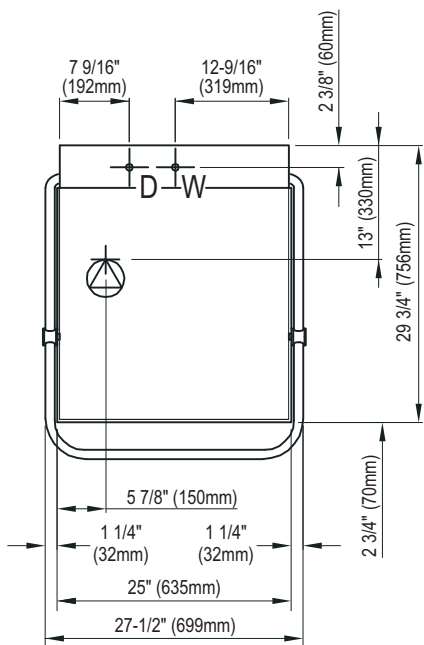
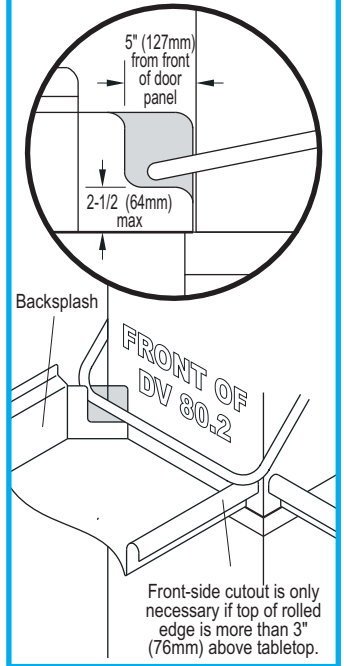

### Corner Installations

The DV 80.2 (with, or without, the optional Waste Air Heat Recovery System) is field-convertible from straight-through to corner application in minutes, without additional parts.

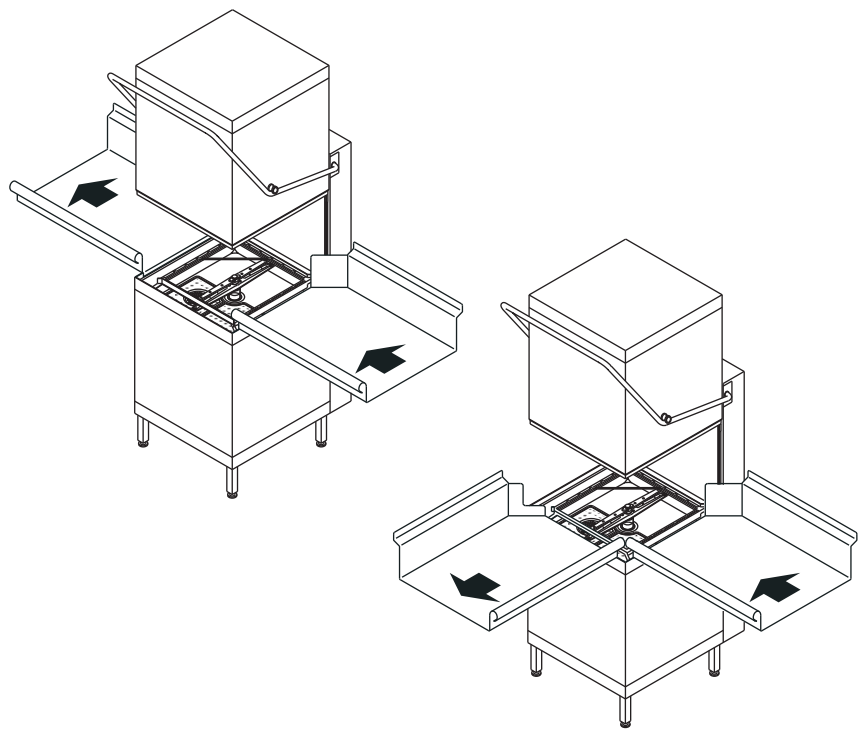

All dimensions from floor +/- 1/2" (13mm) due to adjustable feet.

## Technical Specifications

### Optimum Capacity:

Racks per hour .....	61
Dishes per hour .....	1525
Glasses per hour .....	2196

### Optimum Cycle Time (Seconds):

Wash cycle .....	40
Dwell / drain time .....	11
Rinse cycle .....	8
Heat Recovery cycle (with Waste Air Heat Recovery System) .....	30
Total cycle:	
• Standard .....	59
• With Waste Air Heat Recovery System .....	89

### Water Requirements:

Incoming water temperature:	
• Standard .....	140°F (60°C) recommended
• With Waste Air Heat Recovery System ...	70°F (21°C) maximum
Water Consumption per Rack .....	0.74 gals. (2.80 liters)
Water Consumption per Hour (max) .....	45.14 gals. (170.87 liters)
Flow Pressure .....	8.7-72.5 psi (0.6-5.0 bars)
Incoming Waterline .....	3/4" garden hose
Drain line size .....	7/8" ID, 1-1/8" OD flexible hose
Maximum drain flow rate .....	15 gals. (56.8 liters) per minute

### Required Operating Temperatures:

Wash (Minimum) .....	150°F (66°C)
Rinse (Minimum) .....	180°F (82°C)

### Tank Capacities:

Wash Tank .....	5.81 gals. (22 liters)
Booster Heater .....	2.77 gals. (10.5 liters)

### Electrical Requirements:

Wash Tank Heat .....	6 kW
Booster Heater .....	9 kW
Wash Pump .....	1 HP (0.75 kW)
Approximate Total Load Amps:	
• 208-230/60/1 .....	64.8 A @ 208V, 71.0 A @ 230V
• 208-230/60/3 .....	50.1 A @ 208V, 54.8 A @ 230V
• 460/60/3 .....	26.7 A @ 460V

### Dimensions:

Width .....	25" (635mm)
Depth .....	29-3/4" (756mm)
Height	
• Standard .....	59-3/16" (1503mm)
• With Waste Air Heat Recovery System .....	85-1/2" (2170mm)
Inside Clearance Height .....	17-5/16" (440mm)
Wall Clearance .....	Rear 1" (25mm) min.

### Machine / Shipping Details:

Shipping Weight .....	334 lbs. (151.5 kg)
Shipping Size (W x D x H) .....	40" x 40" x 66" (1016 x 1016 x 1677mm)

This machine may not pass through standard doorways without machine disassembly or doorway modification. Check all dimensions carefully prior to ordering, or contact MEIKO at [sales@meiko.us](mailto:sales@meiko.us) for assistance.

## Specification

DV 80.2 Item Number \_\_\_\_\_

Unit will be an NSF and ETL-listed MEIKO DV 80.2 hot water sanitizing door type dishwasher.

Operating voltage will be:

\_\_\_ 208-230 V / 60 Hz / 1 Ph

\_\_\_ 208-230 V / 60Hz / 3 Ph

\_\_\_ 460 V / 60 Hz / 3 Ph

Unit will have front mounted microcomputer controls and utilize 0.74 gallons (2.8 liters) fresh rinse water per cycle. Unit will have an automatic push-handle cycle start feature. Unit will utilize a fresh water pumped rinse for constant rinse pressure and temperature every cycle. Unit will have integral wash tank soil removal system to maintain clean wash water. Unit will have built-in temperature safeguards to guarantee final rinse temperature meets minimum 180°F (82°C) requirement. Wash pump will be equipped with a soft start feature to reduce risk of chipped or broken ware. Unit will incorporate features to stop operation and turn off external fill valve if an internal leak is detected.

Unit will have variable time cycles for heavier than normal soil loads. Standard cycle length will be 59 seconds. Minimum cycle length for units equipped with optional Waste Air Heat Recovery System will be 89 seconds.

### "Auto Safe" Feature

The DV 80.2 guarantees that the minimum NSF 180°F (82°C) sanitizing final rinse temperature is achieved regardless of the incoming water temperature, even if connected to a cold water line, by automatically extending the wash cycle (if necessary) to provide additional heating time. Listed rack capacity assumes use of recommended 140°F (60°C) water supply. Exact rack capacity is dependent upon the incoming water temperature and on the electrical supply voltage.

**Note: All specifications are subject to change without notice based on MEIKO's dedicated product improvement program.**

