



K-64 SERIES

**HOT WATER SANITIZING
MULTIPLE-TANK
RACK CONVEYOR
DISHWASHERS**

The clean solution

Special Features:

- **Synchronized side-drive dual rack rail pawl-bar system** ensures complete water coverage from every angle, even the bottom of the rack
- **Large, insulated front door** is spring-loaded to open easily and STAY open, without latching
- **Optimally-positioned wash arms** in easily-removed assemblies. Arms and assemblies are stainless steel, eliminating high-wear gaskets and O-rings
- **Concave, slotted nozzles** minimize clogging. Nozzles are optimally-positioned at varying angles to maximize water coverage over all areas of the ware
- **Powerful 3hp wash pumps** are 50% more powerful than the industry standard for outstanding cleaning
- **Large separation between wash and rinse** (14"/356mm upper, 15"/381mm lower) avoids splashing of soiled water onto sanitized ware
- **Front-sloping tanks** for complete drainage and easier cleaning
- **External, easily-operated lever drain system** makes draining fast, safe and simple

Standard Features:

- Capacity **284** racks per hour
- Water consumption **0.37** gallons (1.40 liters) per rack
- 304-series stainless steel construction
- Double-wall insulated construction on front, top and back to improve operator safety, conserve heating energy, and reduce noise and heat loss into the dishroom
- Large, easily-removed pan strainers
- Fully automatic operation including auto-fill and auto-start. Wash, recirculating rinse and final rinse are activated only when a rack is in place to conserve water and detergent
- Powerful 3hp (2.2 kW) wash and recirculating rinse pumps are vertically-mounted to be self-draining and easily removed for servicing
- Electromechanical controls for reliability and easy operation. Low-voltage 24VAC control circuit for operator safety
- Easily accessible detergent and rinse aid injection ports for fast and easy chemical dispenser installation
- Single-point electrical, water and drain connections. Internal booster heater option adds an additional terminal block for simpler replacement of an existing external booster heater
- Low-level heater protection
- External vent fan control
- Pressure reduction valve (machines with internal booster heater)



Options:

- Choice of two clearance heights (standard 18"/457mm or tall hood 26"/660mm)
- Internal booster heater (steam or electric heat)
- External booster heater (steam or electric heat)
- Table limit switch (end stop or whisker switch versions)
- Vent cowl collars
- Direct drive sideloader
- 90° powered loader or unloader
- Flanged feet
- Drain water tempering kit
- Shock arrestor
- Pressure reduction valve (machines without internal booster heater)

Models:

- K-64E: 18" vertical clearance, electric heat
- K-64S: 18" vertical clearance, steam coil heat
- K-64ET: 26" vertical clearance, electric heat
- K-64ST: 26" vertical clearance, steam coil heat

This dishwasher is compliant with the Reduction of Lead in Drinking Water Act (2011) amendment to the Safe Drinking Water Act (SDWA).



K-64 Series, left-to-right - electric heat w/o internal booster *OR* steam heat (all)

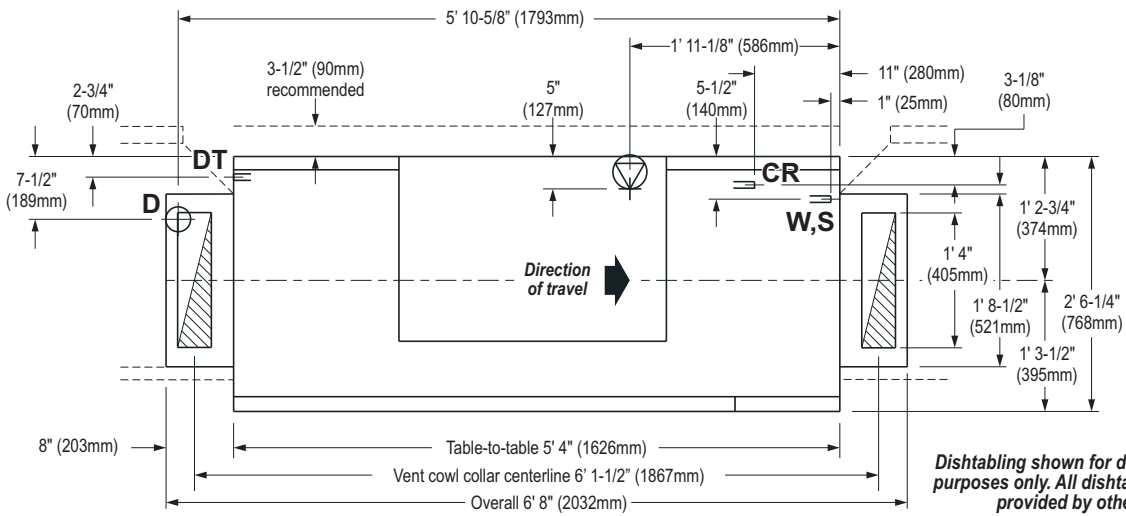
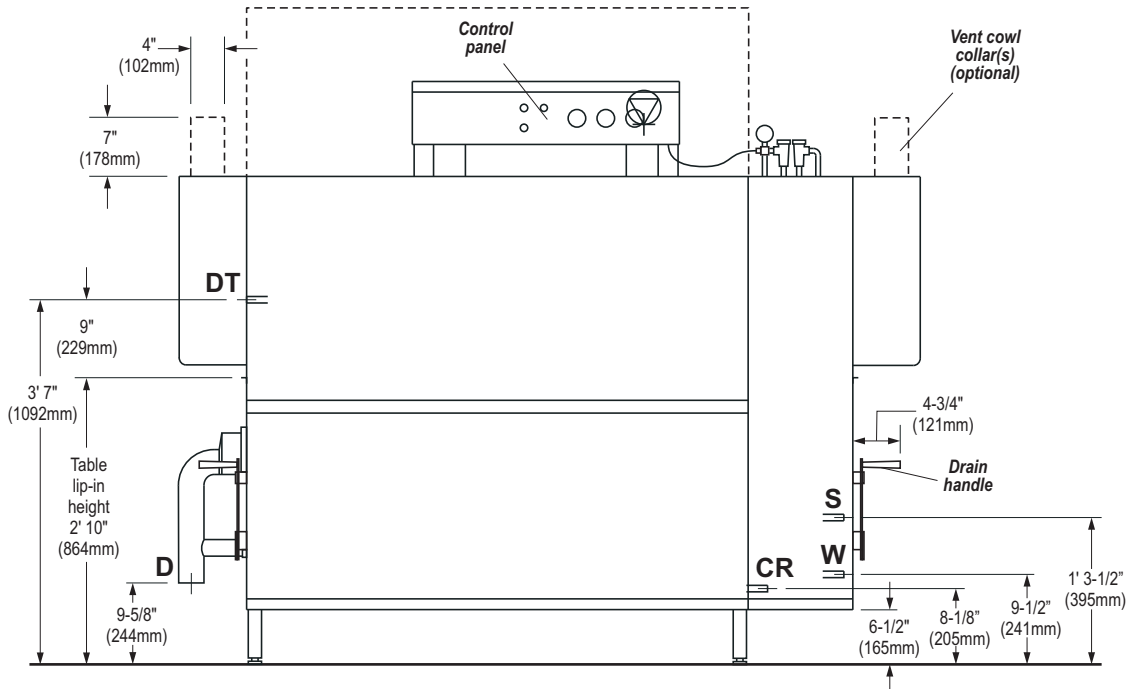

Dishtabling shown for dimensional purposes only. All dishtabling is provided by others.

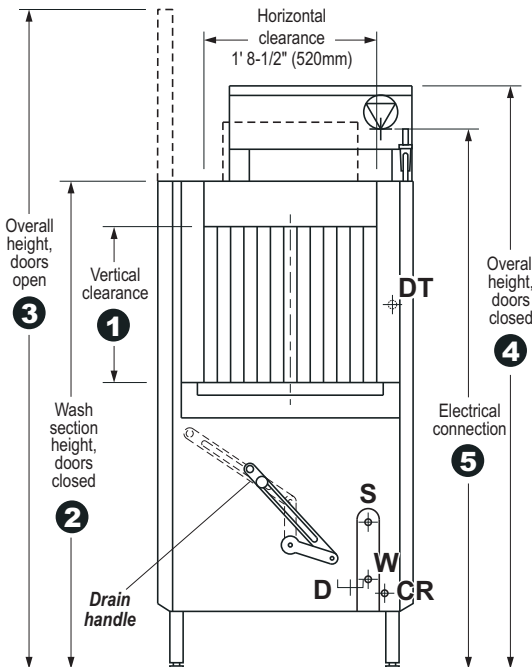

Variable Dimensions

All dimensions from floor are +/- 1/2" due to adjustable feet.

	Standard height machines	Tall hood machines
①	1' 6" (457mm)	2' 2" (660mm)
②	4' 9-7/8" (1471mm)	5' 5-7/8" (1673mm)
③	6' 7-7/8" (2030mm)	7' 11-7/8" (2435mm)
④	5' 9-1/8" (1756mm)	6' 5-1/8" (2435mm)
⑤	5' 4" (1626mm)	6' (1829mm)

Utility Connection Symbols

Utility ratings and connection specifications on Page 6.

- D** Drain
- W** Water
- DT** Detergent
- E** Electrical
- S** Steam
- IMPORTANT:** Ensure tabling does not block detergent port!
- V** Ventilation
- CR** Condensate return

K-64 Series, right-to-left - electric heat w/o internal booster OR steam heat (all)

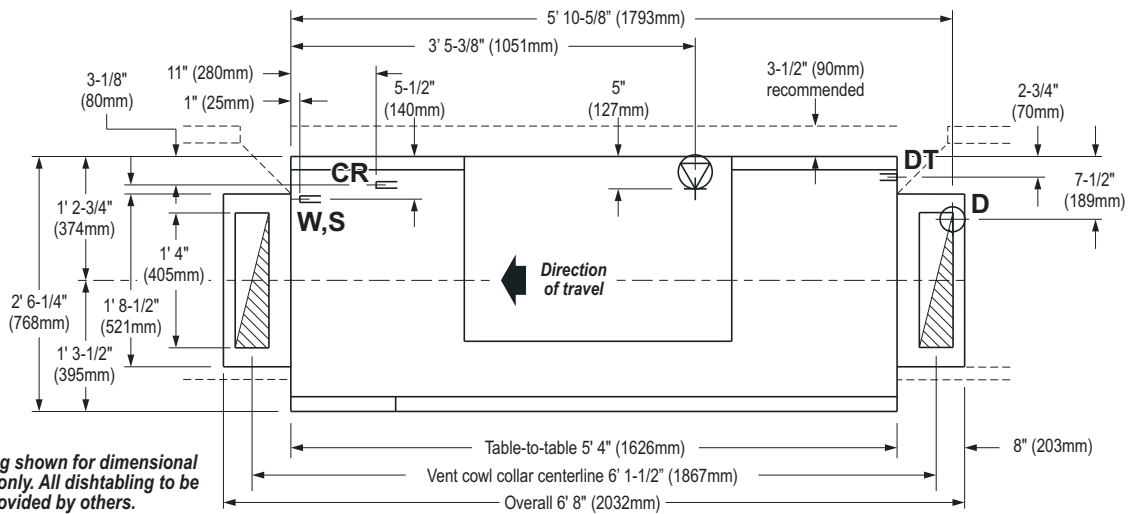
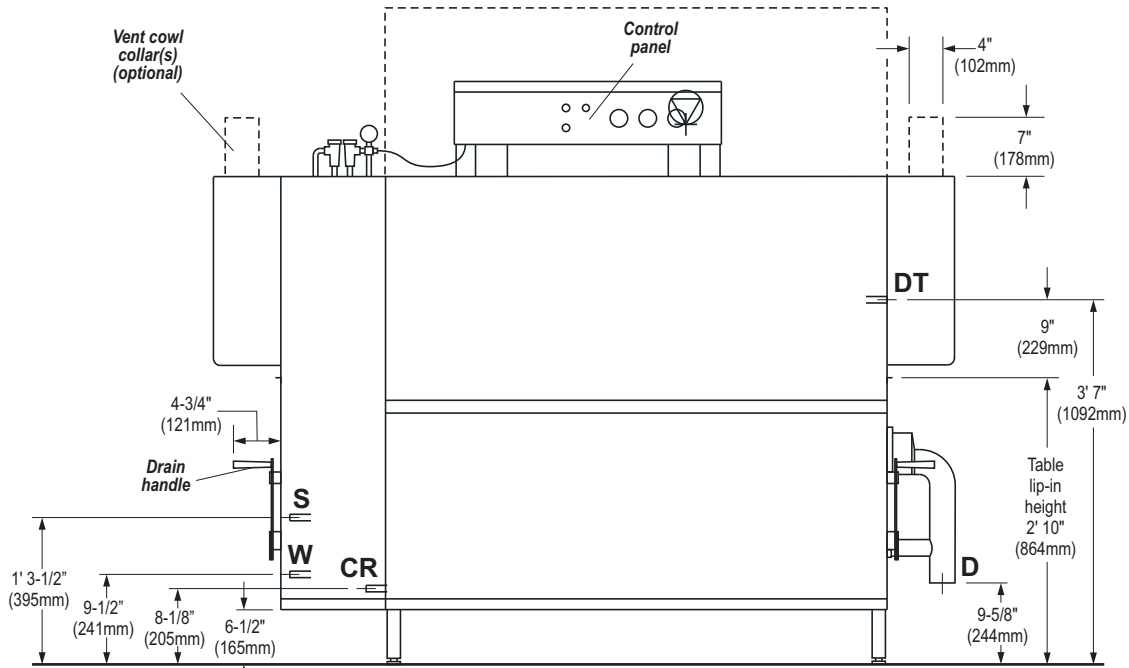

Disabling shown for dimensional purposes only. All disabling to be provided by others.

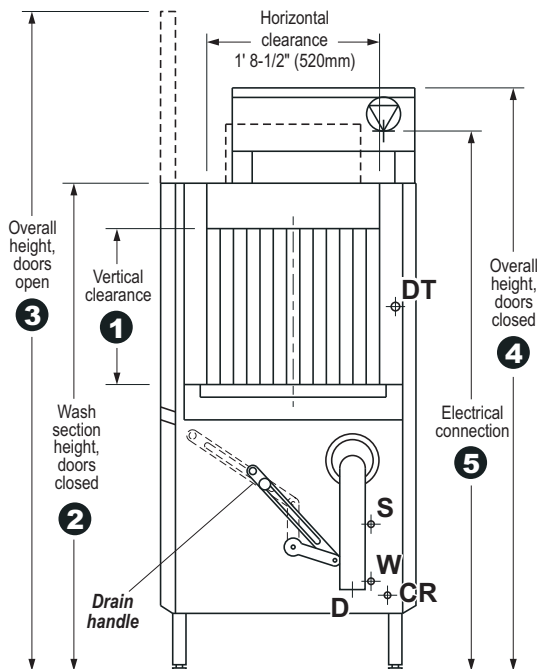

Variable Dimensions

All dimensions from floor are +/- 1/2" due to adjustable feet.

	Standard height machines	Tall hood machines
①	1' 6" (457mm)	2' 2" (660mm)
②	4' 9-7/8" (1471mm)	5' 5-7/8" (1673mm)
③	6' 7-7/8" (2030mm)	7' 11-7/8" (2435mm)
④	5' 9-1/8" (1756mm)	6' 5-1/8" (2435mm)
⑤	5' 4" (1626mm)	6' (1829mm)

Utility Connection Symbols

Utility ratings and connection specifications on Page 6.

- D** Drain
 - W** Water
 - DT** Detergent
 - E** Electrical
 - S** Steam
 - V** Ventilation
 - CR** Condensate return
- IMPORTANT:** Ensure tabling does not block detergent port!

K-64 Series, left-to-right - electric heat with internal booster

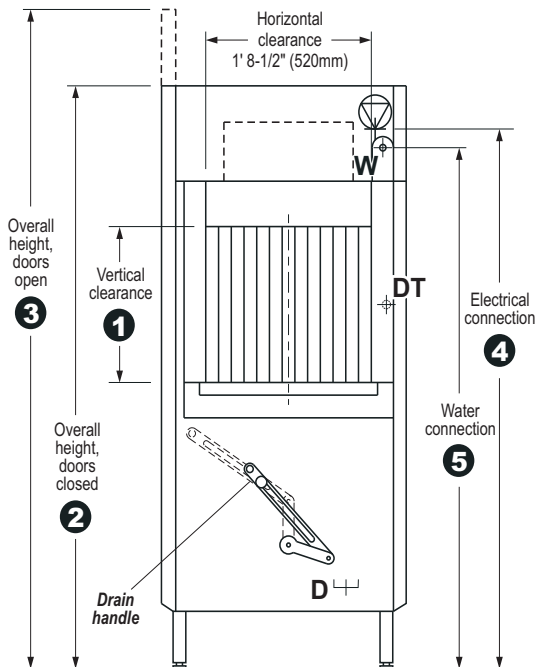
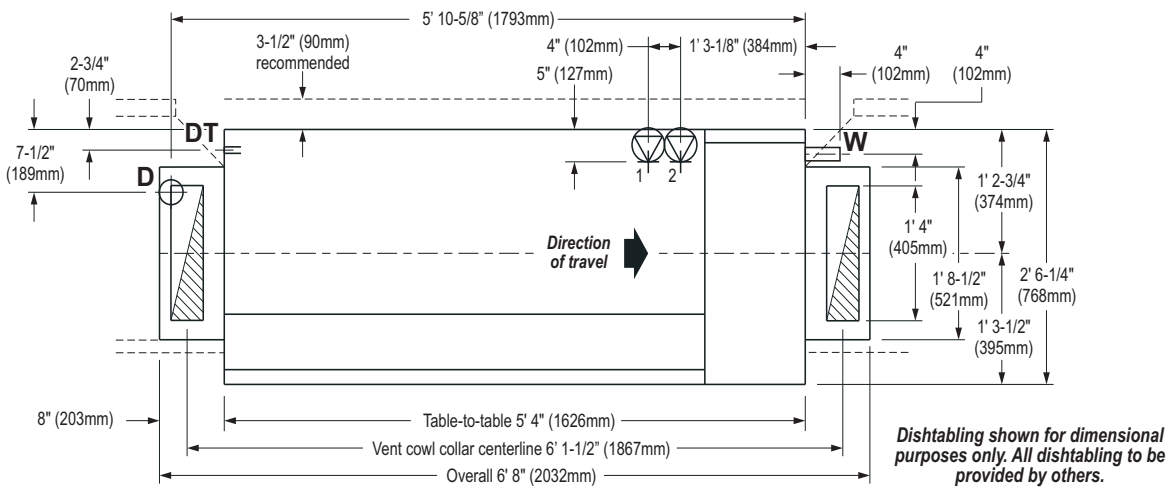
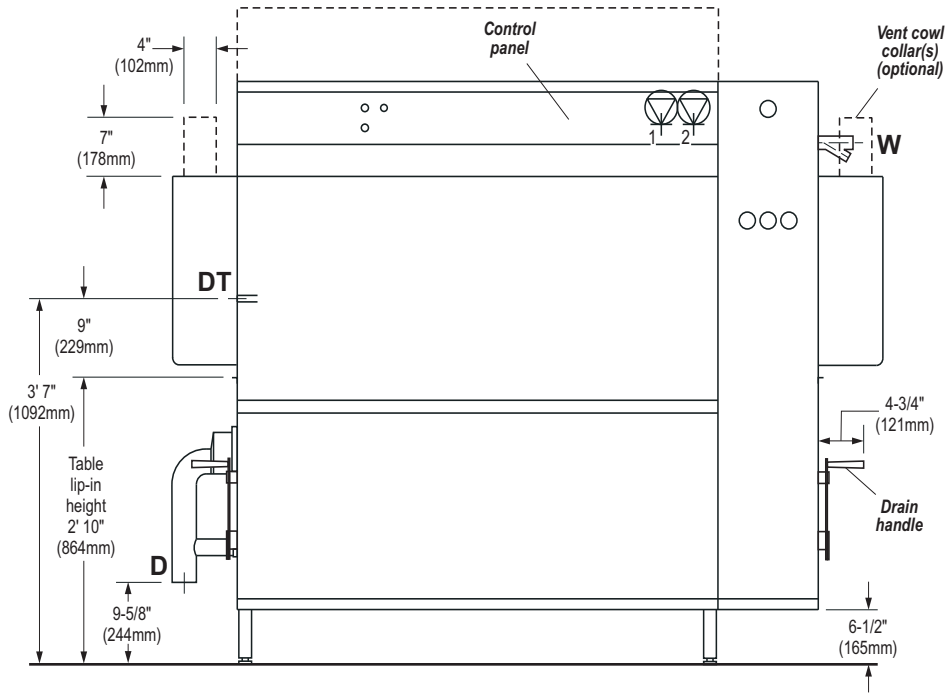

Variable Dimensions

All dimensions from floor are +/- 1/2" due to adjustable feet.

	Standard height machines	Tall hood machines
①	1' 6" (457mm)	2' 2" (660mm)
②	5' 9-1/8" (1756mm)	6' 5-1/8" (2435mm)
③	6' 7-7/8" (2030mm)	7' 11-7/8" (2435mm)
④	5' 4" (1626mm)	6' (1829mm)
⑤	5' 2" (1576mm)	5' 10" (1778mm)

Utility Connection Symbols

Utility ratings and connection specifications on Page 6.

- D** Drain
 - W** Water
 - DT** Detergent
 - Electrical
 - Ventilation
- IMPORTANT:** Ensure tabling does not block detergent port!

K-64 Series, right-to-left - electric heat with internal booster

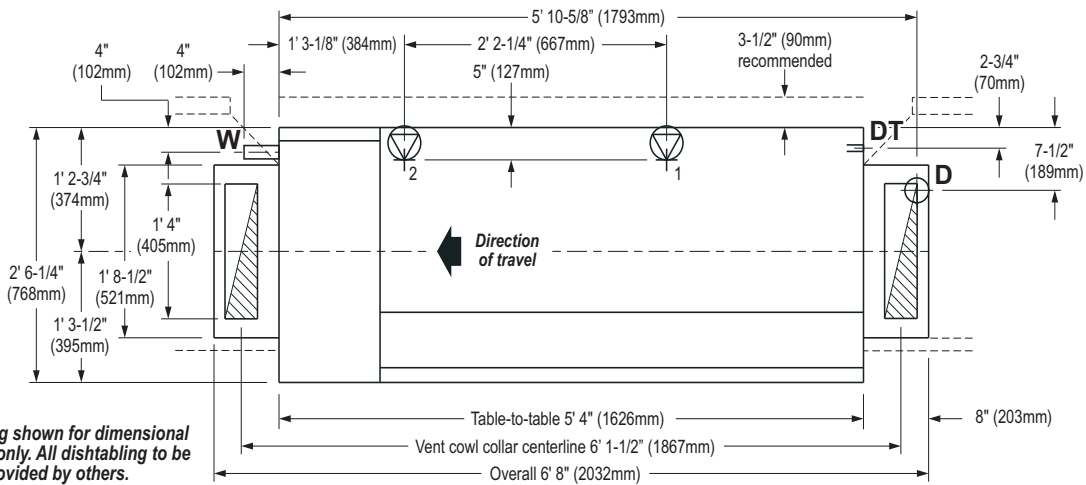
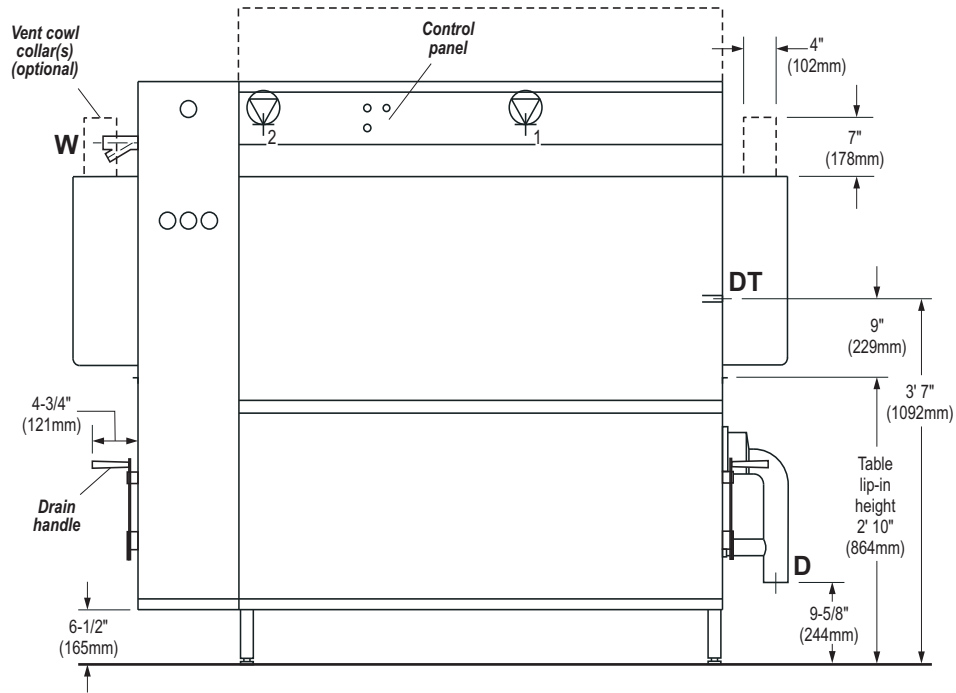

Disabling shown for dimensional purposes only. All disabling to be provided by others.

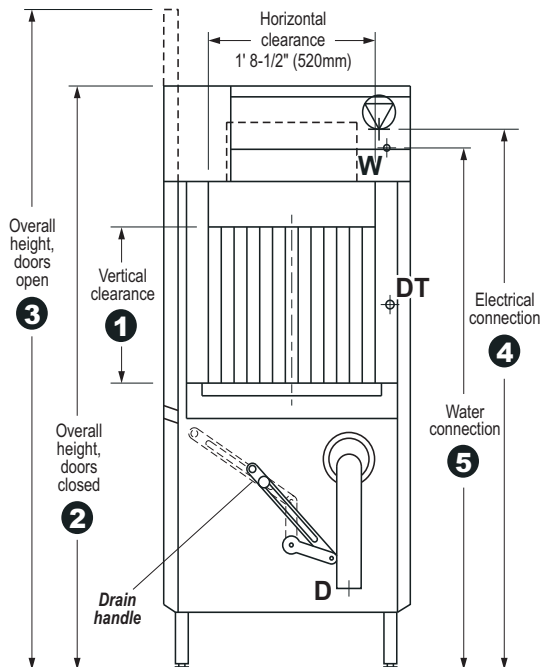

Variable Dimensions

All dimensions from floor are +/- 1/2" due to adjustable feet.

	Standard height machines	Tall hood machines
①	1' 6" (457mm)	2' 2" (660mm)
②	5' 9-1/8" (1756mm)	6' 5-1/8" (2435mm)
③	6' 7-7/8" (2030mm)	7' 11-7/8" (2435mm)
④	5' 4" (1626mm)	6' (1829mm)
⑤	5' 2" (1576mm)	5' 10" (1778mm)

Utility Connection Symbols

Utility ratings and connection specifications on Page 6.

- D** Drain
 - W** Water
 - DT** Detergent
 - Electrical** (Symbol)
 - Ventilation** (Symbol)
- IMPORTANT:** Ensure tabling does not block detergent port!

K-64 Series Utility Connections

D Drain

2-15/16" (75mm) OD vertical, gravity-fed drain outlet (HDPE piping). Recommend placement directly above 4" floor drain. Additional piping to drain (if so required) to be supplied by customer.

Connection is 9-5/8" (244mm) AFF. If using optional 2" NPT adapter, connection is 8-1/2" (214mm) AFF. Refer to **Detail View: Drain** for suggested connection.

Single electrical connection

• Single terminal block inside control box (4-wire with ground - no neutral).

Dual electrical connections - machines with internal electric booster heater

• Two terminal blocks inside control box (4-wire with ground - no neutral).

- 1 - Machine electrical supply
- 2 - Booster heater electrical supply

Electrical supply (or supplies) should be routed into control box through strain relief(s) on rear of control box. Incoming leads must be appropriately sized for electrical supply. Individual disconnect with lockout/tagout strongly recommended (provided by customer).

Connection for standard-height machines is 5' 4" (1626mm) AFF. Connection for tall hood machines is 6' (1829mm) AFF.

Refer to utility chart on Page 7 for electrical load information.

Vent connection - machines with optional vent cowl collars

Refer to **Detail View: Vent** for suggested connection.

The waste air connection must be corrosion-resistant and frost-free. In particular, provisions must be made to prevent air temperatures of 32°F/0°C or colder from reaching the machine at any time. A provision for draining moisture from the waste air pipe is strongly recommended.

- Load end - 150 CFM (255 m³/h)
- Unload end - 150 CFM (255 m³/h)
- Total - 300 CFM (510 m³/h)

DT Detergent

Connection is 3' 7" (1092mm) AFF. Provided dummy plug covers hole for external detergent line.

IMPORTANT: Ensure tabling does not block detergent port!

W Hot water connection - machines without internal booster heater

1/2" NPT female pipe connection is 9-1/2" (241mm) AFF.

- Temperature 180°F (82°C)
- Pressure 15-25 PSI (1.0-1.7 bars)
- Initial fill 41.0 U.S. gals. (155.2 liters)
- Consumption 105.0 U.S. gals per hour (397.5 liters) per hour
- Recommended hardness 1-6 grains/U.S. gal.

W Water connection - machines with internal booster heater only

For steam heat, 1/2" NPT female pipe connection is 9-1/2" (241mm) AFF.

For electric heat, 1/2" NPT female pipe connection is 5' 2" (1576mm) AFF for standard-height, 5' 10" (1778mm) AFF with tall hood option.

- Temperature:
 - Machines with 40°F booster: 140°F (60°C)
 - Machines with 70°F booster: 110°F (43°C)
- Pressure 15-25 PSI (1.0-1.7 bars)
- Initial fill 41.0 U.S. gals. (155.2 liters)
- Consumption 105.0 U.S. gals per hour (397.5 liters) per hour
- Recommended hardness 1-6 grains/U.S. gal.

S Steam connection - steam-heated machines

Pipe connection is 1' 3-1/2" (395mm) AFF.

- Machines without internal steam booster heater: 3/4" male NPT connection
- Machines with internal steam booster heater: 1-1/4" male NPT connection
- 10-30 PSI CONSTANT steam pressure is REQUIRED. If pressure is above 30 PSI, use of a regulator is REQUIRED (supplied by customer).
- The pipe connection does NOT reflect the steam line size from the boiler to the dishwasher. The necessary steam line sizing must be determined by the facility's steam engineer based on the pressure and volume requirements.
- Consumption: Refer to utility chart on Page 7

CR Condensate return connection - steam-heated machines

3/4" NPT male pipe connection is 8-1/8" (205mm) AFF. Condensate line MUST be pressure-free.

Vent Connection

Machines equipped with optional vent cowl collars may be installed underneath a ventilation hood, or may use "pant leg" ventilation ducts (to be supplied by the customer). To determine the dimensions of the duct, first determine how they will be installed:

• Duct sleeved outside collar

Inside dimensions of duct: 4" W x 16" D (102 x 406mm).

• Duct sleeved inside collar

Outside dimensions of duct: 3-3/4" W x 15-3/4" D (95 x 400mm).

The duct must not interfere with the adjustable baffle, as shown.

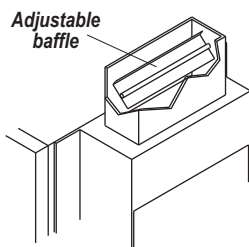

Duct sleeved outside collar (recommended)

4" x 16" (102x406mm) inside dimensions

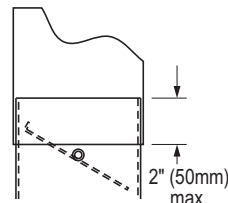

Duct sleeved inside collar (if required)

3-3/4" x 15-3/4" (95x400mm) outside dimensions

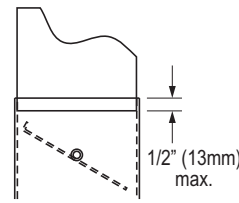

Drain Connection

The machine is equipped with a 2-15/16" (75mm) OD vertical, gravity-fed drain. If possible, the machine drain can simply be positioned directly above a 4" floor drain.

If a floor drain is not in the correct location, or if local codes require a trap, a 2" indirect drain line may be attached using the supplied 2" NPT male adapter.

Choose a piping material that:

- Complies with any applicable local and national codes
- Is rated for use with water temperatures up to 180°F/82°C
- Is rated for 3-12 pH to accommodate detergents and rinse aid in the drain water

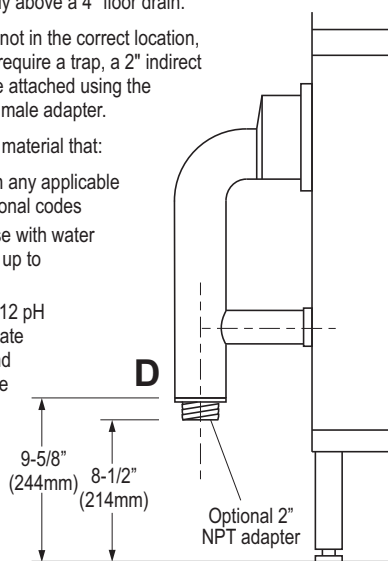

Recommended Tabling Construction

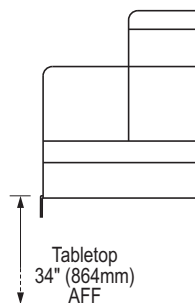

Check that the table lip overlaps BOTH the inner and outer panels.

Use silicone sealer between the table lip and the machine to prevent leakage.

IMPORTANT: Ensure tabling does not block detergent port!

Ensure that the detergent supply tube can be routed to the injection port. A vertical tapered rear edge to the backsplash (without an angled top) is recommended.

Angled top on tapered section not recommended

All dishtabing by others

20-1/4" (515mm) recommended

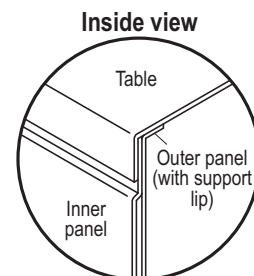
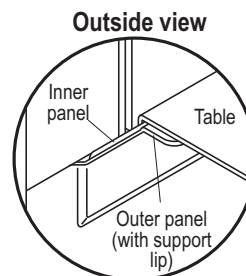

K-64 Series Technical Specifications

Operating Capacities (NSF Rated)

Racks per hour	284
Dishes per hour	7,100
Glasses per hour	10,224

Conveyor Specifications

Conveyor belt speed	7.91 feet/min. (2.41m/min.)
Horizontal clearance	1' 8-1/2" (520mm)
Vertical clearance (K-64E, K-64S)	1' 6" (457mm)
Vertical clearance (K-64ET, K-64ST)	2' 2" (660mm)

This machine may not pass through standard doorways without machine disassembly or doorway modification. Check all dimensions carefully prior to ordering, or contact MEIKO at sales@meiko.us for assistance.

Venting Specifications

Load end	150 CFM (255m ³ /h)
Unload end	150 CFM (255m ³ /h)
Total	300 CFM (510m ³ /h)

Shipping Information

K-64E, K-64S:	
Shipping weight	749 lbs. (340kg)
Crating (LxWxH)	98" x 46" x 75" (2489 x 1168 x 1905mm)
K-64ET, K-64ST:	
Shipping weight	829 lbs. (376kg)
Crating (LxWxH)	98" x 46" x 85" (2489 x 1168 x 2159mm)

Some options and accessories may affect shipping weight or dimensions. Contact MEIKO at sales@meiko.us for assistance.

Water Specifications

Minimum water temperatures:	
Wash tank	150°F (66°C)
Recirculating rinse tank	160°F (72°C)
Final rinse	180°F (82°C)
Minimum incoming water temperature:	
Machines without internal booster	180°F (82°C)
Machines with internal booster	110° or 140°F (43° or 60°C)
Initial fill	41.0 U.S. gals. (155.2 liters)
Wash tank capacity	20.5 U.S. gals. (77.6 liters)
Recirculating rinse tank capacity	20.5 U.S. gals. (77.6 liters)

Incoming water line size	1/2" NPT
Recommended water hardness	1-6 grains/U.S. gal.
Consumption at 100% capacity:	105.0 U.S. gals. (397.5 liters)/hr. 0.37 U.S. gals. (1.40 liters)/rack
Final rinse flow pressure	15-25 PSI (1.0-1.7 bars)
Flow rate	1.75 U.S. gals.(6.62 liters)/min.
Drain line size	2-15/16" (75mm) OD, 2" NPT adapter supplied
Maximum drain flow rate	15 gals. (56.8 liters) per minute

Electrical Specifications

Machine supply connection	Peak current draw	Minimum supply circuit ampacity	Maximum breaker/disconnect
K-64E, K-64ET (standard height and tall hood, electric tank heat)			
208V/60 Hz/3 Ph	85.4 A	110 A	110 A
230V/60 Hz/3 Ph	77.2 A	100 A	100 A
460V/60 Hz/3 Ph	38.3 A	50 A	50 A
K-64S, K-64ST (standard height and tall hood, steam coil tank heat)			
208V/60 Hz/3 Ph	18.7 A	25 A	25 A
230V/60 Hz/3 Ph	18.7 A	25 A	25 A
460V/60 Hz/3 Ph	8.2 A	15 A	15 A
Wash pump motor	3.0 hp (2.2 kW)		
Recirculating rinse pump motor	3.0 hp (2.2 kW)		
Conveyor motor	0.125 hp (0.09 kW)		

Internal booster heater supply connection	Rating, machine startup	Rating, machine operation	Peak current draw	Minimum supply circuit ampacity	Maximum breaker/disconnect
40°F rise electric booster (140°F/60°C water supply temperature)					
208V/60 Hz/3 Ph	18.0 kW	10.8 kW	50.0 A	70 A	70 A
230V/60 Hz/3 Ph	18.0 kW	10.8 kW	45.0 A	60 A	60 A
460V/60 Hz/3 Ph	18.0 kW	10.8 kW	22.6 A	30 A	30 A
70°F rise electric booster (110°F/43°C water supply temperature)					
208V/60 Hz/3 Ph	28.8 kW	21.6 kW	79.9 A	100 A	100 A
230V/60 Hz/3 Ph	28.8 kW	21.6 kW	72.3 A	100 A	100 A
460V/60 Hz/3 Ph	28.8 kW	21.6 kW	36.1 A	50 A	50 A
Electric tank heater ratings (K-64E, K-64ET)					
	208V/60Hz/3Ph	230V/60Hz/3Ph	460V/60Hz/3Ph		
Wash tank	15.0 kW	14.6 kW	15.0 kW		
Recirculating rinse tank	9.0 kW	8.8 kW	9.0 kW		

Steam Specifications (K-64S, K-64ST)

Steam line connection:	
Machines without internal steam booster heater	3/4" NPT
Machines with internal steam booster heater	1-1/4" NPT
Condensate return connection	3/4" NPT
Steam pressure	10-30 psi (0.7-2.0 bars)
Steam consumption:	
Tank heat	60 lbs./hr.
40°F rise steam booster (140°F/60°C water supply temperature)	+50 lbs./hr.
70°F rise steam booster (110°F/43°C water supply temperature)	+100 lbs./hr.

External Booster Heater Recommendations (for machines without optional internal booster heater)

Booster ratings are based on peak capacity of 105.0 U.S. gals. (397.5 liters) per hour and a flow rate of 1.75 U.S. gals. (6.62 liters) per minute. Recommended boosters are one size larger than required to help compensate for any local conditions that may prevent full performance.

Water supply temperature	Required temperature rise	Recommended booster rating
110°F/43°C	70°F/39°C	24 kW
140°F/60°C	40°F/22°C	12 kW

Note: All specifications are subject to change without notice based on MEIKO's dedicated product improvement program.

Equipment Specification: K-64 Rack Conveyor Dishwasher- Item No. _____

Item will be an NSF and ETL-listed MEIKO K-64 multiple tank, rack conveyor dishwasher, consisting of a wash zone with 3 hp (2.2 kW) pump motor, a recirculating rinse zone with 3 hp (2.2 kW) pump motor, and a final rinse zone. Total length of the tank section (not including vent cowls) will be 5' 4" (1626mm). Unit will utilize a 180°F/82°C minimum fresh water sanitizing rinse.

Unit will have a capacity of 284 racks per hour at an NSF-rated belt speed of 7.91 feet (2.41m) per minute. Unit will consume an NSF-rated 105.0 U.S. gals./397.5 liters per hour (0.37 U.S. gals./1.40 liters per rack).

Electrical characteristics:

208V/60 Hz/3 Ph

230V/60 Hz/3 Ph

460V/60 Hz/3 Ph

Wash tank temperature will be maintained at a minimum of 150°F/66°C. Recirculating rinse tank temperature will be maintained at a minimum of 160°F/72°C. Tank heating will be accomplished by:

Thermostatically-controlled electric heating elements (K-64E, K-64ET)

Thermostatically-controlled stainless steel steam coils (K-64S, K-64ST)

Direction of conveyor travel will be:

Right-to-Left

Left-to-Right

Unit will have the following standard features:

- Double-wall, insulated construction on top, front, and rear.
- Four upper wash arms with 15" (381mm) wash area and four lower wash arms with 14" (356mm) wash area.
- Four upper recirculating rinse arms with 15" (381mm) wash area and four lower recirculating rinse arms with 14" (356mm) wash area.
- Wash arm spray pattern ensures effective coverage with varying angles and offset spray jets. Slotted, concave wash nozzles and captivated end caps for easier cleaning.
- Minimum separation between recirculating rinse and final rinse of 14" (356mm) upper and 15" (381mm) lower.
- Synchronized rack rail pawl bar system for smooth rack movement. Side drive system provides easy cleaning access and eliminates wash pattern obstruction.
- Front-sloping tanks for complete tank drainage, accessibility, and cleanability.
- Fully automatic operation including auto-fill and auto-start.
- Separate compartment actuator switches to ensure wash, recirculating rinse and final rinse are energized only when a rack is in place.
- External, easily operable, lever-operated drain system.
- Low level heater protection.
- Wash and recirculating rinse pump motors are self-draining, internal and vertically installed for easy access and serviceability.
- Wash and recirculating rinse pump housings and impellers constructed of stainless steel.
- Electromechanical controls with a 24 VAC control circuit.
- Single point electrical connection.
- Easily removable wash and recirculating rinse arm assemblies, and final rinse arms.
- Large front access door can be opened with one hand and remain open without latches, aiding machine accessibility and cleanability.
- Large, removable stainless pan strainers.
- External vent fan control.
- Single point drain connection.
- Pressure reduction valve (machines with internal booster heater only).

Unit will have the following optional features (check all that apply):

Tall hood option to increase vertical clearance from 1' 6" (457mm) to 2' 2" (660mm)

Internal booster heater (steam or electric per machine spec). Electrically-heated internal booster heater adds 1 electrical terminal block to machine (2 total).

Sized for a minimum 40°F (22°C) rise and 140°F (60°C) min. incoming water temperature

Sized for a minimum 70°F (39°C) rise and 110°F (43°C) min. incoming water temperature

External booster heater

Sized for a minimum 40°F (22°C) rise and 140°F (60°C) min. incoming water temperature

Sized for a minimum 70°F (39°C) rise and 110°F (43°C) min. incoming water temperature

Steam heated

Electrically heated

Table limit switch

Inline (whisker switch) style

End stop style

Vent cowl collar(s) with adjustable damper
4" W x 16" D x 7" H (102x406x178mm)

At both ends

At load end only

At unload end only

90° side loader (unhooded), 23" long

90° side loader (hooded), 23" long

90° power loader, 34-1/4" long

90° power unloader, 34-1/4" long

Flanged, bolt-down feet

Drain water tempering kit

Shock arrestor

Pressure reduction valve (machines w/o int. booster htr. only)