



BEVERAGE-AIR



bc40-4

BLAST CHILLER 40 lbs./PERFORMANCE, AIR-COOLED UNIT

RANGE FEATURES

- Exterior: AISI 304 18-10 stainless steel front, side, rear, and top panels.
Interior: AISI 304 18-10 stainless steel.
- Satin scotchbrite finish on door; side panels, control panel and top. Polished interior.
- UL-NSF Mark.

FUNCTIONAL FEATURES

- Without working top section.
- One-piece construction with rounded internal corners.
CFC-free expanded polyurethane insulation, 2.36" thickness, density 38kg/ m3.
- Hinged fan cover for easy access to the evaporator and fan during cleaning.
- Diamond-polished inner floor for improved hygiene. Drain outlet for easy cleaning of interior.
- Useful for 12" x 20" x 2.5" pans.
- Removable half racks and container support guides in AISI 304 stainless steel, 5 positions, 2.36". vertical spacing intervals.
- Standard supplied: 3 container guides and 1 grid.
- Digital control board with p.c.b.:
 - LCD display 16 columns and 2 stripes to visualize the operating phases;
 - Blast chilling with variable cycle progression;
 - 20 pre-set blast-chilling cycles;
 - opportunity to modulate the ventilation speed combined to one of the pre-set chamber temperatures;
 - HACCP History;
 - 5-languages library;
 - Visualization of the temperature in the chamber, from the temperature at the hart of the product or that of the time during the blast chilling/freezing cycle, of the ventilation speed in the chamber;
 - Automatic setting of the refrigerating phase at the end of the cycle.
- Self-closing door. Full height outer stainless steel handle.
- Depth with door open 54.1". Easily-removable magnetic gasket. Door frame heating element.
- Inner dimensions mm 24.4" (L) x 23.3" (P) x 15.4" (H). Interior capacity 88 litres.
- Plastic defrost drip tray on the outer base.
- Stainless steel feet with plastic heat-resistant pads, height adjustable from 4.5" to 6.5".
- Standard supplied product core probe with L-shaped handle for easy extraction.

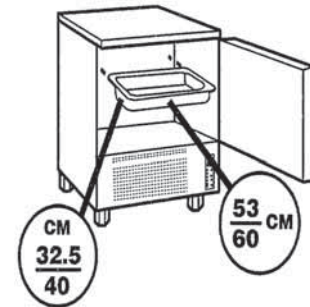

TECHNICAL FEATURES

- Cooling unit at evaporation temperature +14°F and condensation temperature +128°F rated at 692 Watt with hermetic compressor.
- Refrigerant gas: R404A. Air cooling. Production per cycle: 40 lbs. From +194°F to +37.4°F in 90 minutes. Tropicalized at 90°F (climate class N or 4 ISO441).
- Preset inner cell temperature +14°F. Evaporation temperature control with thermostat valve.
- Internal operation: ventilated cell. Copper/aluminum rustproofed evaporator. Manual defrosting.
- All controls and parts accessible from the upper part of the appliance.

Width: inch. 29.5
Depth: inch. 27.5
Height: inch. 35.8
Net weight: lbs. 255

Electric Power: KW 0.9

Standard connection: V-HZ 220V 60Hz 1Ph

www.beverage-air.com

p.o. box 5932, spartanburg, sc 29304 u.s.a. phone 1.888.845.9800 fax 1.864.582.5083 sales@bevair.com

