



BEVERAGE-AIR

3779 Champion Blvd., Winston-Salem, NC 27105
1-888-845-9800 Fax# 1-336-245-6453
<http://www.Beverage-Air.com>

Commercial Refrigeration Equipment General Specification

3 Year Parts/Labor Warranty Additional 2 Year Compressor Warranty

CR5 SERIES—COUNTERTOP REFRIGERATOR

Select from 6 standard models. Used for merchandising and storage of product. Requires minimum countertop space.

CABINET CONSTRUCTION

Heavy duty construction includes baked on white epoxy exterior finish. Stainless steel finish available. Top frame includes lighted sign panel. Door frames are constructed of anodized aluminum.

2" foamed-in-place CFC free polyurethane insulation enhances the structural strength of the cabinet and helps increase energy efficiency.

Field reversible, triple pane tempered glass doors feature heated hinged glass doors. Pass-thru models feature a door on each side for ease of product loading.

Glass end models feature one glass panel per side for enhanced product display.

REFRIGERATION

Forced-air refrigeration system uses R134a refrigerant, which is CFC free for compliance with environmental safety concerns. Operating temperatures as low as 35°F (2°C).

ELECTRICAL

Interior fluorescent lighting enhances product illumination. Units wired at factory and ready for connection to a 115/60/1 phase, 15 amp dedicated outlet. 8' long cord and plug set included.

SPECIAL FEATURES

- Door locks available
- Lighted sign panel standard
- Pass-thru models available
- Glass end models enhance product visibility.

ELECTRICAL CONNECTION

Units pre-wired at factory and include 8' long cord and plug set.



115/60/1
NEMA-5-15P

Item No. _____
Quantity _____

COUNTERTOP MERCHANDISER SERIES C SERIES REFRIGERATOR

MODELS:
CR5
CR5GE
CRD5
CRD5GE

CRD5



CR5



CRD5



Available From:



*Note: Not all markings may apply to all model variations.

Model Specified _____	Store# _____
Location _____	Quantity _____



PLAN VIEWS

Countertop Merchandiser Series Models: CR5, CR5GE, CRD5, CRD5GE

MODEL	CR5	CR5GE	CRD5	CRD5GE
EXTERNAL DIMENSIONAL DATA				
Length Overall (inches)	22"	22"	22 1/8"	22 1/8"
Length Overall (mm)	559	559	562	562
Depth Overall (inches)	24"	24"	25 1/4"	25 1/4"
Depth Overall (mm)	610	610	641	641
Height Overall— (inches)	39 5/8"	39 5/8"	39 1/2"	39 1/2"
Height Overall— (mm)	1007	1007	1003	1003
Number of doors	1	1	2	2
Depth with Door Open 90 °	41 1/8"	41 1/8"	65 1/2"	65 1/2"
Clear Door Opening (inches)	17 3/8" x 20 1/2"	17 3/8" x 20 1/2"	17 1/2" x 20 3/8"	17 1/2" x 20 3/8"
INTERNAL DIMENSIONAL DATA				
NET Capacity (cubic ft.)	5	5	5.5	5.5
NET Capacity (Liters)	142	142	156	156
Internal Length Overall (inches)	17 3/4"	17 3/4"	17 3/4"	17 3/4"
Internal Length Overall (mm)	451	451	451	451
Internal Depth Overall (inches)	19 3/8"	19 3/8"	21 1/2"	21 1/2"
Internal Depth Overall (mm)	492	492	546	546
Internal Height Overall—(inches)	23 1/2"	23 1/2"	23 1/2"	23 1/2"
Internal Height Overall—(mm)	597	597	597	597
Number of shelves	3	3	3	3
ELECTRICAL DATA				
Full Load Amperes 115/60/1	5.9	5.9	5.9	5.9
ENERGY CONSUMPTION (KWH)	3.25	3.25	4.74	4.74
REFRIGERATION DATA				
Horsepower	1/4	1/4	1/4	1/4
WEIGHT DATA				
Gross Weight (Crated lbs)	220	208	222	222
Gross Weight (Crated kg)	100	94	101	101

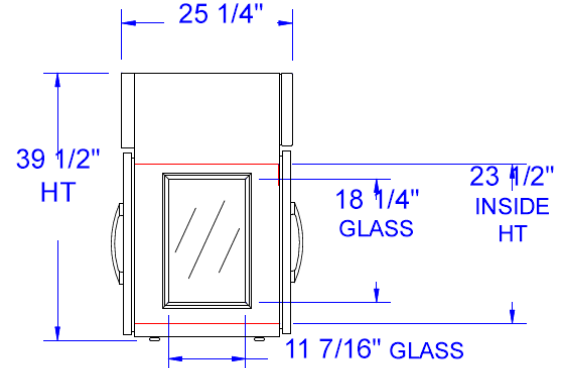

END VIEW

CRD5GE

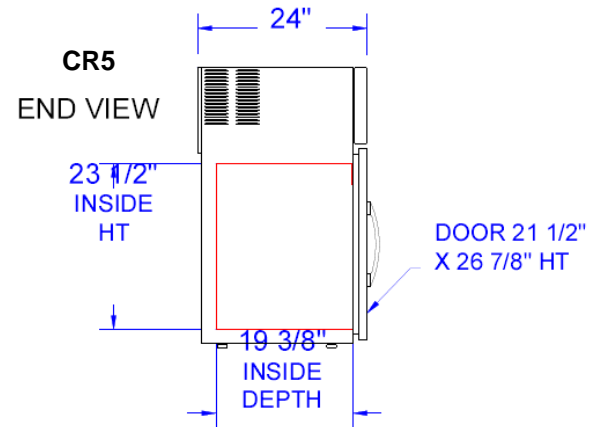

CR5

END VIEW



Note: Not all markings may apply to all model variations.

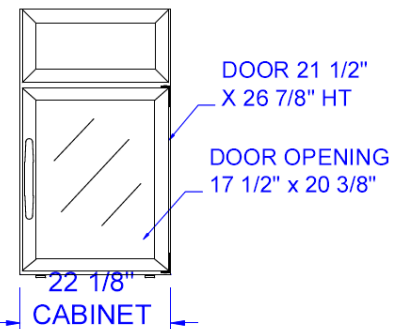

CRD5
FRONT VIEW

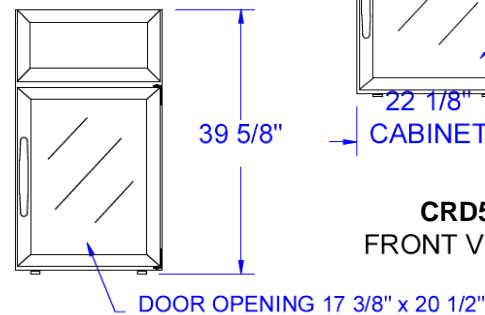

FRONT VIEW

CR5

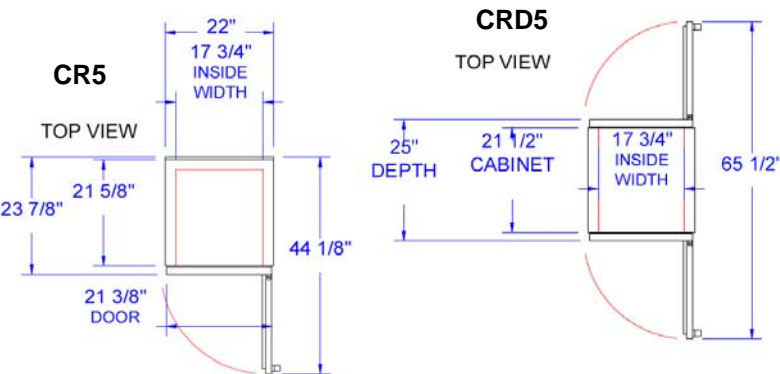

BEVERAGE-AIR® CORPORATION

3779 Champion Blvd. • Winston-Salem, NC 27105 USA • (336) 245-6400 • Fax (336) 245-6453 • (888) 845-9800 • www.beverage-air.com

Specifications are subject to change without prior notice. 07/13