



BEVERAGE-AIR

3779 Champion Blvd., Winston-Salem, NC 27105
1-888-845-9800 Fax# 1-336-245-6453
<http://www.Beverage-Air.com>

Item No. _____
Quantity _____

**DZ24 SERIES
DUAL-ZONE
BAR MOBILE**

**MODELS:
DZ24-1-B
DZ24-1-S**

Commercial Refrigeration Equipment General Specification

3 Year Parts/Labor Warranty Additional 2 Year Compressor Warranty

DZ24 SERIES—DUAL-ZONE BAR MOBILE

The DZ24 provides mobility with application (home, club, hospitality). With full keg capacity and heavy-duty, forced air refrigeration, beer is dispensed ice cold every time.

CABINET CONSTRUCTION

Standard construction includes wear resistant, black vinyl on steel exteriors. Stainless finish options available.

Top is made of heavy-duty stainless steel including drip dray for easy cleaning. Black glass rails standard. Four-inch (4") heavy-duty swivel casters are standard.

Three-inch (3") insulated tower with dual faucet is included.

Left hand compartment maintains 35-60° F, Right hand maintains 40-60° F
Holds (4) 1/6 size kegs

Inside construction utilizes galvanized steel for walls and ceiling. Reinforced floors and doorsill are made from heavy-duty stainless steel to provide lasting service. Door with lock standard. Magnetic gasket provides positive door sealing.

Cabinet insulation is foamed-in-place polyurethane (CFC free) which helps to provide maximum operating efficiency and strengthen the overall construction.

Includes beer waste bottle to capture beer from drain.

REFRIGERATION

CFC-free R134a refrigerant used in Barmobiles to comply with all environmental concerns.

ELECTRICAL

Units wired at factory and ready for connection to a 115/60/1 phase, 15 amp dedicated outlet. 8' long cord and plug set included.

SPECIAL FEATURES

- 100% portable with waste bottle to capture beer from drain
- Black or stainless steel exterior models. Stainless exterior model is the ONLY bar mobile in the industry certified for outdoor use
- 1-4 Tap insulated stainless towers/taps available



DZ24
shown with optional 4 tap tower

***Note:** Overall heights of casters may vary with different types of casters depending upon caster manufacturer designations.

Available From:



Model Specified _____

Store# _____

Location _____

Quantity _____



BEVERAGE-AIR

DZ24 SERIES DUAL-ZONE BAR MOBILE

Models: DZ24-1-B, DZ24-1-S

MODEL	DZ24-1-B	DZ24-1-S
EXTERNAL DIMENSIONAL DATA		
Length Overall (inches)	24"	24"
Length Overall (mm)	610	610
Depth Overall (inches)	29 1/2"	29 1/2"
Depth Overall (mm)	749	749
Height Overall—on casters (inches)*	39.36"	39.36"
Height Overall—on casters (mm)*	1000	1000
Clear Door Opening (inches)	21 9/16" x 29 5/8" HT 19 3/4" x 27 3/4" HT	21 9/16" x 29 5/8" HT 19 3/4" x 27 3/4" HT
Depth With Door Open 90°	48"	48"
Number of doors	1	1
INTERNAL DIMENSIONAL DATA		
NET Capacity (cubic ft.)	7.8	7.8
NET Capacity (Liters)	221	221
Internal Length Overall (inches)	19"	19"
Internal Length Overall (mm)	483	483
Internal Depth Overall (inches)	23 3/4"	23 3/4"
Internal Depth Overall (mm)	603	603
Internal Height Overall (inches)	29 1/2"	29 1/2"
Internal Height Overall (mm)	749	749
Number of Kegs (straight wall)	1	1
ELECTRICAL DATA		
Full Load Amperes 115/60/1	4.0	4.0
REFRIGERATION DATA		
Horsepower	1/5	1/5
WEIGHT DATA		
Gross Weight (Crated lbs)	205	220
Gross Weight (Crated kg)	92	99

*Note: Overall heights of casters may vary with different types of casters depending upon caster manufacturer designations.

PLAN VIEWS

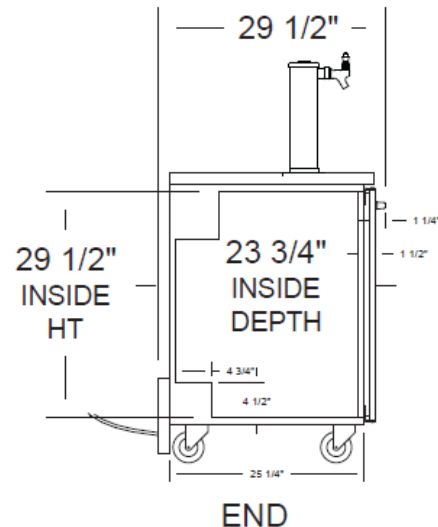
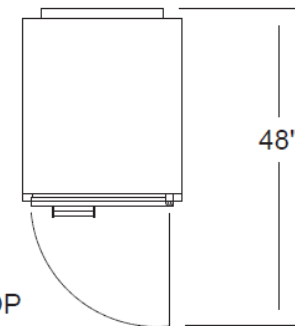
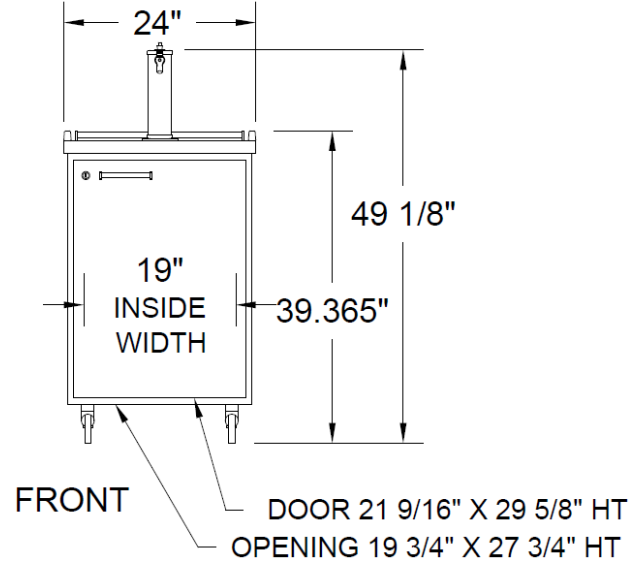

ELECTRICAL CONNECTION

Units pre-wired at factory and include 8' long cord and plug set.



115/60/1
NEMA-5-15P

BEVERAGE-AIR® CORPORATION

3779 Champion Blvd. • Winston-Salem, NC 27105 USA • (336) 245-6400 • Fax (336) 245-6453 • (888) 845-9800 • www.beverage-air.com

Specifications are subject to change without prior notice. 12/16