



BEVERAGE-AIR

3779 Champion Blvd., Winston-Salem, NC 27105
1-888-845-9800 Fax# 1-336-245-6453
<http://www.Beverage-Air.com>

Item No. _____
Quantity _____

**BOTTOM MOUNTED
REACH-IN FREEZERS**
Vista Series
Solid Door

FB23-1S
FB27-1S
FB49-1S
FB72-1S

CUSTOMER'S CHOICE FOR A *HOT* KITCHEN
Tested & Certified to Ambient Class of 100°F

3 Year Parts/Labor Warranty Additional 2 Year Compressor Warranty

CABINET CONSTRUCTION

- Exterior—Stainless steel front & door, robust gray painted exterior sides
- Aluminum Interior
- Insulation—foamed-in-place CFC and HCFC-free polyurethane insulation.
- One-piece grille allows easy removal/installation for preventative maintenance.

MECHANICAL CONTROL

REFRIGERATION SYSTEM

- Bottom mount balanced refrigeration system for better ergonomics.
- Automatic condensate evaporation system for energy efficiency.
- Expansion Valve Technology
- Forced-air system ensures uniform distribution of airflow throughout the entire cabinet to ensure even product temperatures. Freezers maintain product temperatures to 0°F
- Self-contained refrigeration system uses environmentally friendly (CFC and HCFC-free) R404A refrigerant.
- Defrost system is automatic, time-initiated and temperature terminated operation.

DOORS

- Solid door configuration
- Anti-microbial door handles and door locks are standard.
- Spring-loaded hinges standard. Positive seal self-closing door(s) with 120° stay open feature.
- Plug-in magnetic door gaskets of one piece construction, removable without tools for ease of cleaning.

SHELVING

- Three (3) heavy duty epoxy coated wire shelves per section standard. Four (4) shelf clips included per shelf (field installed).
- Shelves are adjustable in 1/2" increments.

MODEL FEATURES

- LED interior lighting
- 6" heavy-duty casters included, two with brakes standard. 3" casters or 6" legs optional.
- Pre-wired plug for 115/60/1 phase.
- Epoxy coated evaporator prevents corrosion.



FB23-1S

Available From:



*Note: Not all markings may apply to all model variations.

Model Specified _____	Store# _____
Location _____	Quantity _____



BEVERAGE-AIR

Vista Series Bottom Mount Freezers

Models: FB23-1S, FB27-1S, FB49-1S, FB72-1S

MODEL	FB23-1S	FB27-1S	FB49-1S	FB72-1S
EXTERNAL DIMENSIONAL DATA				
Length Overall (inches) Length Overall (mm)	27 1/4" 692	30" 762	52" 1321	75" 1905
Depth Overall (inches) - <i>includes handle</i> Depth Overall (mm) - <i>includes handle</i>	33 3/4" 857	33 3/4" 857	33 3/4" 857	33 3/4" 857
Height Overall— (inches) / (mm) <i>Add 6" for legs or casters</i>	78" / 1981	78" / 1981	78" / 1981	78" / 1981
Number of doors	1	1	2	3
Depth with Door Open 90 °	60"	60"	60"	60"
INTERNAL DIMENSIONAL DATA				
NET Capacity (cubic ft.) NET Capacity (Liters)	23 651	27 765	49 1388	72 2039
Internal Length Overall (inches) Internal Length Overall (mm)	24" 610	27" 686	49" 1245	72" 1829
Internal Depth Overall (inches) Internal Depth Overall (mm)	28 1/2" 724	28 1/2" 724	28 1/2" 724	28 1/2" 724
Internal Height Overall—(inches) Internal Height Overall—(mm)	61 3/4" 1569	61 3/4" 1569	61 3/4" 1569	61 3/4" 1569
Number of shelves	3	3	6	9
ELECTRICAL DATA				
Full Load Amperes 115/60/1	10.9 A	11.9 A	11.9 A	11.9 A
REFRIGERATION DATA				
Horsepower	1/2	3/4	3/4	3/4
WEIGHT DATA				
Gross Weight (Crated lbs) Solid / Glass	408 / 325	373 / 400	583 / 560	725
Gross Weight (Crated kg) Solid / Glass	135 / 147	169 / 181	264 / 254	328

PLAN VIEWS

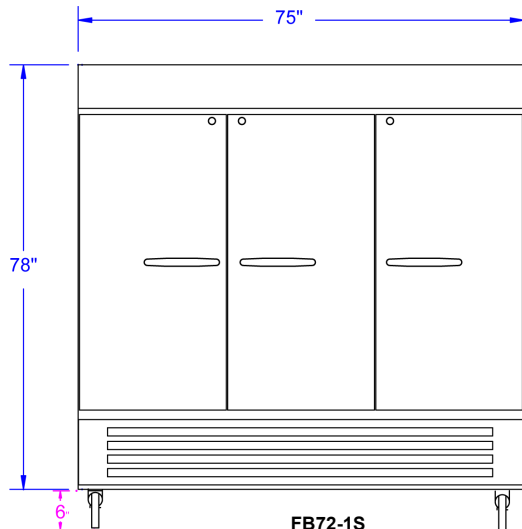
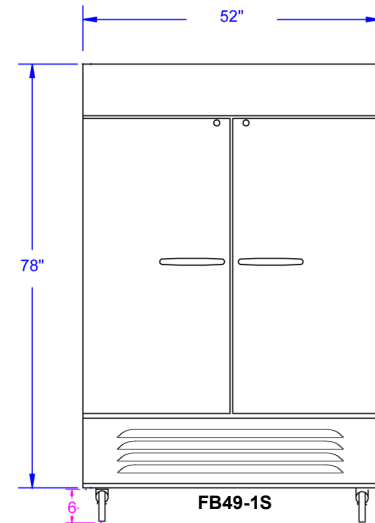
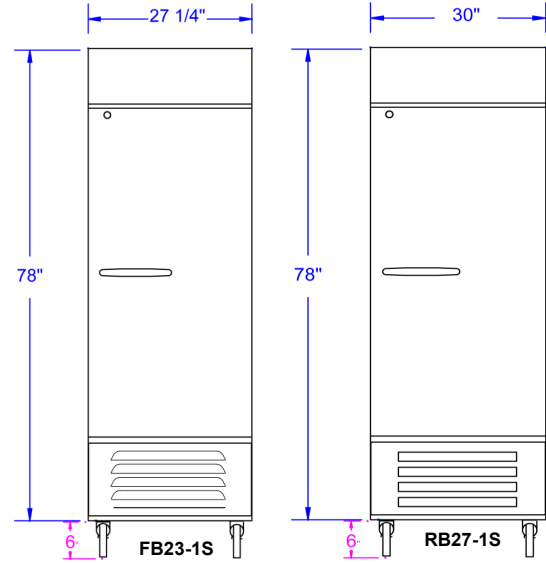

*Note: Freezers powered by 115/208-230 volts are designed for field wiring (requires 4-wire electrical circuit, hard-wired).

Note: Not all markings may apply to all model variations

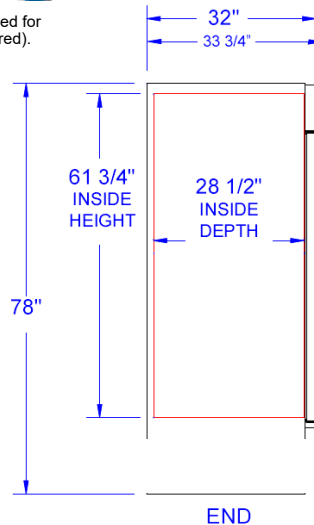

BEVERAGE-AIR® CORPORATION

3779 Champion Blvd. • Winston-Salem, NC 27105 USA • (336) 245-6400 • Fax (336) 245-6453 • (888) 845-9800 • www.beverage-air.com

Specifications are subject to change without prior notice. 10/17