



BEVERAGE-AIR

Project: _____	AIA#
Item: _____	
Location: _____	SIS#
Approved: _____	

HFPS HORIZON TOP MOUNT REACH-IN

MODELS:
HFPS2-1HG

HFPS2 Half-Glass Door Top Mount Reach-In Freezer



HFPS2-1HG

3 Year Parts/Labor Warranty
Additional 2 Year Compressor Warranty

CABINET CONSTRUCTION

- Stainless steel exterior and interior
- Full electronic control with One-touch defrost
- Expansion valve technology
- One piece grille
- LED interior light
- Self-closing doors with 120° stay-open feature, on cam-lift hinges
- Field reversible doors are easily removed for service and cleaning
- Magnetic gasket attached to each door for positive seal
- Anti-microbial door handles
- Three (3) heavy duty epoxy coated wire shelves per section
- 6" Heavy-duty casters, two (2) with brakes
- Maintains product temperatures of 0° F and below

OPTIONS & ACCESSORIES

- Tray slide pair, 1 tray slide set for (1) 18" x 26" or (2) 14" x 18" pans (A)
- Stainless steel universal tray slide pair, 1 tray slide set for (1) 18" x 26" or (2) 14" x 18" pans (AC)
- Epoxy coated wire rod tray slide (Kit #4)
- Epoxy shelves
- Shelf clips
- Door locks
- Stainless steel breaker
- 6" Legs
- 3" Casters
- Remote option

REFRIGERATION SYSTEM

- Refrigeration system uses R404a refrigerant
- Automatic, electric defrost
- Epoxy coated evaporator coil

HFPS2 Top Mount Reach-In: Horizon Series



3779 Champion Blvd., Winston-Salem, NC 27105
 1-888-845-9800 Fax: 1-336-245-6453
 Beverage-Air.com sales@bevair.com



BEVERAGE-AIR

MODEL	HFPS2-1HG
EXTERNAL DIMENSIONAL DATA	
Width Overall	52"
Depth Overall with Handle	33 5/8"
Height Overall with 6" Casters	84 1/2"
Number of Doors	4
Depth with Door Open 90 °	55 1/8"
Door Opening (in)	21 5/8" x 29 5/8" (4)
INTERNAL DIMENSIONAL DATA	
NET Capacity (cubic ft.)	45.6
Internal Width Overall (in)	48"
Internal Depth Overall (in)	26"
Internal Height Overall (in)	62"
Number of Shelves	6
ELECTRICAL DATA	
Full Load Amperes 115/60/1	16.0
REFRIGERATION DATA	
Horsepower	3/4
WEIGHT DATA	
Gross Weight	604 lbs
Height - Crated	87 1/2"
Width - Crated	55"
Depth - Crated	35"

Top Mount Reach-In Freezer

Model: HFPS2-1HG

Model Views

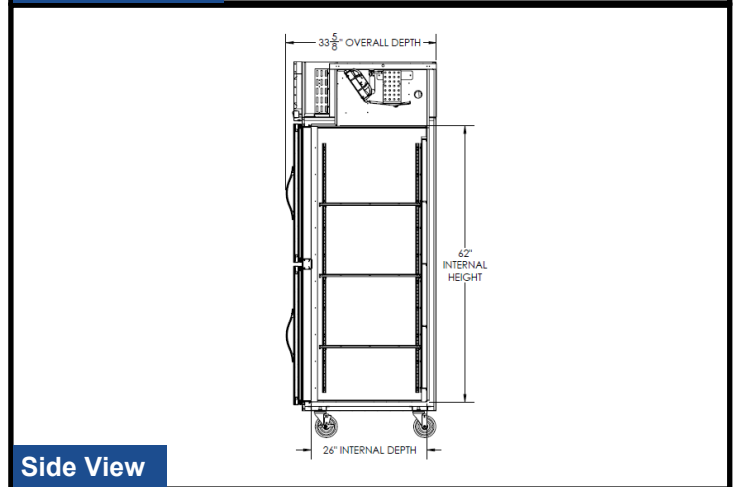
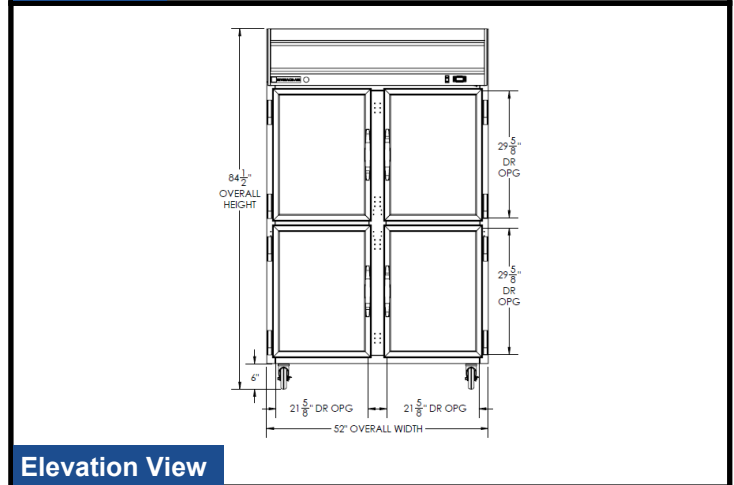
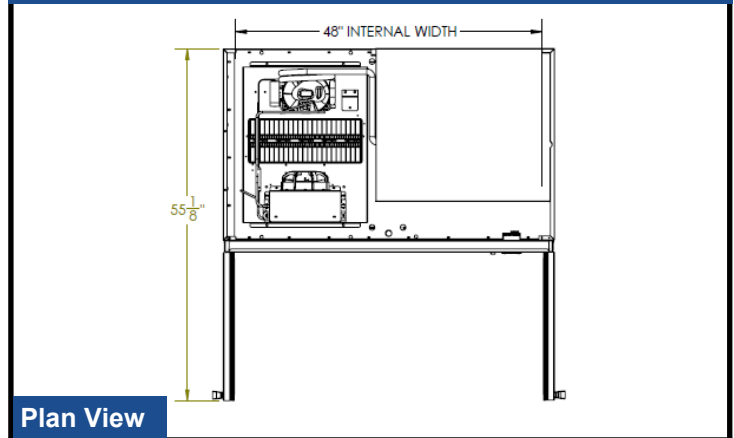

ELECTRICAL CONNECTION



115/60/1
NEMA-5-15P

Units pre-wired at factory and include 8' long cord and plug set.



an Ali Group Company



The Spirit of Excellence

3779 Champion Blvd., Winston-Salem, NC 27105
1-888-845-9800 Fax: 1-336-245-6453
Beverage-Air.com sales@bevair.com