



BEVERAGE-AIR

Project: _____

AIA#

Item: _____

Location: _____

SIS#

Approved: _____

HFPS HORIZON TOP MOUNT REACH-IN

MODELS:
HFPS3-5HS

HFPS3 Solid Half Doors Top Mount Reach-In Freezer

3 Year Parts/Labor Warranty
Additional 2 Year Compressor Warranty

CABINET CONSTRUCTION



HFPS3-5HS

- Stainless steel exterior and interior
- Interior liner is made of corrosion resistant aluminum
- Full electronic control with One-touch defrost
- Expansion valve technology
- One piece grille
- LED interior light
- Self-closing door with 120° stay-open feature, on cam-lift hinges
- Field reversible doors are easily removed for service and cleaning
- Magnetic gasket attached to each door for positive seal
- Door locks (solid doors only)
- Anti-microbial door handles
- Three (3) heavy duty epoxy coated wire shelves per section
- 6" Heavy-duty casters, two (2) with brakes
- Maintains product temperatures of 0° F and below

OPTIONS & ACCESSORIES

- Tray slide pair, 1 tray slide set for (1) 18" x 26" or (2) 14" x 18" pans (A)
- Stainless steel universal tray slide pair, 1 tray slide set for (1) 18" x 26" or (2) 14" x 18" pans (AC)
- Epoxy coated wire rod tray slide (Kit #4)
- Epoxy shelves
- Shelf clips
- Stainless steel breaker
- 6" Legs
- 3" Casters
- Remote option

REFRIGERATION SYSTEM

- Refrigeration system uses R404a refrigerant
- Automatic, electric defrost
- Epoxy coated evaporator coil

HFPS3 Top Mount Reach-In: Horizon Series



3779 Champion Blvd., Winston-Salem, NC 27105
1-888-845-9800 Fax: 1-336-245-6453
Beverage-Air.com sales@bevair.com



BEVERAGE-AIR

MODEL	HFP3S-5HS
EXTERNAL DIMENSIONAL DATA	
Width Overall	78"
Depth Overall with Handle	33 5/8"
Height Overall with 6" Casters	84 1/2"
Number of Doors	6
Depth with Door Open 90°	55 1/8"
Door Opening (in)	21 5/8" x 29 5/8" (6)
Shelf Area (sq. in)	552 1/2"
INTERNAL DIMENSIONAL DATA	
NET Capacity (cubic ft.)	72
Internal Width Overall (in)	74"
Internal Depth Overall (in)	26"
Internal Height Overall (in)	62"
Number of Shelves	9
ELECTRICAL DATA	
Full Load Amperes 208-230	16.0
REFRIGERATION DATA	
Horsepower	1.5
WEIGHT DATA	
Gross Weight (kgs)	971 lbs
Height - Crated	87 1/2"
Width - Crated	81"
Depth - Crated	36"

Note: Freezers powered by 208/230 volts are designed for field wiring (requires 4-wire electrical circuit, hard-wired).

Top Mount Reach-In Freezer

Model: HFP3S-5HS

Model Views

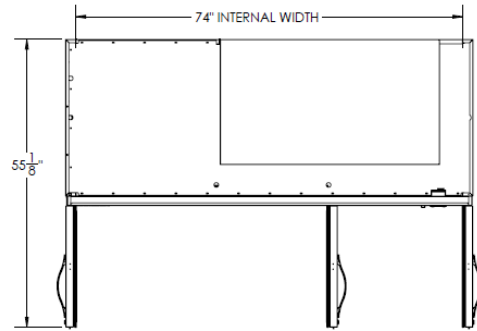

Plan View

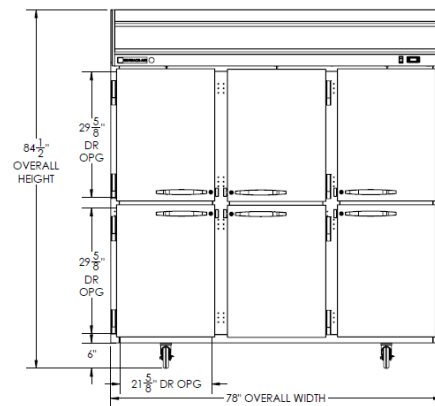

Elevation View

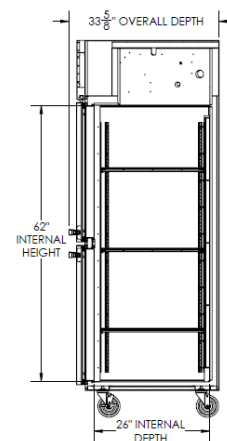

Side View



an Ali Group Company



3779 Champion Blvd., Winston-Salem, NC 27105
 1-888-845-9800 Fax: 1-336-245-6453
 Beverage-Air.com sales@bevair.com