



Project: _____	AIA#
Item: _____	SIS#
Location: _____	
Approved: _____	

## HFS HORIZON TOP MOUNT REACH-IN

### HFS2 Glass Door Top Mount Reach-In Freezer

**MODELS:**  
HFS2-1G



HFS2-1G

**3 Year Parts/Labor Warranty**  
**Additional 2 Year Compressor Warranty**

#### CABINET CONSTRUCTION

- Exterior is stainless steel front and gray painted sides
- Interior is stainless steel
- Full electronic control with One-touch defrost
- Expansion valve technology
- One piece grille
- LED interior light
- Self-closing door with 120° stay-open feature, on cam-lift hinges
- Field reversible doors are easily removed for service and cleaning
- Magnetic gasket attached to each door for positive seal
- Anti-microbial door handles
- Three (3) heavy duty epoxy coated wire shelves per section
- 6" Heavy-duty casters, two (2) with brakes
- Maintains product temperatures of 0° F and below

#### OPTIONS & ACCESSORIES

- Tray slide pair, 1 tray slide set for (1) 18" x 26" or (2) 14" x 18" pans (A)
- Stainless steel universal tray slide pair, 1 tray slide set for (1) 18" x 26" or (2) 14" x 18" pans (AC)
- Epoxy coated wire rod tray slide (Kit #4)
- Epoxy shelves
- Shelf clips
- Door locks
- Stainless steel breaker
- 6" Legs
- 3" Casters
- Remote option

#### REFRIGERATION SYSTEM

- Refrigeration system uses R404a refrigerant
- Automatic, electric defrost
- Epoxy coated evaporator coil

HFS2 Top Mount Reach-In: Horizon Series



3779 Champion Blvd., Winston-Salem, NC 27105  
 1-888-845-9800 Fax: 1-336-245-6453  
 Beverage-Air.com sales@bevair.com



# BEVERAGE-AIR

MODEL	HFS2-1G
<b>EXTERNAL DIMENSIONAL DATA</b>	
Width Overall	52"
Depth Overall with Handle	33 5/8"
Height Overall with 6" Casters	84 1/2"
Number of Doors	2
Depth with Door Open 90 °	55 1/8"
Door Opening (in)	21 5/8" x 61 3/4"
<b>INTERNAL DIMENSIONAL DATA</b>	
NET Capacity (cubic ft.)	45.6
Internal Width Overall (in)	48"
Internal Depth Overall (in)	26"
Internal Height Overall (in)	62"
Number of Shelves	6
<b>ELECTRICAL DATA</b>	
Full Load Amperes 115/60/1	16.0
<b>REFRIGERATION DATA</b>	
Horsepower	1.5
<b>WEIGHT DATA</b>	
Gross Weight	532 lbs
Height - Crated	87 1/2"
Width - Crated	55"
Depth - Crated	35"

## Top Mount Reach-In Freezer

Model: HFS2-1G

### Model Views

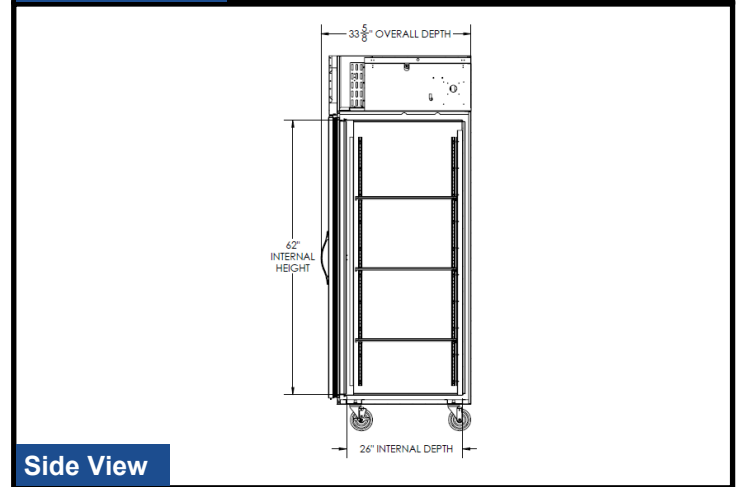
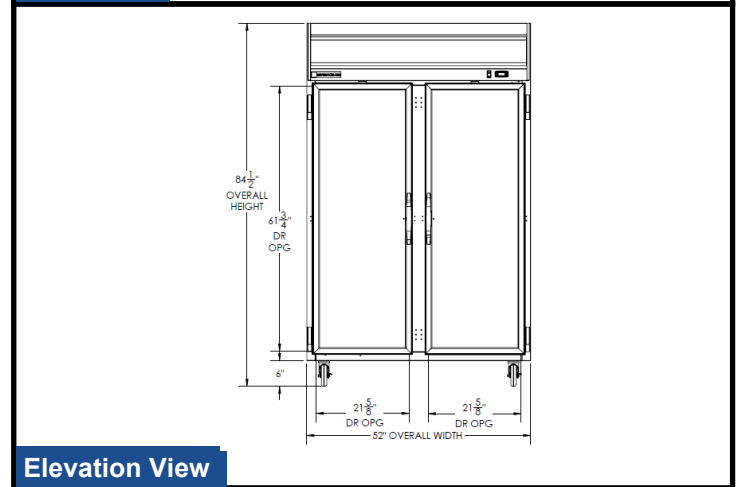
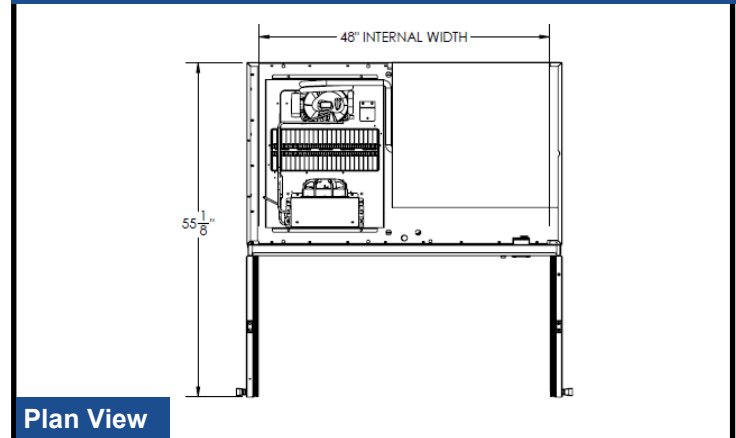

### ELECTRICAL CONNECTION



115/60/1  
NEMA-5-15P

Units pre-wired at factory and include 8' long cord and plug set.



an Ali Group Company



The Spirit of Excellence

3779 Champion Blvd., Winston-Salem, NC 27105  
1-888-845-9800 Fax: 1-336-245-6453  
Beverage-Air.com sales@bevair.com