



# BEVERAGE-AIR

3779 Champion Blvd., Winston-Salem, NC 27105  
1-888-845-9800 Fax# 1-336-245-6453  
http://www.Beverage-Air.com

## Commercial Refrigeration Equipment General Specification

### 3 Year Parts/Labor Warranty Additional 2 Year Compressor Warranty

#### WTRF SERIES WORKTOP UNITS

Versatile, compact (29" deep) models with stainless steel work tops and refrigerated/frozen storage of food products. **Refrigerator** and **Freezer** functions located within the same cabinet. Working height is 35 1/2."

#### CABINET CONSTRUCTION

Heavy duty construction includes stainless steel on front, sides, doors and grille. Stainless steel 2 1/2" thick worktop with 4" high removable backplash. Cabinet back and bottom are galvanized steel. Interior liner is made of aluminum for longer lasting corrosion protection. Interior thermometer is standard.

Cabinets are insulated with foamed-in-place polyurethane insulation of 2" minimum thickness. Field-reversible doors are mounted to cabinet on self-closing, cartridge style hinges with 120° stay open feature. **Freezer** section door openings include low wattage, anti-condensate heaters. A plug-in type vinyl magnetic gasket is attached to each door for positive seal. Convenient, contoured, pull handle is made of black anodized aluminum. Interior arrangement includes 2 steel wire epoxy coated shelves behind each door, adjustable in 1/2 inch increments.

#### REFRIGERATION

##### Refrigerator

Forced-air refrigeration system utilizes R134a refrigerant metered by a capillary tube system. Automatic (non-electric) condensate evaporator is standard. Interior forced air system, with high humidity evaporator coils, provides the ideal environment for food preservation.

##### Freezer

Forced air refrigeration system use capillary tube to meter refrigerant. Temperatures are held at 0°F and below. Refrigerant used is R404A. Automatic defrost is standard. Automatic (non-electric) condensate evaporator is provided.

#### ELECTRICAL

Units wired at factory and ready for connection to a 115/60/1 phase, 15 amp dedicated outlet. 8' long cord and plug set included.

Item No. \_\_\_\_\_  
Quantity \_\_\_\_\_

## WORK TOP DUAL-TEMP REFRIGERATOR/FREEZER 29" BASE MODEL SERIES

MODELS:  
WTRF50A  
WTRF52A



WTRF50A



WTRF52A

#### SPECIAL FEATURES

- Flexible door configurations (see page 2)
- Field-reversible doors
- Cartridge style door hinges provides positive seal & eliminates door sagging issues (excludes some special units).
- 6" casters, two with brakes standard.
- Optional 6" legs or 3" casters available (ADA)

#### ELECTRICAL CONNECTION

Units pre-wired at factory and include 8' long cord and plug set.



\*Note: Not all markings may apply to all model variations.

\*Note: Overall heights of casters may vary with different types of casters depending upon caster manufacturer designations.

Available From:

<b>Model Specified</b> _____	<b>Store#</b> _____
<b>Location</b> _____	<b>Quantity</b> _____



## BEVERAGE-AIR

### Standard Worktop Dual-Temp Refrigerator/Freezer Cabinets Models: WTRF50A, WTRF52A

MODEL	WTRF50A	WTRF52A
<b>EXTERNAL DIMENSIONAL DATA</b>		
Length Overall (inches)	50"	52"
Length Overall (mm)	1270	1321
Depth Overall (inches) - Less handle	29 1/4"	29 1/4"
Depth Overall (mm) - Less handle	743	743
Height Overall—on 6" casters (inches)*	39 1/2"	39 1/2"
Height Overall—on 6" casters (mm)*	1003	1003
Depth with Door Open 90°	52 1/4"	52 1/4"
Clear Door Opening (inches)	19 1/2" x 21 1/2"	19 1/2" x 21 1/2"
Number of doors	2	2
<b>INTERNAL DIMENSIONAL DATA</b>		
NET Capacity (cubic ft.)	14.6	15.0
NET Capacity (Liters)	413	425
Internal Length Overall (inches)	44"	46"
Internal Length Overall (mm)	1118	1168
Internal Depth Overall (inches)	20"	20"
Internal Depth Overall (mm)	508	508
Internal Height Overall (inches)	23"	23"
Internal Height Overall (mm)	584	584
Number of shelves	4	4
<b>ELECTRICAL DATA</b>		
Full Load Amperes 115/60/1 (Refrigerator section)	4.0	4.0
Full Load Amperes 115/60/1 (Freezer section)	6.0	6.0
<b>REFRIGERATION DATA</b>		
Horsepower (Refrigerator section)	1/6	1/6
Horsepower (Freezer section)	1/4	1/4
<b>WEIGHT DATA</b>		
Gross Weight (Crated lbs)	235	246
Gross Weight (Crated kg)	107	112

**\*Note:** Overall heights of casters may vary with different types of casters depending upon caster manufacturer designations.



### FLEXIBLE DOOR CONFIGURATIONS

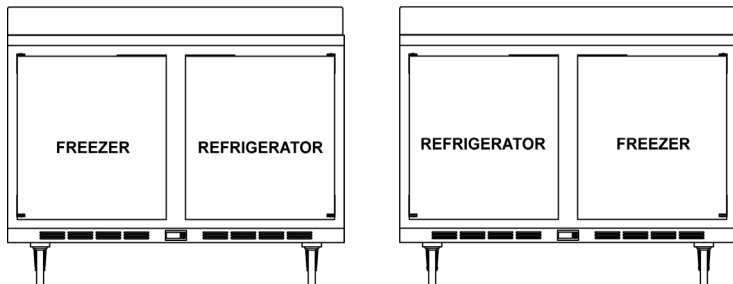

### PLAN VIEWS

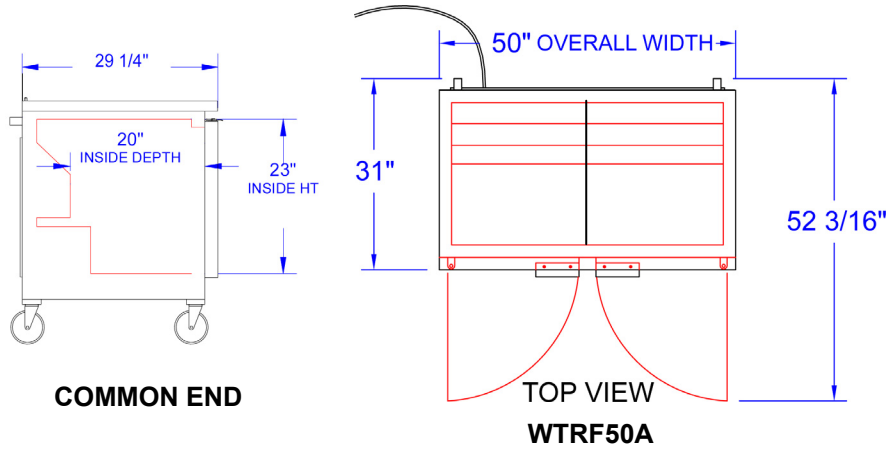

COMMON END

TOP VIEW  
WTRF50A

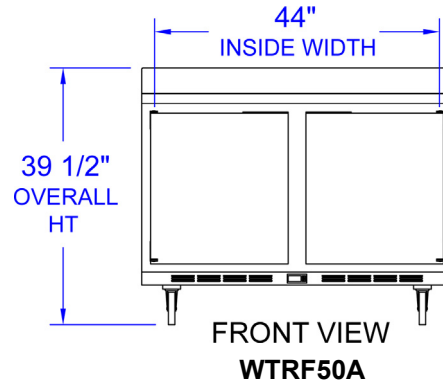

FRONT VIEW  
WTRF50A

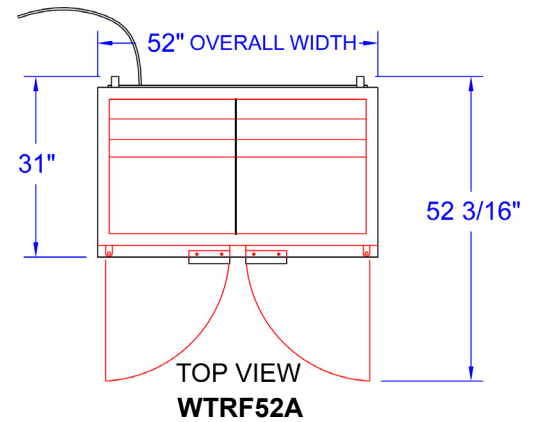

TOP VIEW  
WTRF52A

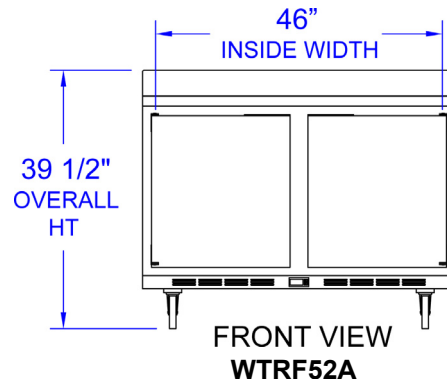

FRONT VIEW  
WTRF52A

## BEVERAGE-AIR® CORPORATION

3779 Champion Blvd. • Winston-Salem, NC 27105 USA • (336) 245-6400 • Fax (336) 245-6453 • (888) 845-9800 • www.beverage-air.com

Specifications are subject to change without prior notice. 06/13