

REMOTE CONDENSING BARREL FREEZER

Project _____ Date _____ Model **3341** Item# _____ Quantity _____



model 3341

Features

- Serve a variety of frozen smoothies, frozen cappuccinos or lattes, granitas, frozen fruit juices, frozen lemonades, cocktails or slushes.
- Works with remote condensing units up to 2 ½ hp per freezing cylinder.
- Draw customers and increase sales with the Flavorlight™ illuminating the frozen beverage, and high-impact backlit headers.
- This compact unit takes only 13" (33 cm) of counter space, and produces more than double the output capacity of visual freezers.
- Mix low indicator light enables users to refill product before it empties.
- Spring loaded dispense valve seals after dispensing. Ideal for self serve or busy clerk service.
- Heavy duty components, belt driven design and steel frame provide lasting commercial use.
- Reliable mechanical consistency control dispenses perfect product under all operating conditions.

Models & Dimensions

Remote Condensing Barrel Freezer

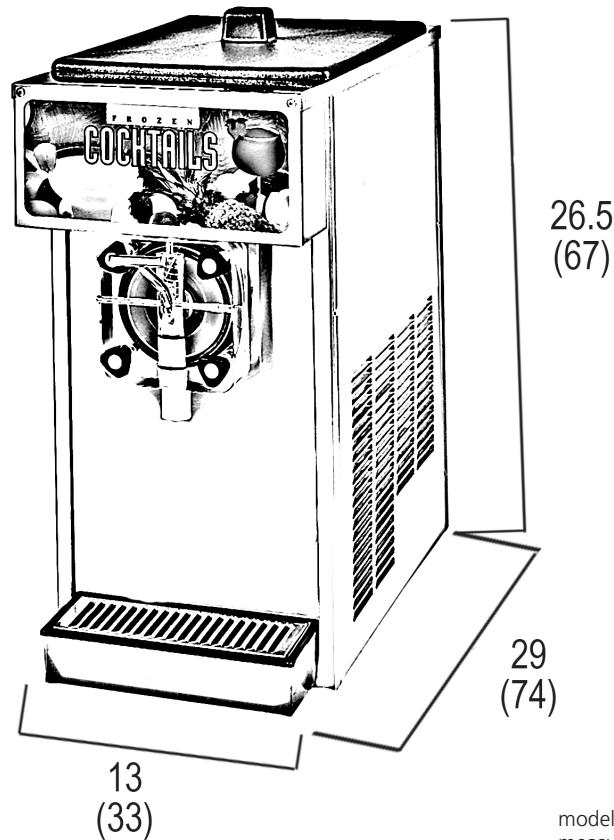

model 3341 represented
measurements in inches [cm]

Specifications

Model	Number of Barrels	Capacity	Compress	Drive Motor	Electrical	Product Dimensions (H x W X D)	Ship Dimensions (H x W X D)	Ship Weight
3341 (CFB3341-D)	1	Up to 30 gal. per hour* (113.6 L per hour) Frozen: 1.5 gal. (5.7 L) Storage: 5.0 gal. (18.9 L) Total: 6.5 gal. (24.6 L)	2.5 hp**	0.5 hp	120V / 60Hz 1 Ph / 816W 6.8 A	26.5" x 13" x 29" (67 cm x 33 cm x 74 cm)	30" x 19" x 38" (76 cm x 48 cm x 97 cm)	235 lbs (106.6 kg)

* Match condensing unit's size to output needs, up to 30 gallons (113.6 L) of frozen product per hour

** Works with remote condensing units up to 2.5 hp per freezing cylinder

Options

Front Mounted Spinner Kit (W0890053) - 110 V

4" (10 cm) Legs (W0890220)

