

**Bid Specifications:**

The Fried Food Holding Station shall be Merco model \_\_\_\_\_ rated at \_\_\_\_\_ watts, and \_\_\_\_\_ volts single phase AC.

# Fried Food Holding Station

## Fried Food Holding Station

### Models

#### Countertop Models

- FFHS-10  27019  
 FFHS-16  27007  27008  27012  
 FFHS-27  27000  27002

#### Drop-In Models

- 27018  
 27016  
 27017



### Standard Features

- Heavy-duty stainless steel construction.
- Removable product dividers, product tray and grease tray.
- Available in 10", 16" or 27" models.
- Therma-Lock™ Technology insures constant circulation of hot air over and through food to control moisture and maintain crispness.
- Longer hold times result in less waste, equaling increased profits.
- Internally controlled temperature and air flow are pre-set at optimum settings allowing simple on/off switch control.
- Unique ergonomic design allows the unit to be placed on any countertop or dropped-in to any work station as overhead heating elements are not required.

### Options & Accessories

- Additional Dividers  
 Fry Scoop Holder

### Specifications

**General:** Reduce waste and improve profits by extending the life of your fried foods. With its versatile divider system, the Merco Fried Food Holding Station can keep a variety of fried products at their peak serving temperature. Internally controlled air temperature of 230°F is directed over and through fried foods using Therma-Lock™ technology to maintain optimum product temperature and crispness, extending product retention up to three times!

**Construction:** The Merco Fried Food Holding Station features solid stainless steel construction for exceptional durability, aesthetics and cleanability. The product tray, grease tray, and product dividers are easily removable for fast clean up. Units

feature heavy-duty components and front centered on/off switch to provide durability to meet the demands of the commercial kitchen. Available in three sizes, in both countertop and drop-in models, the Merco Fried Food Holding Station is sure to meet any capacity requirements from early morning breakfast to midnight buffets.

**Simple Operation:** The air flow and internally controlled temperature of the Merco Fried Food Holding Station is factory pre-set for optimum holding time for all fried foods. No adjustment of air flow or temperature is required; countertop units are controlled by simple lighted on/off switch, drop-in units controlled by remote lighted on/off switch.

**Merco Guarantee:** Merco equipment is guaranteed to be free from quality problems in materials and workmanship for a period of one(1) year parts and labor from date of purchase, or eighteen (18) months from date of shipment from factory, whichever comes first.



### Models

- |         |                          |       |                   |
|---------|--------------------------|-------|-------------------|
| FFHS-10 | <input type="checkbox"/> | 27019 | Countertop Models |
| FFHS-16 | <input type="checkbox"/> | 27007 |                   |
| FFHS-27 | <input type="checkbox"/> | 27000 |                   |
|         | <input type="checkbox"/> | 27008 | Drop-In Models    |
|         | <input type="checkbox"/> | 27012 |                   |
|         | <input type="checkbox"/> | 27017 |                   |

1111 N. Hadley Rd.  
 P.O. Box 1229  
 Ft. Wayne, IN 46801-1229

Tel: 260.459.8200  
 Fax: 260.459.8240  
 Toll Free: 888.417.5462  
 E mail: info@mercosavory.com

www.mercosavory.com



Countertop Model

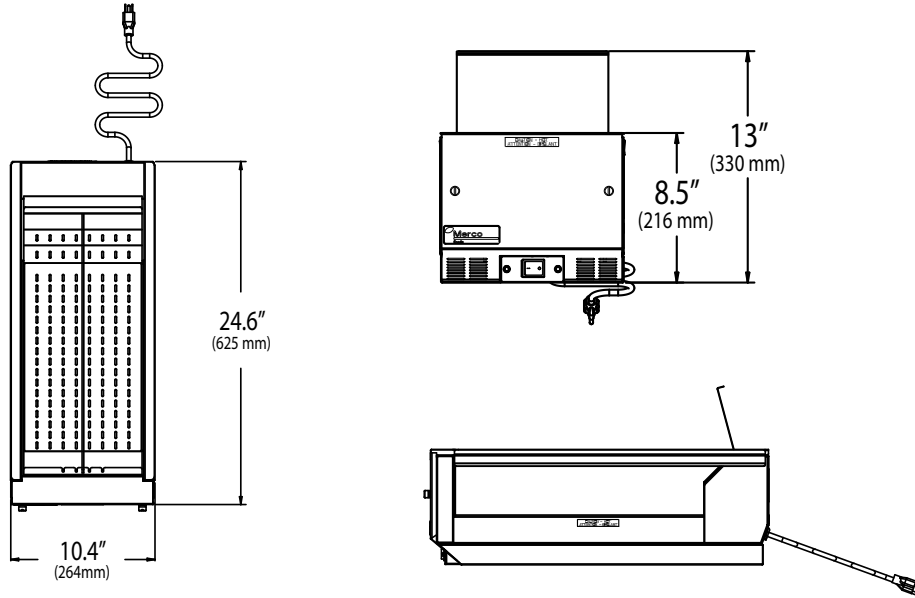

Drop-In Model

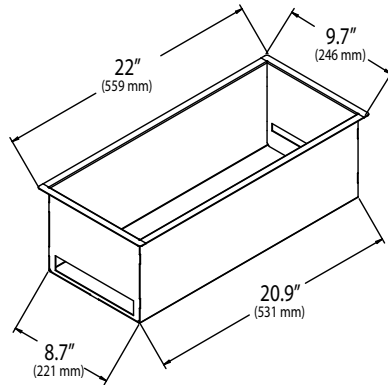

Counter Cutout Dimensions Should Be 8.875" (225 mm) x 21.06" (535 mm)

Fried Food Holding Station (FFHS-10) - Countertop Model

Part #	Model	Voltage	Amps	Watts	Hz	Phase	Cord Length	Plug Type	Width	Depth	Height
27019	FFHS-10	120	8.3	1000	60	1	5'	NEMA 5-15P	10.4" (264 mm)	24.6" (625 mm)	13" (330 mm)

Fried Food Holding Station (FFHS-10) - Drop-In Model

Part #	Model	Voltage	Amps	Watts	Hz	Phase	Cord Length	Plug Type	Width	Depth	Height
27018	FFHS-10	120	8.3	1000	60	1	5'	NEMA 5-15P	10.4" (264 mm)	24.6" (625 mm)	13" (330 mm)

Designs and specifications subject to change without notice.

# Fried Food Holding Station (FFHS-16)

## Countertop Models

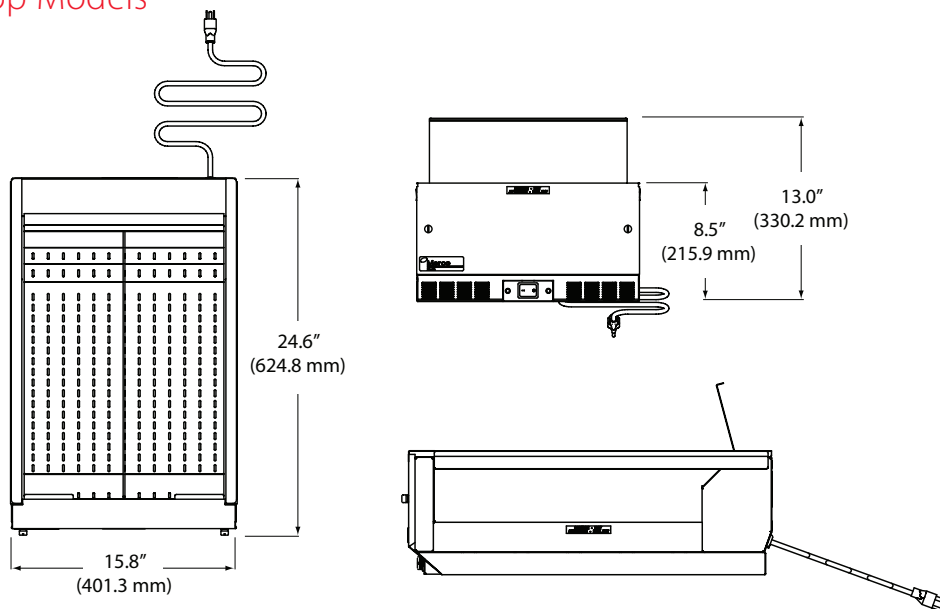

## Drop-In Model

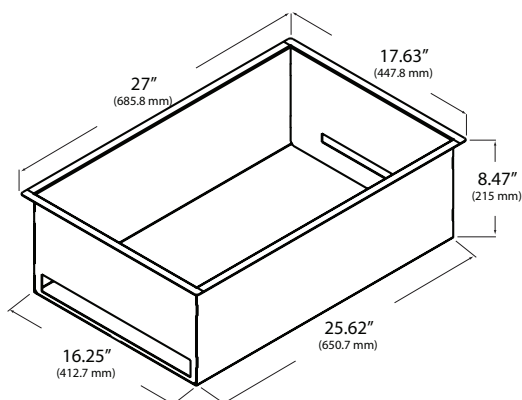

Counter Cutout Dimensions Should Be 16.375" (416 mm) x 25.75" (654 mm)

### Fried Food Holding Station (FFHS-16) - Countertop Models

Part #	Model	Voltage	Amps	Watts	Hz	Phase	Cord Length	Plug Type	Width	Depth	Height
27007	FFHS-16	120	12.0	1450	60	1	5'	NEMA 5-15P	15.8" (401 mm)	24.6" (625 mm)	13" (330 mm)
27008	FFHS-16 (CE)	230	7.5	1700	50	1	5'	CEE 7/7	15.8" (401 mm)	24.6" (625 mm)	13" (330 mm)
27012	FFHS-16	120	15.4	1850	60	1	5'	NEMA 5-20P	15.8" (401 mm)	24.6" (625 mm)	13" (330 mm)

### Fried Food Holding Station (FFHS-16) - Drop-In Model

Part #	Model	Voltage	Amps	Watts	Hz	Phase	Cord Length	Plug Type	Width	Depth	Height
27016	FFHS-16	120	15.4	1850	60	1	5'	NEMA 5-20P	15.8" (401 mm)	24.6" (625 mm)	13" (330 mm)

Designs and specifications subject to change without notice.



### Countertop Models

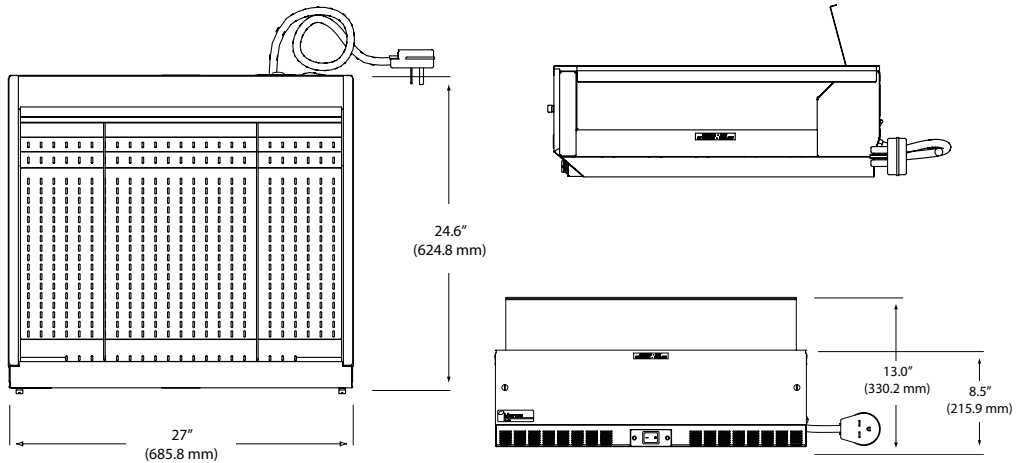

### Drop-In Model

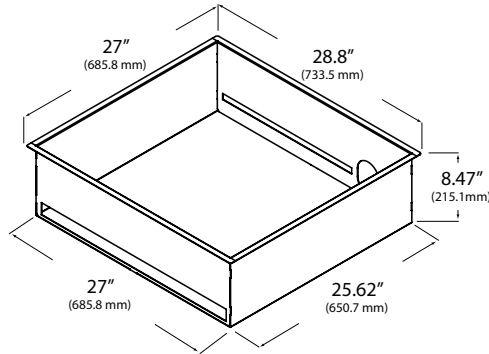

Counter Cutout Dimensions Should Be 27.125" (689 mm) x 25.75" (654 mm)

### Fried Food Holding Station (FFHS-27) - Countertop Models

Part #	Model	Voltage	Amps	Watts	Hz	Phase	Cord Length	Plug Type	Width	Depth	Height
27000	FFHS-27	208	21.6	4500	60	1	6'	NEMA L6-30P	27" (685.80 mm)	24.6" (624.8 mm)	13" (330.2 mm)
27002	FFHS-27	240	18.8	4500	60	1	6'	NEMA L6-30P	27" (685.80 mm)	24.6" (624.8 mm)	13" (330.2 mm)

### Fried Food Holding Station (FFHS-27) - Drop-In Model

Part #	Model	Voltage	Amps	Watts	Hz	Phase	Cord Length	Plug Type	Width	Depth	Height
27017	FFHS-27	208	18.8	4500	60	1	6'	NEMA L6-30P	27" (685.80 mm)	24.6" (624.8 mm)	13" (330.2 mm)

Designs and specifications subject to change without notice.

1111 N. Hadley Rd.  
P.O. Box 1229  
Ft. Wayne, IN 46801-1229

Tel: 260.459.8200  
Fax: 260.459.8240  
Toll Free: 888.417.5462  
E mail: info@mercosavory.com

www.mercosavory.com

