



Electrolux

EMPower Electric Bain Marie 16"

ITEM # _____

MODEL # _____

NAME # _____

SIS # _____

AIA # _____



EMPower

Electric Bain Marie 16"

169124 (ABE16)

EMPower Restaurant Range bain-marie, electric, 12,5 Amps, 16" wide with 4" adjustable, removable legs

Short Form Specification

Item No. _____

EMPower unit to be Electrolux Electric Bain Marie 16" (406 mm). Electric characteristics to be 120V one phase. EMPower unit for keeping cooked food at serving temperature by use of hot water inside the well. Water temperature to be controlled by thermostat with maximum temperature of 194 °F (90 °C). All major components can be accessed from the top and front of the appliance for ease of maintenance. Worktop and well in AISI 304 Stainless Steel. Front and side panels in Stainless Steel with Scotch Brite finish. Special heavy duty chrome plated knobs for durability and easy cleaning. The configuration of bezels and knobs provides high level of protection against water infiltrations. Right-angled side edges to allow flush fitting joints between EMPower units. Supplied with 4" (102mm) height adjustable, removable legs. EMPower unit may be installed on refrigerated base or open cupboard. In North America, products are covered by Electrolux Platinum

Star® Service Program two-year parts and one-year labor warranty, installation start-up and performance check-up after one year from installation.



APPROVAL: _____

Electrolux Professional, Inc.

www.electroluxusa.com/professional

10200 David Taylor Drive, Charlotte, NC 28262 • Telephone Number: 866-449-4200 • Fax Number: 704-547-7401



Electrolux

EMPower
Electric Bain Marie 16"



Main Features

- Bain Marie used for keeping cooked food at serving temperatures using hot water.
- Incoloy armored heating elements positioned beneath the base of the well.
- Water basin in AISI 304 Stainless Steel seamlessly welded to worktop of appliance. Basin has GN 1/1 dimensions, 150mm deep.
- Filling water level marked on later side of basin.
- Unit to feature manual refill of well.
- Water temperature controlled by thermostat with maximum temperature value of 90 °C.
- Basin drained by tap on the front of the machine.
- All major compartments located in front of unit for ease of maintenance.
- Worktop in AISI 304 Stainless Steel, 2mm thick.
- Front and side panels in Stainless Steel with Scotch Brite finish.
- Special heavy duty chrome plated knobs for durability and easy cleaning.
- The configuration of bezels and knobs provides high level of protection against water infiltrations.
- Right-angled side edges to allow flush fitting joints between units, eliminating gaps and possible dirt traps.
- Provided with kit for side-by-side connection between units for minimizing gaps and possible dirt traps.
- Supplied with 102 mm height adjustable, removable legs.
- Unit may be installed on refrigerated base by removing the legs and inserting the special pins (optional accessory model # 169048).
- Unit may be installed on open cupboard by removing the legs and inserting the screws provided as standard with the open cupboards.

Optional Accessories

- EMPower 4 pins kit for mounting unit to refrigerated/freezer. 1 kit is supplied with each EMPower refrigerated base PNC 169048
- EMPower back mounted rear shelf-spacer, PNC 169097
16"unit
- Portioning Shelf 12" PNC 169173
- Portioning Shelf 16" PNC 169174

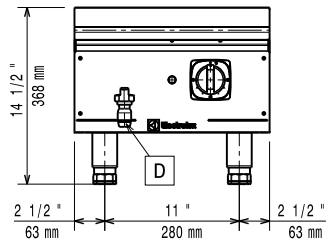
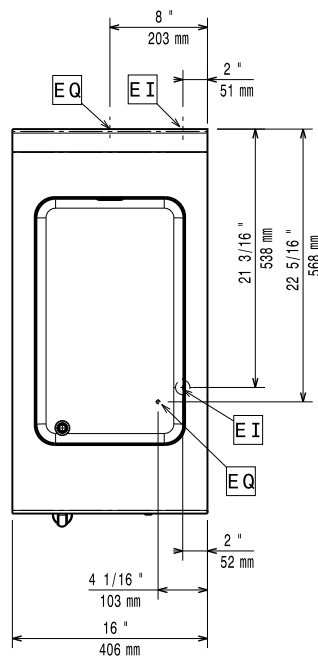
Front

Top

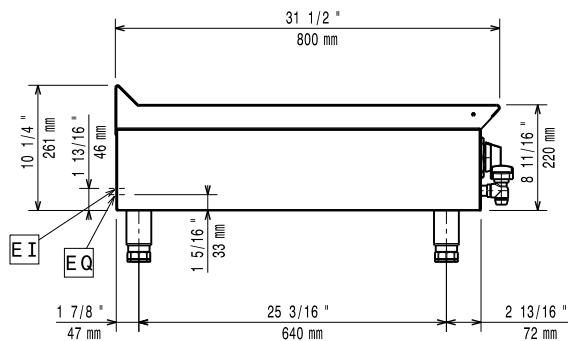
D = Drain
EI = Electrical connection
EQ = Equipotential screw

Side

Electric

Supply voltage:	169124 (ABE16)	120 V/1 ph/50/60 Hz
Amps:		12.5 A
Electrical power:		1.5 kW
Total Watts:		1.5 kW

Water:

Water Drain:	50 mm
---------------------	-------

Key Information:

Front Plates Power:	
External dimensions, Width:	16 " (406 mm)
External dimensions, Depth:	31 1/2" (800 mm)
External dimensions, Height:	14 5/8" (372 mm)
Net weight:	55 lbs (25 kg)
Shipping width:	18 1/2" (470 mm)
Shipping depth:	36 1/16" (916 mm)
Shipping height:	25 1/2" (648 mm)
Shipping weight:	66 lbs (30 kg)
Shipping volume:	9.85 ft ³ (0.28 m ³)