



Electrolux

air-o-convect air-o-convect Manual Boilerless Combi Oven 62 (electric)

ITEM # _____

MODEL # _____

NAME # _____

SIS # _____

AIA # _____



Electrolux

air-o-convect Manual Boilerless Combi Oven 62 (electric)

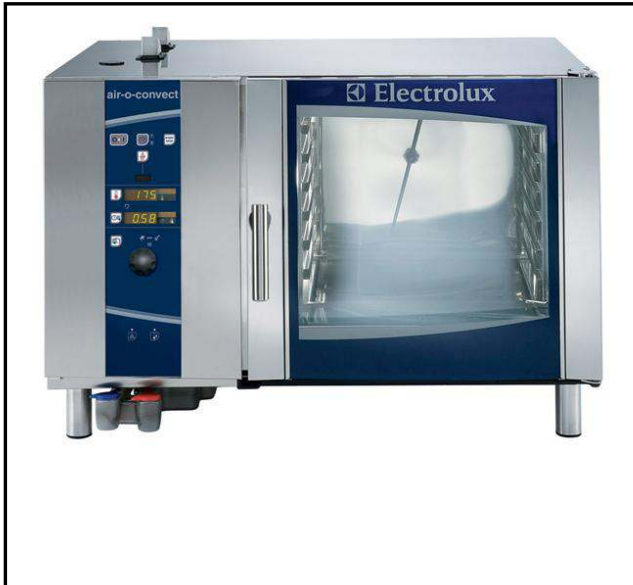

air-o-convect

air-o-convect Manual Boilerless Combi Oven
62 (electric)

269371 (AOS062ECM1)

EL.CONVECTION OVEN 6
GN2/I-208V-US

Short Form Specification

Item No. _____

Unit to be Electrolux air-o-convect Boilerless Combi Oven (electric). air-o-convect performs all of the functions of a convection oven and has a boilerless steaming capabilities to add and retain moisture for high quality, consistent cooking cycles. Cooking modes include a convection (hot air) cycle max 572°F (max 300°C) with an automatic moisture control function with 11 settings from zero to high moisture, double step cooking process, automatic pre-heating, a hold function and automatic rapid cooling. All 304 stainless steel construction, seamless hygienic cooking chamber with all rounded corners. Double thermo-glazed door with open frame construction for cool outside door panel. IPX5 (NEMA 4) spray water protection certification.

Covered by Electrolux Platinum Star® Service Program, two-year parts and one-year labor warranty, installation start-up and performance checkup after one year from installation.



APPROVAL: _____

Main Features

- Dry hot convection cycle max 572°F (max 300°C) ideal for low humidity cooking. Automatic moistener (11 settings) for boiler-less steam generation.
 - 0 = no additional moisture (browning, au gratin, baking, pre-cooked food)
 - 1-2 = low moisture (small portions of meat and fish)
 - 3-4 = medium low moisture (large pieces of meat, reheating, roasted chicken and proving)
 - 5-6 = medium moisture (roasted vegetable and first step of roasted meat & fish)
 - 7-8 = medium-high moisture (stewed vegetables)
 - 9-10 = high moisture (poached meat and jacket potatoes)
- Double step cooking to set two different phases.
- Exhaust valve electronically controlled to extract humidity in excess for extra crispy results.
- air-o-flow: fresh air from the outside is directed to the bi-functional fan, becomes pre-heated and then pushed into the cooking chamber to guarantee an even cooking process.
- Core temperature probe.
- Fan speeds: full, half speed and pulse. Full speed active as default. Half speed ideal for delicate cooking such as baking. Pulse ideal for low weight loss and for keeping food warm at the end of the cooking cycle.
- air-o-clean™ automatic and built-in self cleaning system (4 automatic and 1 semi-automatic cycles).
- Automatic and manual rapid cooling activation when going from a higher to a lower cavity temperature.
- Supplied with n.1 tray rack 1/1GN, 2 1/2" 65 mm pitch.
- Electrolux Platinum Star® Service package included:
 - 2-year parts, 1-year labor warranty
 - Start-up installation check
 - Equipment check-up after 12 months from installation.
- ETL safety approved, complies with UL 197 and CSA 22.2 listings.
- ETL sanitation approved, complies with NSF/ANSI 2 listing.
- Gas burner is certified by Gastec for high efficiency and low emissions.

Construction

- 304 AISI stainless steel construction throughout.
- Double thermo-glazed door with open frame construction, for cool outside door panel. Swing hinged easy-release inner glass on door for easy cleaning.
- IPX 5 spray water protection certification for easy cleaning.
- Seamless hygienic cooking chamber with all rounded corners for easy cleaning.
- Swing hinged front panel for easy service access to main components.

Electrolux Professional, Inc.

www.electroluxusa.com/professional

10200 David Taylor Drive, Charlotte, NC 28262 • Telephone Number: 866-449-4200 • Fax Number: 704-547-7401



Included Accessories

- 3 of Single 304 stainless steel full-size grid PNC 922076 (21"x26")

Optional Accessories

- - NOT TRANSLATED - PNC 920003
- Automatic water softener for ovens PNC 921305
- Resin sanitizer for water softener PNC 921306
- Caster kit for base for 61, 62, 101 and 102 oven bases PNC 922003
- (4) Adjustable feet for countertop models 61, 62, 101 & 102 ovens-adjustable height: 5-15/16" - 7-7/8" (150-200mm) PNC 922012
- Pair of half size oven racks, type 304 stainless steel PNC 922017
- Tray support, for 61 and 101 oven bases PNC 922021
- Chicken Racks, pair (2) (fits 8 chickens per rack) PNC 922036
- Tray support, for 62 and 102 oven bases PNC 922041
- Trolley, for roll-in rack for 62 and 102 oven PNC 922042
- Slide-in rack support with handle for 62 and 102 oven PNC 922047
- Open base with rack guides for air-o-steam 102 PNC 922063
- Single 304 stainless steel full-size grid (21"x26") PNC 922076
- Kit to connect external rinse aid & detergent tank (61, 62, 101 and 102 ovens) PNC 922169
- External side spray unit PNC 922171
- Pair of 304 stainless steel full-size grids (21" x 26") PNC 922175
- Fat Filter, for 61 and 62 oven PNC 922177
- Open base with rack guides, for 62 and 102 oven PNC 922198
- Basket for detergent tank (wall mounted) for 201 and 202 oven PNC 922209
- Pair of frying baskets PNC 922239
- Control Panel Filter, for 62 and 102 oven PNC 922247
- Double-click closing catch for oven door PNC 922265
- Grid for whole chicken 1/1GN (8 per grid - 1,2kg each) PNC 922266
- Stacking kit: 62 on 62 or 62 on 102 electric oven PNC 922267
- 6 rack cassette for 62 oven (standard pitch) PNC 922269
- Trolley for rack cassette for 62 PNC 922270
- Heat Shield, for 62 oven PNC 922271
- Electronic Board for HACCP through PC Network, for air-o-steam and air-o-convect Ovens PNC 922275
- Kit flaged feet PNC 922320
- Kit Universal Skewer Rack & (6) long skewer ovens (TANDOOR) PNC 922325
- Universal Skewer pan for ovens (TANDOOR) PNC 922326
- Skewers for ovens, (6) 14" short (TANDOOR) PNC 922328
- Fat collection tray for ovens (1.5") PNC 922329
- (NPT) Adaptor, 1-1/4 gas for ovens PNC 922332
- Riser on feet for stacked ovens 62 on 62 PNC 922334
- Riser on casters for stacked ovens 62 on 62 PNC 922335
- Casters for stacked ovens 62 on 62 and 62 on 102 PNC 922336

- Smoker for ovens PNC 922338
- Kit check valve PNC 922347
- Multipurpose hook PNC 922348
- NON-STICK UNIVERSAL PAN 12"X20"X3/4" PNC 925000
- NON-STICK UNIVERSAL PAN 12"X20"X1 1/2" PNC 925001
- NON-STICK UNIVERSAL PAN 12"X20"X2 1/2" PNC 925002
- 6 NON-STICK U-PAN 12"X20"X3/4" PNC 925012
- 6 NON-STICK U-PAN 12"X20"X1 1/2" PNC 925013
- 6 NON-STICK U-PAN 12"X20"X2 1/2" PNC 925014

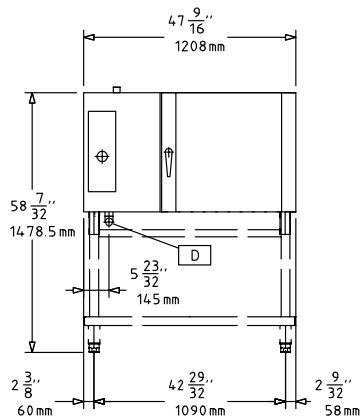
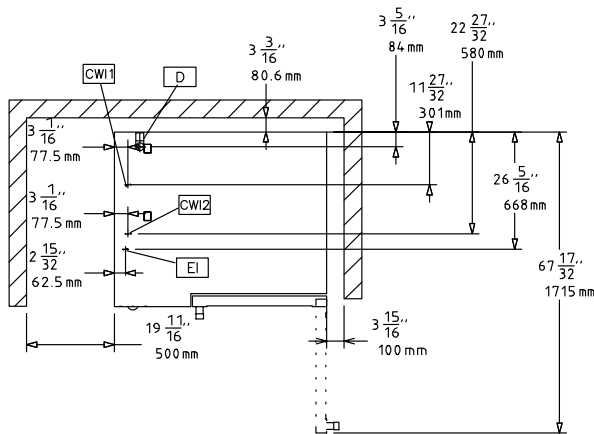
Front

Top

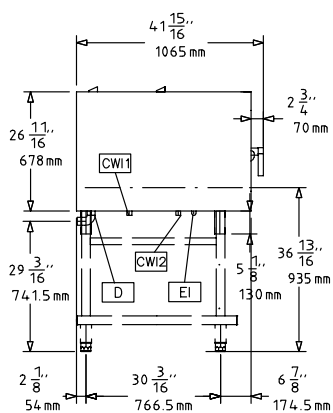
- CWI** = Cold Water inlet
D = Drain
EI = Electrical connection
EQ = Equipotential screw

Side

Electric

Supply voltage:
269371 (AOS062ECM1) 208 V/3 ph/60 Hz
Amps: 58 A
 Circuit breaker required
Total Watts: 21 kW

Water:

Water inlet "CW" connection: 3/4"
Water consumption (gal./hr.): Min: 0.09 Max: 2.77
Total hardness: 5-50 ppm
Pressure: 22-65 psi (1.5-4.5 bar)
Drain "D": 1"1/4 NPT

Electrolux recommends the use of treated water, based on testing of specific water conditions.

Please refer to user manual for detailed water quality information.

Incoming Cold/hot Water line size: 3/4"
Drain line size: 1"1/4 NPT
Water cold/hot pipe size: 3/4"

Installation:

Clearance: 2" (5 cm) rear and right hand sides
Suggested clearance for service access: 20" (50 cm) left hand side

Capacity:

Sheet pans: 6 - 18"x 26"
Steam pans: 12 - 12"x 20"
Half size sheet pans: 12 - 13"x 18"
Max load capacity: 106 lbs. (48 kg)

Key Information:

External dimensions, Width: 47 9/16" (1208 mm)
External dimensions, Depth: 41 15/16" (1065 mm)
External dimensions, Height: 31 13/16" (808 mm)
Net weight: 313 lbs (142 kg)
Shipping width: 49 13/16" (1265 mm)
Shipping depth: 44 11/16" (1135 mm)
Shipping height: 41 15/16" (1065 mm)
Shipping weight: 406 lbs (184 kg)
Shipping volume: 53.99 ft³ (1.53 m³)
Automatic cleaning system X